

TM100TM

High Performance Industrial Thermal Mass Flow Meter



DATA SHEET



Need the Features, but Lack the Budget?

The TM100™ delivers amazing value to end users with burner and combustion applications, natural gas and pure gas monitoring, and compressed gas and packing leaks. Make no sacrifices in precision, speed, and field flexibility to maintain optimum process efficiency. Sierra's TM100 is built to last and meet your application, budget, and delivery needs.

Benefit from the powerful features of Sierra's TM500™ at a more affordable cost with the TM100. If your application doesn't require the TM500's remote configuration, AC power, or flow range over 25,000 sfpm, Sierra's TM100™ may be the ideal meter for you.

The TM100 makes you smarter and your processes more reliably efficient. And we're always here if you need us—Sierra's promise to customers for 50 years.

Why Thermal?

Sierra's thermal technology delivers direct measurement of gas mass flow. Unlike differential pressure (dP) meters that measure volumetric flow, it's simpler to make and maintain, and no temperature or pressure corrections are required. dP requires additional calculations to convert volumetric flow to mass flow, the measurement that most often needs to be reported. That reduces accuracy. Thermal has negligible pressure drop or flow restrictions, significantly reducing expense once the full ownership cost is considered.

Continued pg 4

Precision

- Accuracy
 - +/- 1.0% of reading plus +/- 0.2% of full-scale – Air, Nitrogen
 - +/- 1.5% of reading plus +/- 0.5% of full-scale – All other gases
- Repeatability +/- 0.2% of full scale
- Direct measurement of gas mass flow / No volume to mass calculations
- DigiSense™ robust sensor design
- Welded, 316 SS sensor
- Insertion and Inline styles
- Rotatable enclosure: allows +/-180 degree display orientation
- 12 to 24 volt DC power
- Flow Range: 0 to 25,000 sfpm
- Wide measurement range: up to 1000:1 turndown; 100:1 typical
- Negligible pressure drop
- One 4-20mA output for flow rate or temperature
- Measure gas flow rate in scfm, mcf/h, and more
- Low-end sensitivity (0-500 sfpm) for leak detection and other low-flow applications
- Communication options: HART with pulse output or Modbus RTU (RS485), BACnet MS/TP (RS485)
- FM/FMc, ATEX, IECEx approvals. CE mark.
- NEMA 4X

Field Flexibility

- Microprocessor based, field programmable electronics
- Menu of field selectable gas compositions with Gas-Mix™ (Optional)
- Free TM100-View™ software available / USB port connects to a PC
- Calibration Validation with TM-Cal™
- NIST-traceable calibration

Delivery

- 2 to 3 week lead times are typical after order acceptance
- 1 week or less expedited lead times are available after order acceptance
- Contact Sierra for details

DigiSense™ Sensor

DigiSense is the state-of-the-art sensor technology used in the TM100. Unlike other thermal flow sensors, it interfaces directly with its microprocessor for greater control, precision, and programmability. DigiSense accurately responds to changes in process variables (gas flow rate, pressure, and temperature) to determine mass flow rate, totalized flow, and temperature.

DigiSense's correlation algorithms allow the meter to be calibrated on a single gas in the factory while enabling the user to select other gases in the Gas-Mix menu.



Gas-Mix™ Menu

Gas-Mix allows users rapid gas selection or mixing in the field from a pre-calibrated list of 12 gases. With an onboard 2-line x 16-character backlit display, end users can view flow rate, total, elapsed time, process gas temperature, and alarms. TM100's display is also used with the configuration panel to access flow meter settings, such as 4-20mA and pulse output scaling, pipe diameter, low flow cutoff, flow filtering (damping), display options, and high or low alarm limits.

TM100-View™ Software

Sierra's TM100-View advanced software is a free PC-compatible application available for download from Sierra's website. Connect your Windows-based laptop or PC to the meter using the USB port interface to access data and configure the meter's settings.

TM100-View Features

- Get quick access to all configuration parameters with pop-up windows and pull-down menus
- View raw data to diagnose or troubleshoot your meter
- Select measurement units, flow and temperature ranges, alarm settings, and more
- Print or save a TM-Cal Calibration Validation Certificate
- Set alarms and display alarm codes
- Use simulation mode to align 4-20mA output with the input to the customer's PLC/DCS

TM-Cal™ Calibration Validation

The TM100 includes on-board calibration verification through the TM-Cal feature. This diagnostic is automated and does not require any additional equipment or removal of the TM100 from your process. TM-Cal takes less than five minutes for completion and can be initiated via the meter's display, Modbus RTU, or TM100-View software. When the test is complete, a pass/fail response indicates if the meter requires troubleshooting or recalibration.

Using TM100-View to run TM-Cal results in a calibration validation certificate that can be printed or saved for compliance with the user's local regulations and metrology requirements. The certificate includes all relevant information from the test – time and date, meter identification, and pass/fail results.

Measurably Different™

Our primary goal at Sierra is to help make your operation smarter and more productive with the precision flow measurement tools we design and build to meet your application, budget, and delivery needs. And with 50 years of expertise, we're always here for you.

Performance Specs

Flow Accuracy

Air and Nitrogen (N₂): +/-1% of reading +/-0.2% of full scale
 Other Gases: +/-1.5% of reading +/-0.5% of full scale
 Accuracy specification applies to customer's selected flow range
 Maximum range: 15 to 25,000 SFPM (0.07 to 120 NMPS)
 Minimum range: 15 to 500 SFPM (0.07 to 2.4 NMPS)

Straight, Unobstructed Pipe Requirement

- Insertion: 15 diameters upstream 10 downstream
- Inline: 8 diameters upstream, 4 downstream

Flow Repeatability

±0.2% of full scale

Flow Response Time

0.8 seconds (one time constant)

Temperature Accuracy

±1° F (±0.6° C)

Calibration

Factory Calibration to NIST-traceable standards

TM-Cal™

In-situ, operator-initiated calibration validation

Operation Specs

Gas Selections

Gas-Mix is an optional feature of the TM100. You can choose from menus of single gases or create custom gas mixtures if purchased.

Single (100%)	Mixes
Air	Air
Argon	Argon
Butane	Butane
Carbon Dioxide	Carbon Dioxide
Ethane	Ethane
Helium	Helium
Hydrogen	Hydrogen
Methane	Methane
Natural Gas	Nitrogen
Nitrogen	Oxygen
Oxygen	Propane
Propane	

Gas Pressure

Maximum gas pressure at 100°F
 Insertion: 740 psig (51 barg)
 316 SS inline w/NPT ends: 500 psig (34 barg)
 316 SS inline w/150lb flanges: 230 psig (16 barg)
 CS inline w/NPT ends: 500 psig (34 barg)
 CS inline w/150lb flanges: 285 psig (20 barg)
 Hot-Tap and Ball Valve: 150 psig (10 barg) max

Notes: Check with factory for higher pressure options.
 With Teflon Ferrule option, maximum gas pressure is 60 psig (4.1 barg) maximum.

Gas Pressure (continued)

Pressure ratings stated for temperature of 100°F (38°C).
 The EU Pressure Equipment Directive (PED) requires that the minimum ambient and fluid temperature rating for carbon steel flow bodies not be below -29°C.

Temperature

DigiSense™ Sensor: -40°C to 250°F (-40°C to 121°C)
 Enclosure: -40°C to 158°F (-40°C to 70°C)*

*NOTE: Display dims below -4°F (-20°C); function returns once temperature rises again.

Flow Velocity Range

15 to 25,000 sfpm (0.07 to 120 nm/s)
 Turndown: up to 1000:1; 100:1 typical

Maximum Flow Ranges for TM100 Insertion Flow Meters			
Pipe Diameter	SCFM	MSCFD	NM3/Hr
1.5" (40mm)	0-354	0-510	0-558
2" (50mm)	0-583	0-840	0-920
2.5" (63mm)	0-830	0-1,310	0-1,200
3" (80mm)	0-1,280	0-1,840	0-2,020
4" (100mm)	0-2,210	0-3,180	0-3,480
6" (150mm)	0-5,010	0-7,210	0-7,910
8" (200mm)	0-8,680	0-12,500	0-13,700
10" (250mm)	0-13,600	0-19,600	0-21,450
12" (300mm)	0-19,400	0-27,900	0-30,600

NOTE: To determine if the TM100 will operate accurately in other pipe sizes, divide the maximum flow rate by the pipe area. The application is acceptable if the resulting velocity is within the velocity range above.

Maximum Flow Ranges for TM100 Inline Flow Meters			
Size	SCFM	MSCFD	NM3/Hr
0.75"	0-93	0-134	0-146
1"	0-150	0-216	0-237
1.25"	0-260	0-374	0-410
1.5"	0-354	0-510	0-558
2"	0-583	0-840	0-920
2.5"	0-830	0-1,310	0-1,200
3"	0-1,280	0-1,840	0-2,020
4"	0-2,210	0-3,180	0-3,480
6"	0-2,500	0-3,600	0-3,950

NOTE: Standard conditions of air at 70°F and one atmosphere. Consult factory for other gases and for flow ranges above those listed. Inline meters above 2,500 SCFM (3,950 NM3/H) may require third-party calibration. Contact Sierra Instruments.

Operation Specs (continued)

Relative Humidity

90% RH maximum; non-condensing

Units of Measurement (field-selectable)

SCFM, SCFH, NM3/M, NM3/H, NM3/D, NLPS, NLPM, NLPH, MCFD, MSCFD, SCFD, MMSCFD, MMSCFM, SM3/D, SM3/H, SM3/M, LB/S, LB/M, LB/H, LB/D, KG/S, KG/M, KG/H, SLPM, MT/H

Input Power

12 to 24 VDC $\overline{\text{---}}$, 6 watts
Full input power range: 10 to 30 VDC.
20 Watt or greater power supply is recommended.

Outputs

Channel 1:

Standard isolated 4-20mA output for flow or temperature; fault indication per NAMUR NE43; HART communication option.

Channel 2:

Option of pulse output or Serial Communication:

- Isolated pulse output: 5 to 24VDC, 20mA max., 0 to 100Hz for flow (the pulse output can be used as an isolated solid state output for alarms).
- Modbus RTU (RS485)
- BACnet MS/TP (RS485)

USB Communication

USB for connecting to a laptop or computer is standard.
Free PC-based software tool - TM100-View™ - provides complete configuration, process monitoring, and data logging functions.

4-20mA and Loop Verification:

Simulation mode used to align 4-20mA output with the input and pulse output (if ordered) with the input to customer's PLC/DCS.

Physical Specs

Probe Diameter

Probe diameter 3/4-inch for insertion and inline flow meters.

Sensor Material

316 stainless steel

Enclosure

NEMA 4X (IP67), aluminum, 3/4-inch FNPT conduit entries

Software

Use Gas-Mix™, if purchased, for rapid gas selection or mixing in the field from a pre-calibrated list of 12 gases.

Use TM-Cal™ to validate meter functions

Use TM100-View™ to access all meter configuration & Data logging

Approvals

CE Mark

EMC Directive: 2014/30/EU
Electrical Equipment for Measurement, Control and Lab Use:
EN61326-1:2013
Pressure Equipment Directive: 2014/68/EU
Weld Testing: EN ISO 15614-1 and EN ISO 9606-1, ASME B31.3

FM (FM21US0123X) and FMc (FM21CA0089X)

Class I, Division 1, Groups B, C, D;
Class II, Division 1, Groups E, F, G;
Class III, Division 1; T4, Ta = -40° to 70°C;
Class I, Zone 1, AEx/Ex db IIB + H2 T4; Gb Ta = -40°C to 70°C; Type 4X, IP66/67

ATEX (FM23ATEX0041X)

II 2 G Ex db IIB + H2 T4; Gb Ta = -40°C to 70°C; IP66/67
II 2 D Ex tb IIIC T135°C; Db Ta = -40°C to 70°C; IP66/67

IECEX (IECEX FMG 23.0019X)

Ex d IIB + H2 T4; Gb Ta = -40°C to 70°C; IP66/67
Ex tb IIIC T135°C; Db Ta = -40°C to 70°C; IP66/67

ATEX and IECEX Standards

EN IEC 60079-0 IEC 60079-0
EN 60079-1 IEC 60079-1
EN 60079-31 IEC 60079-31
EN 60529 +A1 +A2 IEC 60529

Dimensions

TM100 Insertion Meter

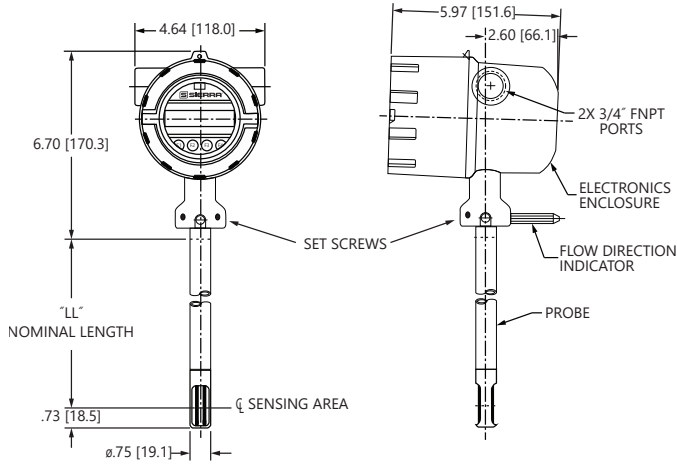

TM100 Inline Meter with Flow Body NPT End Connections

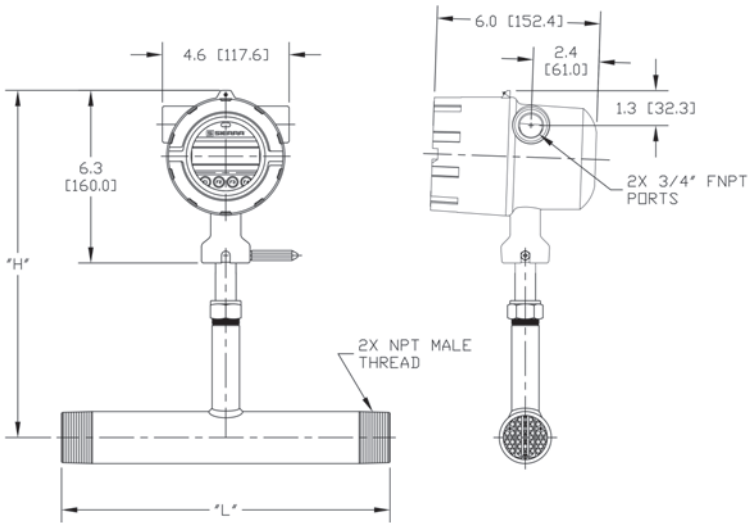

TM100 Inline Meter with Body 150 lb RF Flange End Connections

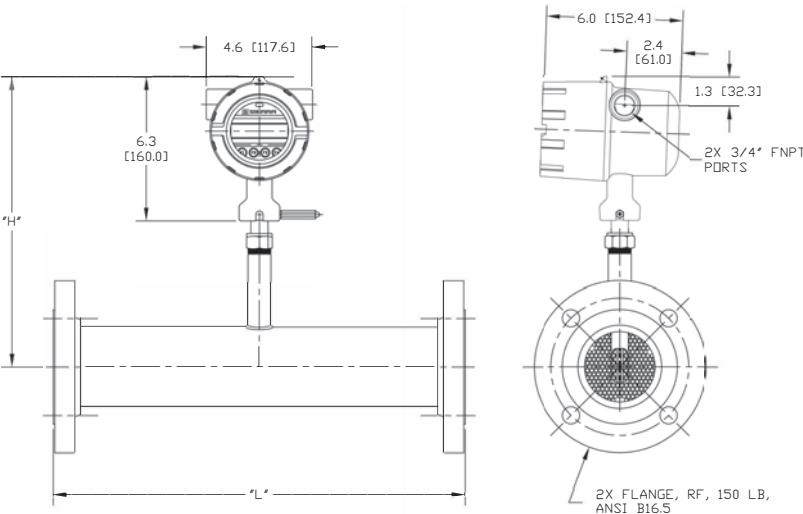

Insertion Styles

Standard Probe Lengths in Inches (mm)

6.0 (152.4)	18.0 (457.2)
9.0 (228.6)	24.0 (609.6)
12.0 (304.8)	30.0 (762.0)
15.0 (381.0)	36.0 (914.4)

Assuming there is no insulation or hot-tap, Sierra recommends the following probe lengths:

Pipe Size	Probe Length
1.5" (40mm) to 6" (150mm)	6-inch
8" (200mm) to 12" (300mm)	9-inch
14" (350mm) to 18" (450mm)	12-inch

Note: For "H", "L", and "LL" dimensions, please refer to pages 103-106 in the TM100 Manual.

Equation for Selecting Insertion Flow Meter Probe Length.

Probe length = $\frac{1}{2}$ pipe ID (in inches) + 3" + thickness of insulation (if any) + 10" (for hot-tap if supplied). Round up to the next standard probe length available.

Note: Contact Sierra for longer probes.

Inline Styles

Inline pipe sizes, materials, and end connections are listed in the table below.

Inline pipe sizes in Inches =

0.75	○	●	◐	◑	1.00	○	●	◐	◑	1.25	○	●	◐	◑
1.50	○	●	◐	◑	2.00	○	●	◐	◑	2.50	○	●	◐	◑
3.00	○	●	◐	◑	4.00	○	●	◐	◑	6.00	○	●	◐	◑

Note: TM100 inline flow bodies include built-in flow conditioners. FlowTrak Flow Conditioners are available as an option for TM100 insertion flow meters.

○= SS ●= CS ◐= NPT Ends ◑= 150lb flanges

Ordering the TM100 Insertion

Instructions: To order a TM100 Insertion, please fill in each number block by selecting the codes from the corresponding features below and following pages.
Notes: The "Parent" model number and one of each "Feature" must be specified. Example: TM100-09I-DD-RS

PARENT	FEATURES			OPTIONS
	1	2	3	1
TM100	<input type="text"/>	<input type="text"/>	<input type="text"/>	<input type="text"/>

Parent	
TM100	Insertion Mass Flow meter; includes 4-20mA output and USB serial communication. TM-Cal Calibration Validation diagnostic for in-situ calibration in the field.

Feature 1: Probe	
06I	Insertion meter with 6-inch probe
09I	Insertion meter with 9-inch probe
12I	Insertion meter with 12-inch probe
15I	Insertion meter with 15-inch probe
18I	Insertion meter with 18-inch probe
24I	Insertion meter with 24-inch probe
30I	Insertion meter with 30-inch probe
36I	Insertion meter with 36-inch probe
15R	15-inch probe w/ 150-psi hot-tap & full port valve, 1" male NPT, 316 SS wetted parts
18R	18-inch probe w/ 150-psi hot-tap & full port valve, 1" male NPT, 316 SS wetted parts
24R	24-inch probe w/ 150-psi hot-tap & full port valve, 1" male NPT, 316 SS wetted parts
30R	30-inch probe w/ 150-psi hot-tap & full port valve, 1" male NPT, 316 SS wetted parts
36R	36-inch probe w/ 150-psi hot-tap & full port valve, 1" male NPT, 316 SS wetted parts

Feature 2: Display	
D0	No display & configuration panel
DD	Include rate/total display & configuration panel

Feature 3: Outputs and Serial Communication	
P1	4-20mA + Pulse Output
RS	4-20mA + RS485 (Modbus RTU or BACnet MS/TP - Field selectable)
BH	4-20mA / HART + Pulse Output

Option 1: Gas-Mix	
GasMix	Gas-Mix Function - Choose from preset list of 12 gases (or mix up to 5 gas components) in the field as needed. NIST-traceable calibration.

Ordering the TM100 Inline

Instructions: To order a TM100 Inline, please fill in each number block by selecting the codes from the corresponding features below and following pages.
Notes: The "Parent" model number and one of each "Feature" must be specified. Example: TM100-20P-DD-RS

PARENT	FEATURES			OPTIONS
	1	2	3	1
TM100	<input type="text"/>	<input type="text"/>	<input type="text"/>	<input type="text"/>

Parent	
TM100	Inline Mass Flow meter; includes 4-20mA output and USB serial communication. TM-Cal Calibration Validation diagnostic for in-situ calibration in the field.

Feature 1: 316 Stainless Steel Flow Body	
075P	3/4 inch flow body (schedule 40), male NPT ends, 12" face-to-face length
10P	1 inch flow body (schedule 40), male NPT ends, 12" face-to-face length
125P	1-1/4 inch flow body (schedule 40), male NPT ends, 12" face-to-face length
15P	1-1/2 inch flow body (schedule 40), male NPT ends, 12" face-to-face length
20P	2 inch flow body (schedule 40), male NPT ends, 12" face-to-face length
25P	2-1/2 inch flow body (schedule 40), male NPT ends, 18" face-to-face length
30P	3 inch flow body (schedule 40), male NPT ends, 18" face-to-face length
075F	3/4 inch flow body (schedule 40), 150# RF flange ends, 12" face-to-face length
10F	1 inch flow body (schedule 40), 150# RF flange ends, 12" face-to-face length
125F	1-1/4 inch flow body (schedule 40), 150# RF flange ends, 12" face-to-face length
15F	1-1/2 inch flow body (schedule 40), 150# RF flange ends, 12" face-to-face length
20F	2 inch flow body (schedule 40), 150# RF flange ends, 12" face-to-face length
25F	2-1/2 inch flow body (schedule 40), 150# RF flange ends, 18" face-to-face length
30F	3 inch flow body (schedule 40), 150# RF flange ends, 18" face-to-face length
40F**	4 inch flow body (schedule 40), 150# RF flange ends, 18" face-to-face length
60F**	6 inch flow body (schedule 40), 150# RF flange ends, 24" face-to-face length

Feature 1: A106 Grade B Carbon Steel Flow Body (w/ A105 flanges if ordered)	
20PC	2 inch flow body (schedule 40), male NPT ends, 12" face-to-face length
25PC	2-1/2 inch flow body (schedule 40), male NPT ends, 18" face-to-face length
30PC	3 inch flow body (schedule 40), male NPT ends, 18" face-to-face length
20FC	2 inch flow body (schedule 40), 150# RF flange ends, 12" face-to-face length
25FC	2-1/2 inch flow body (schedule 40), 150# RF flange ends, 18" face-to-face length
30FC	3 inch flow body (schedule 40), 150# RF flange ends, 18" face-to-face length
40FC**	4 inch flow body (schedule 40), 150# RF flange ends, 18" face-to-face length
60FC**	6 inch flow body (schedule 40), 150# RF flange ends, 24" face-to-face length

**Note: If max. flow rate above 2,500 SCFM (4,250 NM3H), consult factory for application review.

Feature 2: Display	
D0	No display & configuration panel
DD	Include rate/total display & configuration panel

Feature 3: Outputs and Serial Communication	
P1	4-20mA + Pulse Output
RS	4-20mA + RS485 (Modbus RTU or BACnet MS/TP - Field selectable)
BH	4-20mA / HART + Pulse Output

Option 1: Gas-Mix	
GasMix	Gas-Mix Function - Choose from preset list of 12 gases (or mix up to 5 gas components) in the field as needed. NIST-traceable calibration.



Measurably Different™

Sierra Instruments

North America

20 Ryan Ranch Rd, Suite 109
Monterey, California 93940
+1.831.373.0200 • sierrainstruments.com

EMEA

Bijlmansweid 2
1934RE Egmond aan den Hoef • The Netherlands
+31 72 5071400

Asia

Second Floor Building 5 • Senpu Industrial Park • 25 Hangdu
Road Hangtoun Town • Pu Dong New District • Shanghai, P.R.
China 201316 • +8621 5879 8521/22