



WATER LEVEL SENSOR

76-81GHz FMCW Non Contact Radar

Operating Manual



1. Product Introduction:

1.1 Main Feature:

RS-RD810 product refers to a frequency modulated continuous wave (FMCW) radar product operating at 76-81GHz. It has a high operating frequency and a larger bandwidth, so the measurement accuracy is higher. The maximum range of the product can reach 20m, and the blind zone is within 20 cm.

1.2 Technical Parameters

Transmit Frequency	76GHz~81GHz
Measuring Range	20m
Accuracy	±1‰FS
Beam Angle	3°
Power Supply	24V DC (22V ~ 30V)
Signal output	4~20mA/ RS485 Modbus
Antenna type/Material	Lens Antenna/PP
Housing Material	ABS or SS
Working Temperature	-20~+70°C
Working Humidity	(0%~95%) RH
Display	APP on Mobile phone (Bluetooth) "RADAR ME"
Protection Grade	IP66/67

1.3 Outer Dimensions

Unit:mm

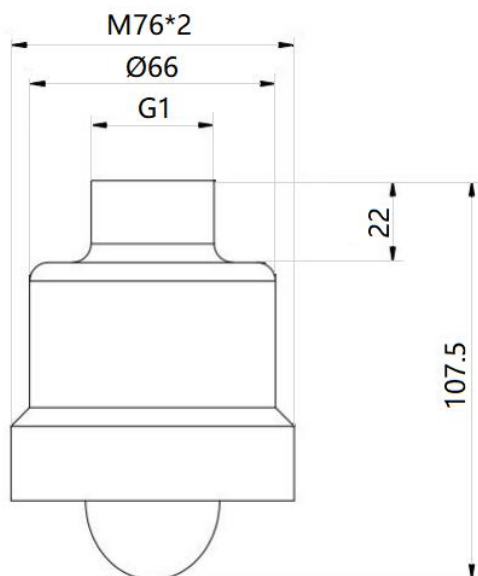

2. Installation

Two points need to be paid attention to during installation: (1) Ensure that the meter is perpendicular to the water surface (2) Avoid the emission beam irradiating the interference object and generating false echoes.

Please check the following points for typical operating conditions.

- Ensure that the water level sensor is installed perpendicular to the water surface, and the tilt will weaken the received signal amplitude and affect the normal ranging.

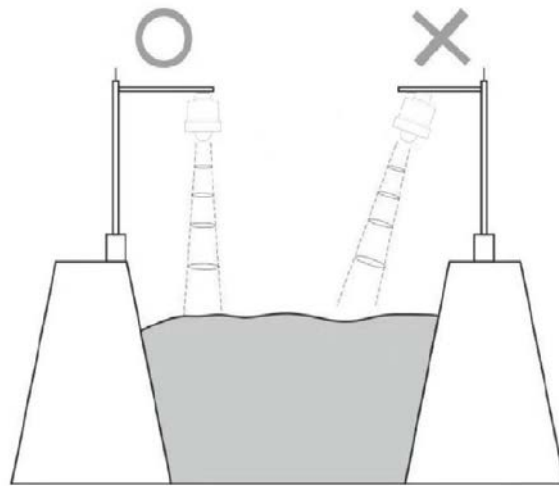

- Make sure that there are no interfering objects within the beam range, such as river banks.

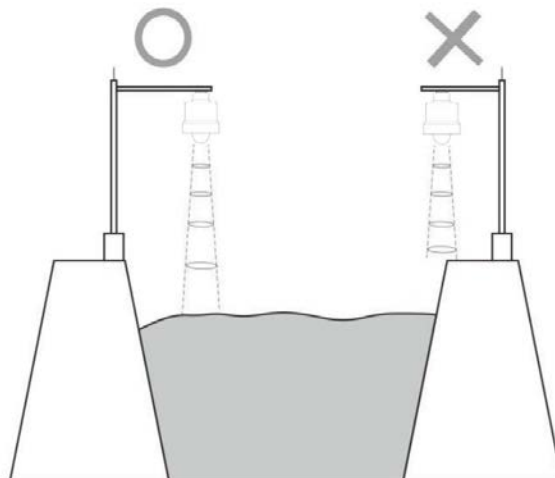

- The installation of the instrument should be at least 20cm away from the side wall, and the installation of the underground pipe network should be as close to the center of the water well as possible, otherwise the well wall will easily generate interference signals, which will affect the measurement and judgment, as shown in the figure below.

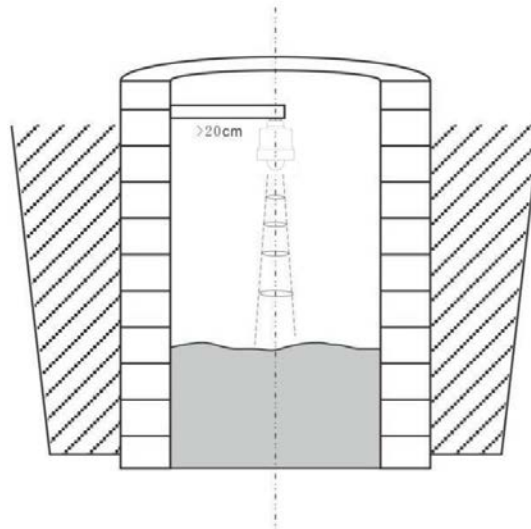

3.Wiring

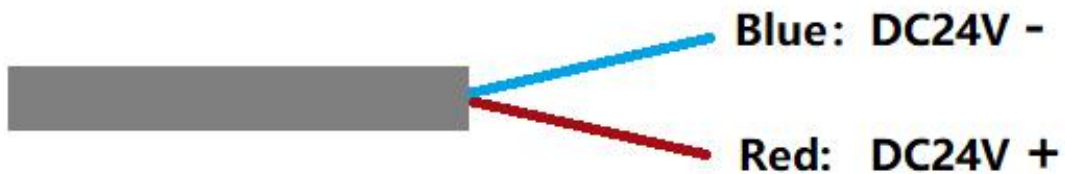

The radar water level sensor leads to two power lines, the red is connected to the positive pole of the power supply, and the black is connected to the negative pole of the power supply.

Note: the RTU is not included in the radar level sensor set.

4. Debugging and Setting

RS-RD810 performs liquid level measurement tasks according to the settings, which can be modified via Bluetooth and APP on Mobile.

4.1 Software Setting

Open the APP in the Mobile Phone, it display the device connection interface, as shown in the figure below:

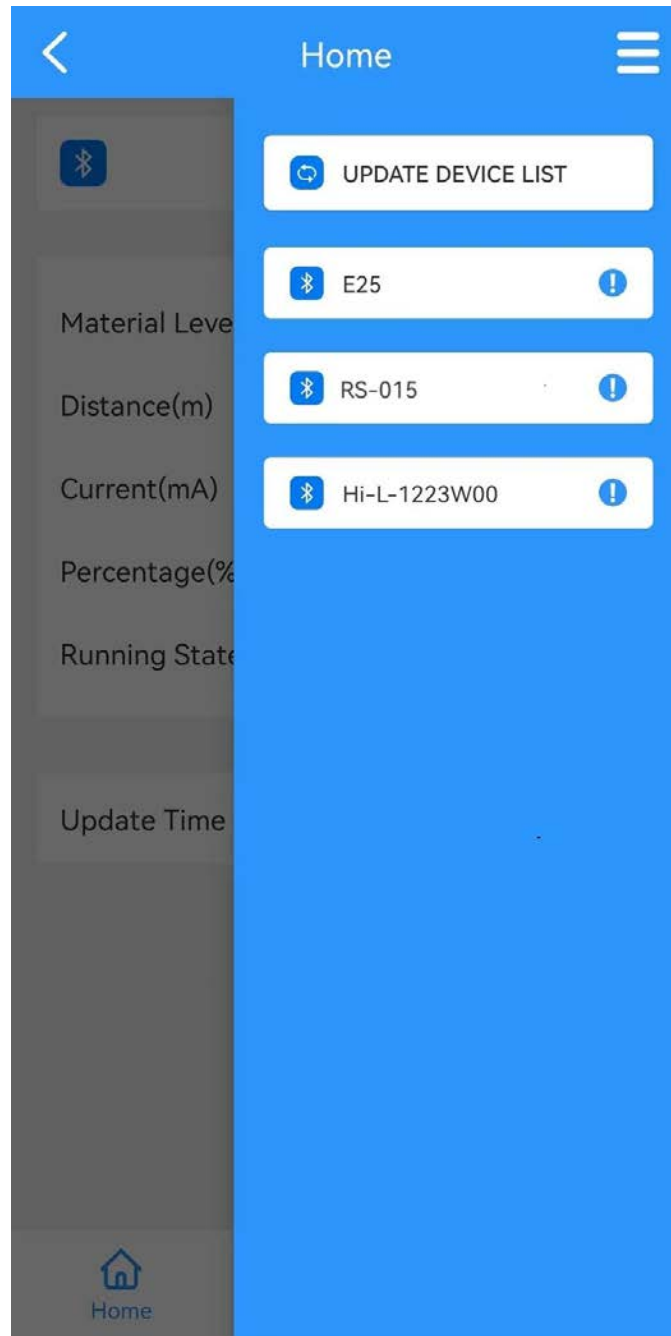

Click the name of the device to be set to enter the main interface, as shown in the figure below.

4.2 Main interface

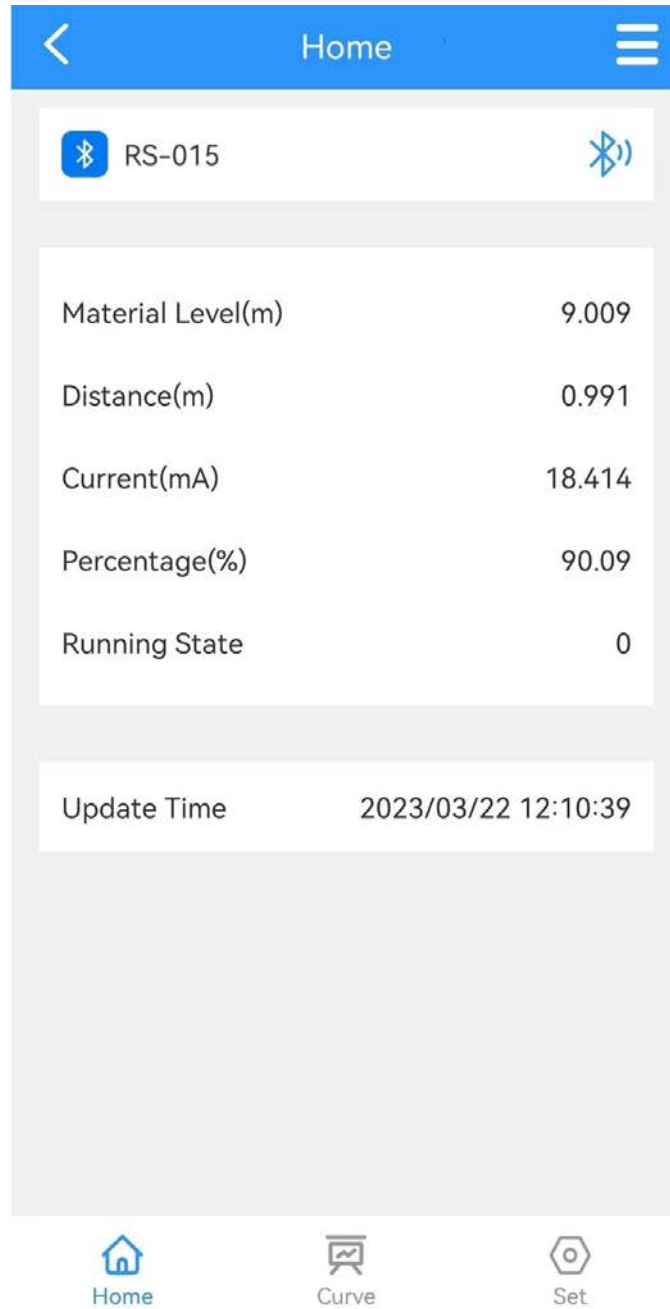

Click the “Curve” button at the bottom of the screen to enter the echo curve interface, as shown in the figure below:

4.3 Echo Curve Interface

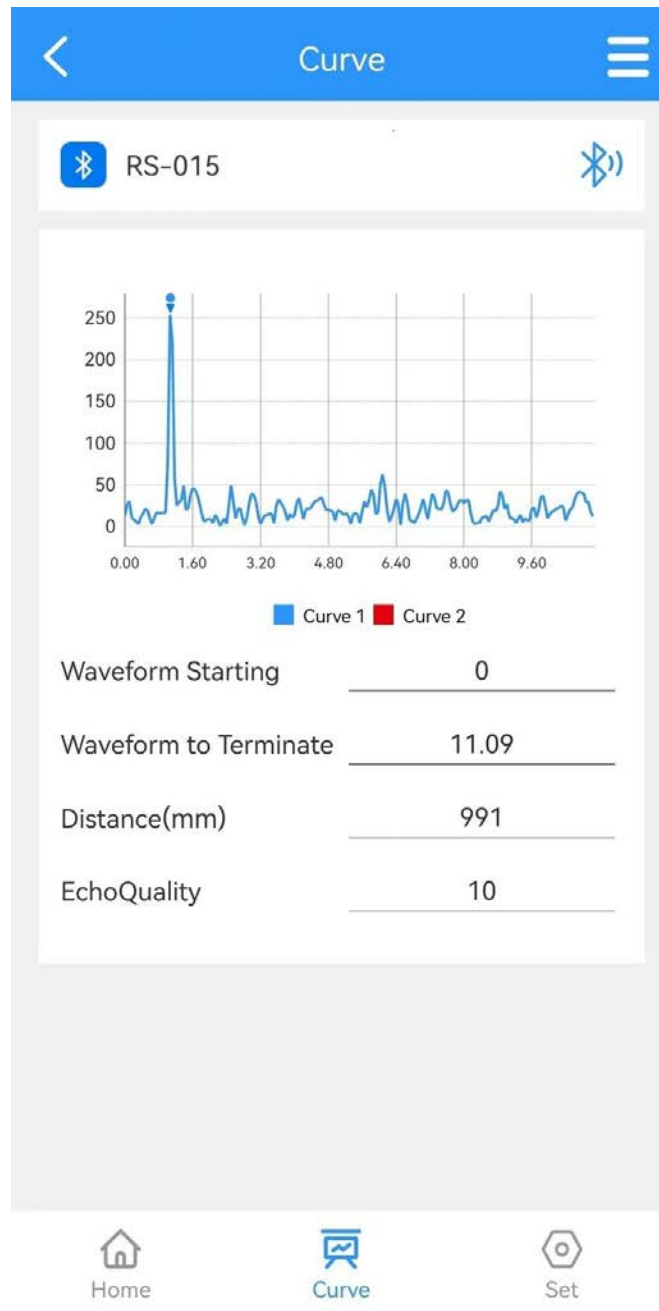

Click the “Set” button at the bottom of the screen to enter the parameter setting interface, as shown in the figure below.

4.4 Setting

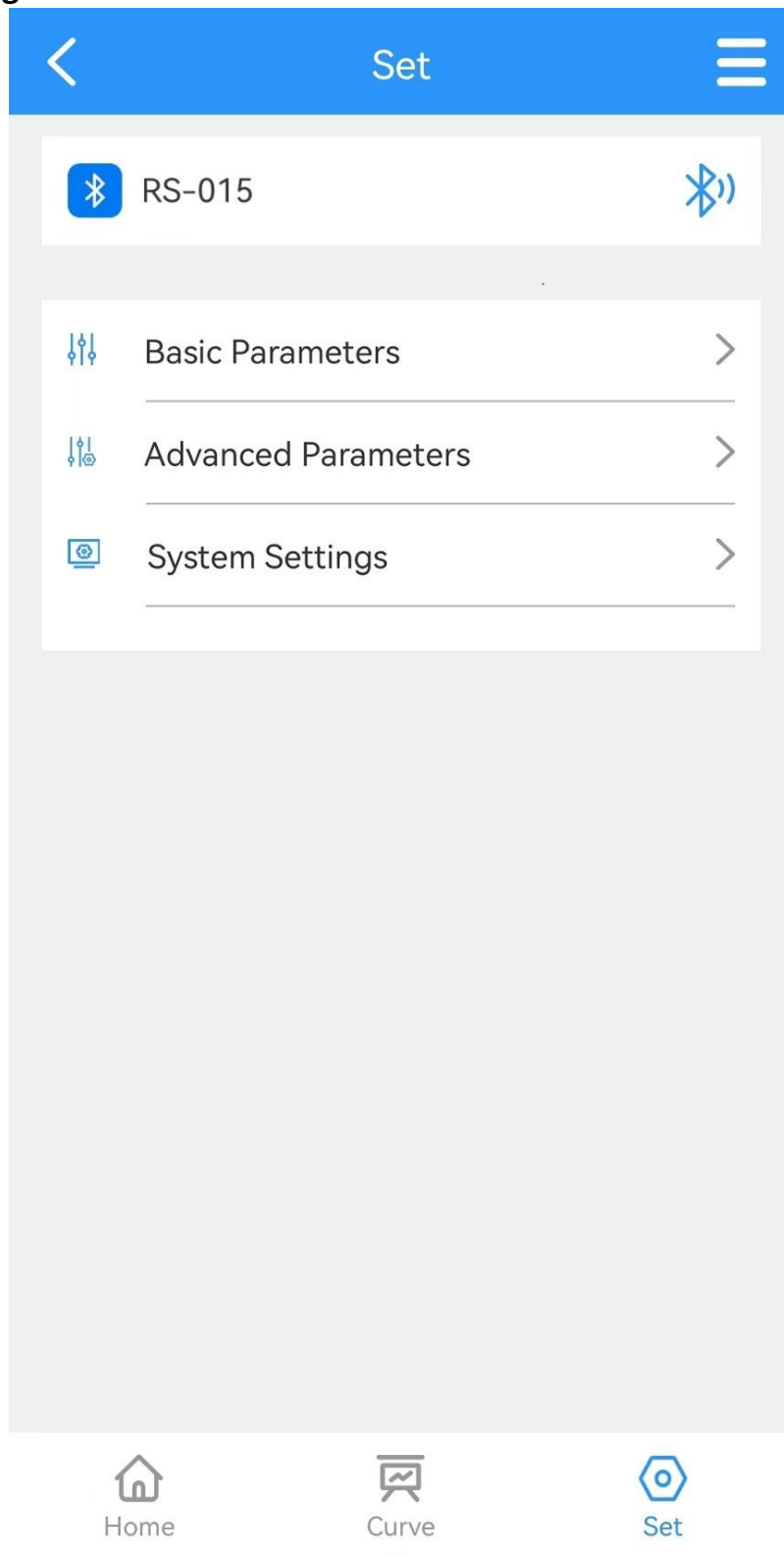





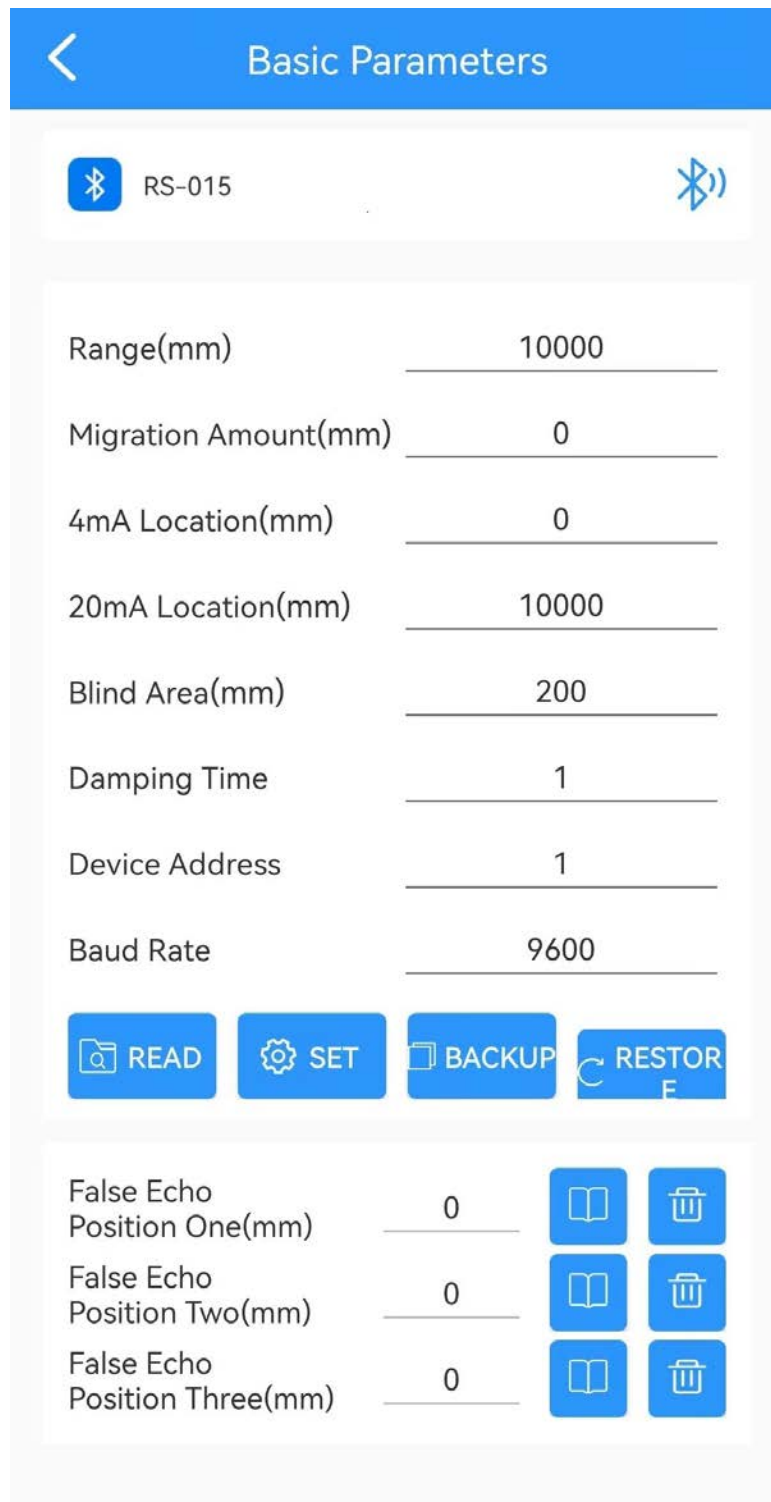

4.4.1 Basic parameters

Click the “Basic parameters” on the above interface, it shows below:



Parameter	Value
Range(mm)	10000
Migration Amount(mm)	0
4mA Location(mm)	0
20mA Location(mm)	10000
Blind Area(mm)	200
Damping Time	1
Device Address	1
Baud Rate	9600

Buttons: READ, SET, BACKUP, RESTORE

False Echo Position One(mm)	0		
False Echo Position Two(mm)	0		
False Echo Position Three(mm)	0		

Set the “Range” according to the working conditions and directly click the number input box behind to modify it. The rest of the parameters are modified in the same way.

Click the “ Read” button to refresh the parameters.

The 4mA location and 20mA location must be within the range, and the relationship between the 4mA location/20mA location and the range is shown in the figure below:

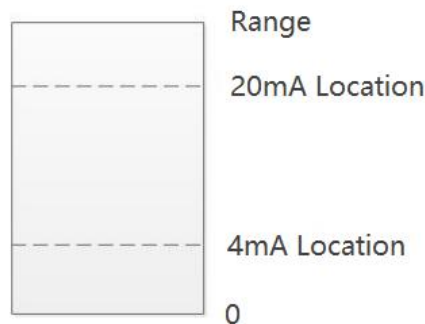

As shown in the figure, when the liquid level is lower than 4mA Location, the main interface displays the liquids level as 0; when the liquid level is higher than the 20mA location, the main interface displays the liquid level value as the value of 20mA location.

◆ Parameters definition--Basic setting

Range (500~50000) mm	Farthest distance that the gauge can measure.
Migration Amount (-9999~9999) mm	According to specific working conditions.
4 mA Location	Liquid level corresponding to 4mA current output, Unit:mm.
20 mA Location	Liquid level corresponding to 20mA current output, Unit:mm.
Blind Area	Values range from 200mm~ measuring range, according to specific working conditions. Unit: mm
Damping Time	In order to improve the stability of the measured output value, a large [damping time] can be set to stabilize the measured value and increase the anti-interference ability. For example: If the damping time is 10, the level of the measured object undergoes a step change at time T, and the measured output value follows the actual position of the measured object after 10 seconds.
Device Address	Slave address in RS-485 communication, that is, the local address (value range: 1-99, default value is 1)
Baud Rate	The baud rate in RS-485 communication, the default is 9600.

Backup the parameters: After the working parameters are backed up, if there is an error in manually modifying the parameters and the original working parameters are forgotten, the working parameters can be “ restore” in the basic settings.

Restore the parameters: It is used to restore the backup parameters.

5. Maintenance

- Pay attention to keep the radar level sensor clean, try to be waterproof, moisture-proof, anti-corrosion and avoid violent collisions and blows from other objects.
- Avoid direct sunlight on the main body of radar level sensor, keep away from heat sources and pay attention to ventilation. If the ambient temperature exceeds the rated temperature, corresponding cooling protection measures should be taken.
- When the ambient temperature is too low, an instrument protection box or other protective devices can be used for antifreeze protection, and keep the radar dry.
- The radar should be tested regularly. (the detection cycle is determined by the user according to the specific situation)

6. Measurement problem analysis

Symptoms	Cause of issue	Solution
No display	Power Supply	Check whether the DC 24V voltage and current meet the requirements or not.
	Wiring	Check the wiring is correct or not.
Unstable Value	Strong fluctuating	Change the installation position of the radar or reduce the fluctuation of the object to be measured.
	Weak Echo	Try angle alignment or rotate the radar mount.
	Strong Electromagnetic interference	Connect to the host to the ground or add a shield.