

S-PT-4S-DP

Pressure Transmitter

User Manual

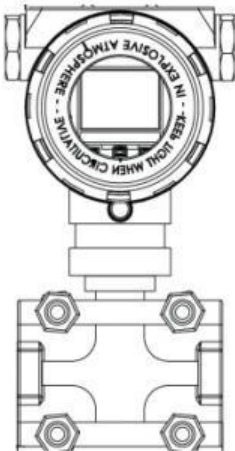

Warning

1. Please place the transmitter horizontally before calibration.
2. After the transmitter is installed on site, please deal with the transmitter zero adjustment.
3. The process connections should be installed and tightened before the transmitter is pressurized.
4. The transmitter should be installed in a dry environment, avoid rain erosion. In harsh environments, a protection box should be used to protect the transmitter.
5. Don't disassemble the transmitter.
6. When transmitter is powered, don't remove the transmitter covers in an explosive /flammable environment.
7. User should check whether the power supply voltage meet the requirements of transmitter user manual.
8. Transmitter external ground screw should be securely connected with the earth.
9. The transmitter in an explosive environment must be installed in accordance with international, national and local standards, codes, and practices. Please refer to the manual restrictions associated section listed for safe installation
10. Intrinsically safe transmitter external installation with the use of safety barriers shall be carried out according to their instructions.
11. Transmitter calibration and temperature compensation with HART communication, must use communications equipment and software provided by our company.

Content

Introduction.....	1
I. Summary.....	2
1.1 Overall shape	2
1.2 Transmitter working principle.....	2
II. Installation.....	4
2.1 On site installation.....	4
2.2 Measurement-related issues.....	6
2.3 Electrical Installation	9
2.4 Intrinsically safe ex-proof transmitter system wiring diagram...10	
2.5 Flameproof proof transmitter instructions.....	11
III. Debugging & Operation.....	12
3.1 Overview.....	12
3.2 Button operation of transmitters without LCD display.....	12
3.3 Button operation of transmitters with LCD display.....	13
IV. Flange Type Transmitter Instruction.....	16
4.1 Overview.....	16
4.2 Mounting position.....	17
4.3 Instrument calibration.....	17

Introduction

Our company's smart transmitter is a versatile digital instrument, It is well-designed by advanced, mature, reliable silicon sensor or capacitive sensor technology, based on the combination of advanced SCM technology and sensor digital conversion techniques.

Core components SCM, its powerful features and high-speed computing power ensure the excellent quality of the transmitter. The whole design framework focuses on reliability, stability, high accuracy and intelligent.

It has a powerful interface operation function,digital pressure meter can display pressure, the percentage, power current, and 0 to 100% analog instructions. In the absence of standard pressure source, the press button operation can be easily made to complete zero shift, pressure range setting, damping setting, basic parameters setting. Which greatly facilitates the on-site calibration.

Signal conversion, signal acquisition and processing, and the current output adopt an integrated ASICS, so the transmitter has a stable, reliable,anti-vibration etc features, as well as good interchangeability.

I. Summary

1.1 Overall shape

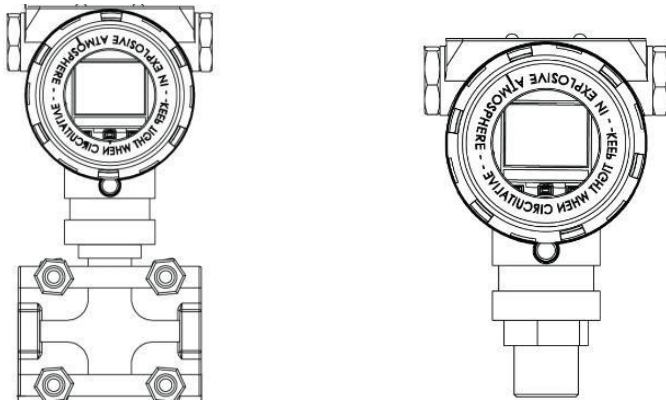

1.2 Intelligent transmitter working principle

1.2.1 Working principle

Figure 1-1 is the basic principle of intelligent electrical block diagram of the transmitter. The following describe how it works and function of each part.

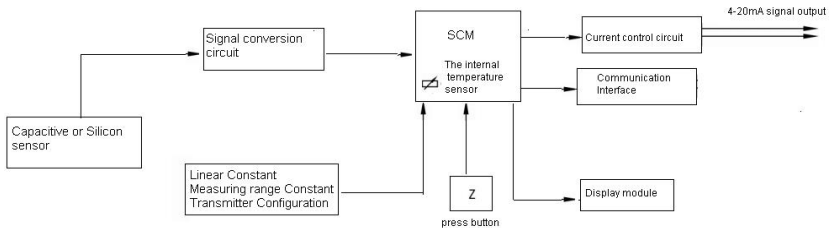

Figure1-1 Diagram of the transmitter principle

1.2.2 Smart circuit board

1) A / D converter

A / D converter circuit using a dedicated low-power integrated circuits, the analog demodulator output current is converted into digital quantity, accuracy up to 18 bits(digit), provided as an input signal to the microprocessor.

2) Microprocessor

Microprocessor smart transmitter control A / D and D / A conversion work, but can also achieve complete self-diagnostics and digital communications. In operation, a digital pressure value is handled by the microprocessor, and as a digital storage to ensure the conversion precision correction and engineering units. In addition, the microprocessor can complete linearization of the sensor, turndown ratio, damping time setting and other functions.

3) EEPROM memory

EEPROM to store all configuration, characterization and digital fine-tuning parameters, this memory is nonvolatile, so that even if the power failure, the stored data is still intact kept in readiness for intelligent communications.

4) D / A converter

D / A converter the corrected digital signal from microprocessor into 4 ~ 20mA analog signal and outputs it to the circuit.

5) Digital Communication

Transmitters with HART protocol via a communication device, the smart transmitter testing and configuration. Or complete communication through any support HART communication protocol of the host system host. When HART protocol uses industry-standard BELL202 frequency phase shift keying (FSK) technology to 1200Hz or 2000Hz digital signal superimposed communicate, communicate on the 4 ~ 20mA signal, the frequency of the signal 4 ~ 20mA process does not produce any interference . No HART protocol transmitters can be tested and configured for smart transmitter through a dedicated adapter and software.

6) display and press button

Smart Transmitter with LCD can display the pressure transmitter measured value, current value, from 0% to 100% proportional display and temperature value of sensor, meanwhile the transmitter can be configured via the buttons on the LCD panel .

Smart Transmitter without display can also be cleared by the transmitter, active calibration operation by S and Z buttons on the circuit panel.

II. Installation

2.1 On site installation

2.1.1 Mounting

Our pressure transmitter can be mounted directly on a 2-inch pipe Or directly mounted on the wall and on the dashboard. (Figure 2-1 and Figure 2-2)

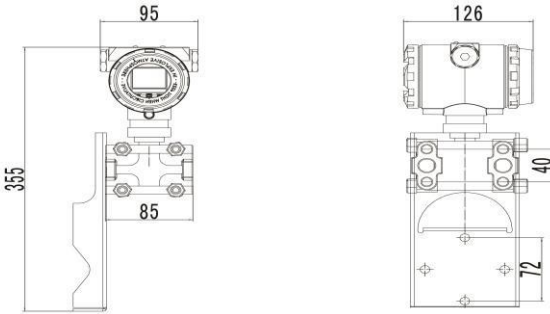

Figure 2-1 Capacitive Transmitter Installation

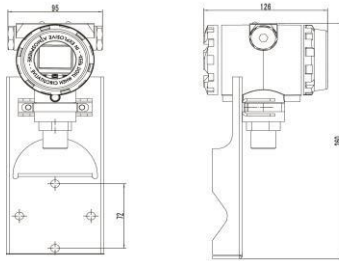

Figure 2-2 Piezoresistive Silicon Transmitter Installation

After locking screw loose, vault portion can be left, right rotation 90°. As shown in Figure 2-3.

Warning: Do not exceed 90° rotation, to avoid internal cable break!

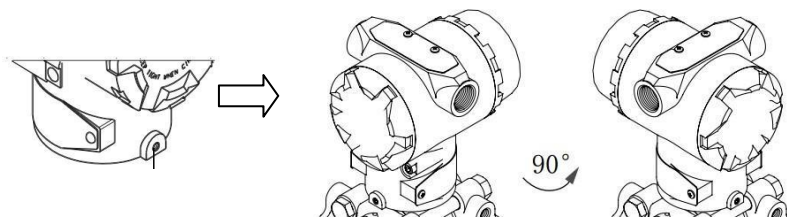

Figure 2-3 Housing rotating

2.1.2 Pressure impulsing (installation) mode

Capacitive transmitter installation has following three ways, as shown in figure 2-4 :

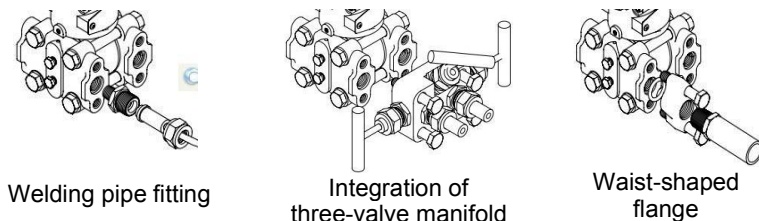

Figure 2-4 Capacitive pressure transmitter pressure impulse mode

The piezoresistive transmitter installation mainly are threaded connection, the user can equip with impulse welded per the thread size and spec.

2.1.3 Differential pressure transmitter process connection hole distance adjustment

Process connection holes in the pressure chamber is 1 / 4-18NPT. These process connection hole requires thread sealing. Just remove the upper & lower bolt of connectors on the use of waist-shaped flange joints, the transmitter can be easily removed from the production unit. Two flow connection hole center distance is 54mm. Rotation of the waist-shaped flange joint center distance can become 50.8mm, 54mm, 57.2mm as figure 2-5 shows:

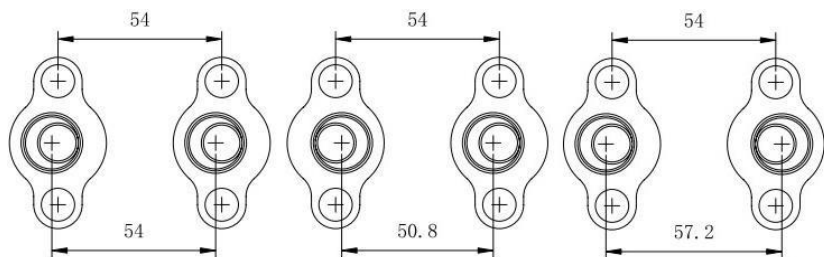

Figure 2-5 Differential pressure transmitter connection hole distance

2.1.4 Installation precautions

- 1, Prevent the transmitter in contact with the measured medium of corrosive or high temperature ($\geq 90\text{ }^{\circ}\text{C}$).
- 2, To prevent the waste deposited in the impulse pipe.
- 3, The connecting pipe to be as short as possible.
- 4, the liquid column pressure head of the differential pressure transmitter pressure on both sides of the guide tube should be balanced.
- 5, Connecting pipe should be installed in a place where temperature gradient and temperature fluctuations is small.
- 6, Prevent impulse lines crystallization or freezing cold.

2.2 Measurement related issues

Liquid Measurement:

When measuring the liquid flow, the pressure taps should be placed in the side of the flow of the pipeline to avoid the precipitation of dross. At the same time, please install the transmitter beside or below the taps, so that bubbles discharged into the flow of the pipeline.

Gas measurement:

When the measurement of gas flow rate, the pressure taps should be opened in the top or side of the process pipe. And the transmitter should be installed next to or above the process piping so that the accumulation of liquid can drain into the flow line.

Steam measurement:

When measuring steam flow, the pressure taps should be opened on the side of the flow line, and the transmitter is mounted below the taps so liquid can be filled with cold fusion in impulse tube. It should be noted that, in the measurement of steam or other high temperature medium, the temperature should not exceed the temperature limit of transmitter.

When measured medium is steam, connecting pipe to be filled with water to prevent steam directly contact with the transmitter, by this way when the transmitter works, the volume variation is negligible and does not require installation of the condensation chamber.

Level measurement:

Differential pressure transmitter for measuring liquid level, in fact, is a measure of the liquid column hydrostatic head. This pressure is determined by the proportion of high and low level and liquid level to take its size is equal to the pressure multiplied by the proportion of the height above the mouth of the liquid, regardless of the volume or shape of the container.

■ Level measurement of opening container

When measuring container opening level transmitter mounted near the bottom of the container, so as to measure its height above the level corresponding to the pressure. Tank level of pressure acting on the high pressure side of the transmitter and the low pressure side through the atmosphere. If the minimum level of the measured liquid level variation range of the transmitter is installed at the top, the transmitter must be positive transfer.

■ Level measurement in closed container

In a closed container, the pressure above the liquid container P_0 affect the measured pressure at the bottom of the container. Thus, the bottom of the pressure vessel is equal to the height multiplied by the liquid specific gravity coupled with liquid sealed vessel pressure P_0 . To truly level measured at the bottom of the pressure vessel should be measured by subtracting the pressure vessel P_0 . To this end, a top of the container to open the taps, and connect it to the low pressure side of the transmitter. Such pressure in the container on simultaneously on high and low side of the transmitter. The results obtained are proportional to the differential pressure on the liquid surface height and the proportion of the product.

■ Pressure connection

1) Dry impulse pressure connection

If the gas above the liquid is non-condensing, transmitter low-pressure side connecting pipe remains dry. This condition is called dry impulse connection. The method to decide the transmitter measuring range is same as opening container level

2) Wet impulse pressure connection

If the gas above the liquid appear condensation, impulse pipe of transmitter low pressure side will gradually accumulate the liquid, causing measurement error. To eliminate this error, advance with a liquid filling the impulse piping of transmitter low-pressure side, this condition is called wet impulse connection. The above-mentioned case, make the low-pressure side of the transmitter has a pressure head, so a negative migration is needed.

Method of reducing deviation

Impulse pipe control the transmitter and process pipe flow together, and the process pressure taps at the track transferred to the transmitter. Pressure transmission, the reasons of causing errors as following:

- 1) Leakage;
- 2) Abrasive wear loss (especially when using the cleansing agent);
- 3) Liquid pipeline has gas (causing head error);
- 4) Gas pipeline accumulating liquid (causing head error);
- 5) Density between both sides of the connecting pipe difference due to temperature differences (causing head error);

Deviation reduction method is as follows:

- 1) Impulse pipe should be as short as possible;
- 2) When measuring liquids or steam, connecting pipe shall be upward connected to the process pipeline, its slope should be less than 1/12;
- 3) For vapor measurement, impulse pipe should be downward connected to the process under the process piping, its slope should be not less than 1/12;
- 4) The layout of liquid impulse pipe should avoid high points occur at intermediate, the layout of impulse pipe of gas should avoid low points occur at intermediate
- 5) Two impulse pipes should maintain the same temperature;
- 6) In order to avoid friction effects, the impulse pipe diameter should be large enough;
- 7) Filled with a liquid connecting pipe should be no presence of gas;
- 8) When using an isolation liquid, on both sides of the pressure guide tube the liquid should be same;
- 9) When adoption of clean agents, cleansing agents should close to the

connection process piping taps, cleansing agent through the pipeline, which should be the same length and diameter, cleansing agents should be not through the transmitter.

2.3 Electrical Installation

System wiring diagram :

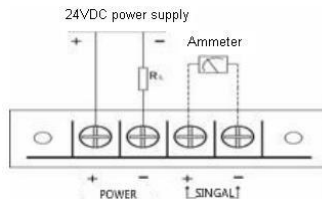

Figure 2-6

(Note 1: User equip distributor or barrier according to on site or design requirements, for details please reference usage methods of distributor, barrier.)

Recommended to choose connection proof cable lead-in terminals, cable diameter $\phi 8 \sim \phi 12$. Provided on the terminal end of the test, the operator easy online test. Signal terminals are located in a separate compartment of the electrical box. Unscrew the cover can be wiring. The above terminals are signal terminals, the following table is a test terminal terminal. Figure 2-11 depicts the location of the terminal, took the test terminals for optional indicating meter or for testing, power is supplied through the signal line to the transmitter, no additional wiring.

Special Attention :

Do not put the signal line with the power supply to the test terminal, otherwise it will destroy the diode inside test terminals.

If diodes accidentally damaged, shorting the transmitter test terminal can continue to work, but can not connected to this transmitter instruction meter. Signal lines no need shield, but the use of the strand better. Do not put the

signal line and other power line together, or close to high-voltage installations. Threading hole on the transmitter housing should be sealed or coated with a sealant inserted plug, this is to prevent moisture accumulation in the housing. If the patch wire is not sealed, the transmitter should be installed by stringing holes down to drain the water.

The signal line may not be grounded (floating) or grounded at any point on the signal loop. The transmitter housing may be grounded or ungrounded, The power does not have to voltage stabilization, even if the power ripple peak - there is 1V, while the transmitter output ripple is still ignored. Because the transmitter coupled to ground through a capacitor, a high voltage is not applied megger to check the insulation resistance. Voltage used to check the line should not exceed 100V.

The transmitter circuit is designed to intrinsically safe circuit, the output current is limited to 24mA DC or less (under high temperature or high power supply voltage is 24mA DC).

2.4 Intrinsically safe explosion proof transmitter system wiring diagram

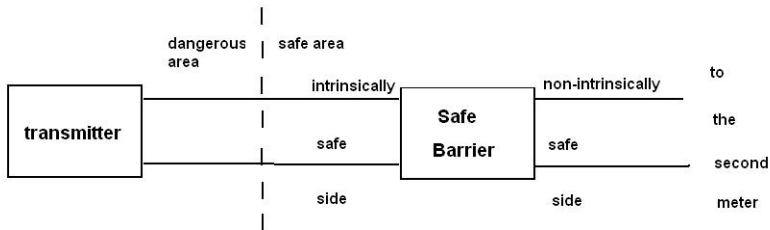

U_i :28v DC

I_i :30mA

P_i :0.84W

$U_m \geq 250V$ AC/DC

$U_o \leq 28V$ DC

$I_o \leq 30mA$

Remark :

- ① $V_m, V_o, I_o, P_o, V_i, I_i, P_i$ definition refer to GB3836、4-2000 standard。
- ② Connecting wires or cables between the barrier and the maximum allowable transmitter distributed capacitance C_P is not more than 0.02 μ F, the maximum allowable distributed inductance L_P is not greater than 2.0mH.

2.5 Flameproof transmitter instructions

■ Flameproof transmitter installation should pay attention to the protect explosion proof joint and anti explosion measures; The cap must be spinned completely and locking the locking apparatus; Housing to the ground; During loading should prevent parts in the plane gap becomes larger due to plane crash, scratch hurt; Preventing the housing from fall damage etc to not reduce the strength; After instrument maintenance & inspection completed, all of the screws, housings, wiring must be tightened, not damaged, otherwise will loss explosion proof performance.

■Flame proof transmitter must not be opened or loose cover or the housing when transmitter is powered.

■Two outlet of flame proof transmitter, use one to connect with cable wiring, the cable connector should use special clamp nut flameproof glands. Tighten the hollow bolts, washers, rubber seal over the cable outer diameter, into the interface and tighten, ensure the seal is tightened on the cable outer diameter of the cable outer diameter, hollow bolt must be screwed into the threaded over six or more. Another outlet port must be fitted with a sealed rubber band, washers, solid bolt, solid bolts must be tightened, screw threading must be over 6 Threaded above. To achieve the proof requirements, should use cable type KVVV 1.5 * 4 core outer diameter 10mm (10.5mmMAX) cable.

■Structures and parts flameproof explosion-proof transmitter strictly according to standards of inspection and testing, in accordance with the national standard GB3836.2-2000 《 explosive environments with explosion-proof electrical equipment flameproof electrical equipment" d " 》 , the standard is EXds II BT5.

III. Debugging & Operation

3.1 Overview

Panel of Fig without LCD

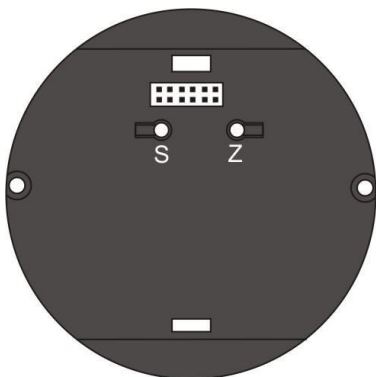

Figure 3-1

Panel of Fig with LCD

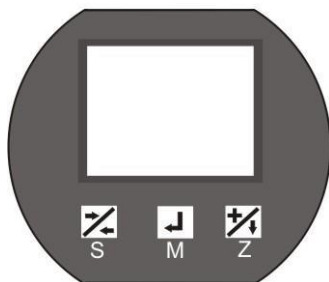

Figure 3-2

3.2 Button operation of transmitter without LCD

When the transmitter no display header, use the circuit board carrying the keys S and Z (shown in Figure 3-1) can do the following operation

3.2.1 Zero clearing

Ensure that the transmitter is powered on and in a zero-pressure compressed state, while holding down the S key and Z button for 5 seconds and above, then release the two buttons at the same time, then press and hold the two button again holding about 2 seconds, the transmitter errors will be the cleared and current value will be accurate.

3.2.2 Calibrate the lower limit (zero active migration)

Ensure the transmitter is powered on and in a pressure range lower limit state, while holding down the S key and Z button for 5 seconds, then release the two buttons at the same time, hold down the Z button again for about two seconds, the transmitter make the current pressure as the range lower limit, but it does not change the range of the transmitter. For example: the transmitter's range is 0-5kPa, the current pressure is -1kPa, after the implementation of this operation, the transmitter's range becomes -1-4kPa.

3.2.3 Calibrate the upper limit (full-point calibration)



Ensure the transmitter is powered on and in a pressure range lower limit state, while holding down the S key and Z button for 5 seconds, then release the two buttons at the same time, hold down the S button again for about two seconds, the transmitter make the current pressure as range upper limit, but does not change the lower limit of the range of the transmitter. For example: the transmitter's range is 0-5kPa, the current pressure is 4kPa, after the implementation of this operation, the transmitter's range becomes 0-4kPa.

3.3 With LCD transmitter button operation

When the transmitter with the LCD meter, the transmitter can not only achieve the described operations as 3.2 describe, you can also use the three buttons on LCD meter for the configuration parameters of the transmitter, the keys see Figure 3-2.

Note: If the transmitter parameters can not be modified, modify the menu item "write-protect" to "OFF."

3.3.1 Key(button) Description

Key icon	Key name	Key function
	S	Under menu status it means <u>Return</u> , under parameter setting it means <u>shift</u> this key also has the function of S key under item 3.2
	M	Menu and parameter <u>Confirmation</u> key.
	Z	Under menu status it is <u>Choose</u> function, under parameter setting it means <u>+1</u> , this key also has the function of Z key under item 3.2

3.3.2 Menu Structure

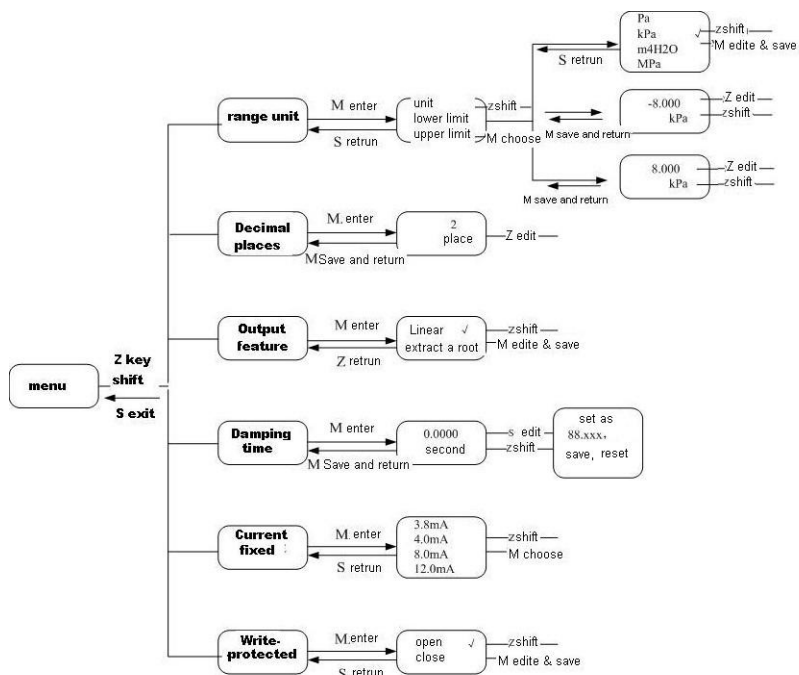

3.3.3 Configuring the operating

When you want to configure the transmitter, to ensure that the transmitter is powered and work in the measurement display, press and hold the M button for about 5 seconds to display the main menu then you release the button to enters the configuration menu, press the S key to return the main menu, press the Z key to select menu items, M key to enter.

When entering the specific parameter setting interface, press the S key to cycle through the selected digit to be modified, including numbers, the decimal point and negative sign. Press Z key to select the bit to modify, Digit place is+1, move the decimal point cycle, a negative sign for the positive and negative selection bit, press the M button to save the changes and return to the previous menu.

Examples:

■ Change unit

In the main menu,

*Press Z to move up &down for selections, select "scale unit", short press M to enter;

*Press Z to move up & down for selections, select "unit", short press M to enter;

*Press Z key to select the unit, short press M to confirm the selection, then appears "√" on the right indicates success, otherwise check if "write-protected" is "OFF";

*Press S to return to the previous level.

■ Modify the lower limit

In the main menu,

*Press Z to move up & down for selections, select "scale unit", short press M to enter;

*Press Z key to move up and down to select item, select the "lower limit", short press M to enter;

*Press the S key to select the bit to modify, press the Z key to modify the number, if no response button, check if the "write-protected" is "OFF";

*Press M to save and return to the previous level.

■ Factory reset

In the main menu,

*Press Z key to move up and down to select item, select the "damping time", short press M to enter;

*Press the S key to select the bit to modify, short press the Z key to modify the number, set the figure as "88.888";

*Press M to save, then the parameters of the transmitter will be restored to factory condition.

Other operations can be found in the menu structure.

Under the menu or parameter setting state when there is no key operation for about 15 seconds, the transmitter automatically exit the parameter configuration and return to the measurement state.

IV. Flange Type Transmitter Instruction

4.1 Overview

Capacitive flange differential pressure / pressure transmitter is the form of flange and the measured part of the transmitter connected, it applies to the following situations:

① need to isolate high temperature medium from transmitter;

② the measured medium is corrosive to the sensitive components of transmitter;

③ the measured medium is suspended liquid or has a high viscosity;

④ the measured medium easily cured or crystallized due to environmental temperature changes or process temperature changes;

⑤ replace the measured media need to be strictly purified measurement head;

⑥ The measuring head must be kept hygienic. Capacitive flange differential pressure, pressure transmitter is mainly used for continuous accurate measurement of liquid, gas, vapor pressure differential's pressure and liquid level, interface, density and other parameters. Equip with the throttle device can measure gas, liquid and vapor flow continuously, and transfer the measured signal into 4 ~ 20mA DC two-wire signal output, as the instructions, recording and regulator input signal to work with other units or industrial control computer, composed of automatic detection, recording, control and other industrial automation systems.

4.2.1 Mounting position:

Flange level transmitter is a flange mounted directly on the tank or tank wall. When the diaphragm is in the vertical position it is possible to change the zero point to a maximum of 28 mm H₂O. When the diaphragm is in the horizontal position, the zero point change is less than 100mmH₂O (for the inserting flange to add an insertion length change amount), but has no effect on the range, this error can be corrected and eliminated.

4.2.1.1 Remote flange mounting position

For the remote flange transmitter installation, there are certain restrictions for the pressure transmitter and flange height difference, and the two flange height difference. Details please see table as below:

range code	allowable height difference (unit: m)	
	silicon oil	fluorine oil
7F	3.84	1.89
7H	19.2	9.48
7M	no this restriction	

When the pressure transmitter and the flange or differential pressure transmitter's two flanges are not the same height, due to the liquid column in the remotecapillary, zero will change, the zero points should be readjusted.

4.2.1.2 The change of temperature and the environment of the measured medium will cause the drift of the zero point of the transmitter. Installation as follows can reduce the influence:

- 1, do not let direct sunlight to the transmitter and remote transmission device;
- 2, with the seasonal adjustment of zero;
- 3, to maintain the capillary constant temperature.

4.3 Instrument calibration

Flange transmitter calibration is same as the general principle of the transmitter, but need to have device for sealed connection with the flange, and thus given the test standard pressure.

4.3.1 Flange level transmitter

Flange level transmitter's usage notes: for the general viscosity of the media should choose a flat flange level transmitter; for the viscosity of large, easy to precipitate and suspension media a inserting flange level transmitter should be used, and the measurement diaphragm must be installed at the depth of the inner wall of the tower, at least into the inner wall of the tower. If the measured medium velocity & grinding ability is too big, and the diaphragm might be worn through by them, the user should take appropriate measures before usage. Single-level, single-insert flange level transmitter measurements are calculated the same way.

4.3.2 Usage of instrument without migration: (see figure below)

The instrument is mounted at the same level as the lowest level. When measuring the opening container, the instrument negative pressure membrane board through the atmosphere. When measuring the sealed container, the upper part of the container is connected with the negative pressure side membrane plate. If the negative pressure side can be kept dry at this time, no need to install condensate tank, or need to install the condensation tank, and the condensed condensate should be discharged regularly, the normally open drain valve should be closed, so that the transmitter not to withstand one-way pressure.

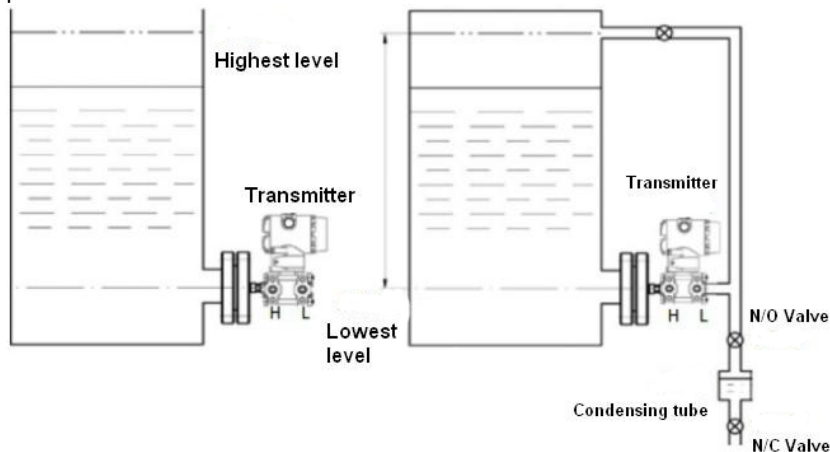

4.3.3 Usage of instrument with negative migration (see below)

If the installation of condensate tank is not convenient, or in order to isolate corrosive media into the negative side, you can use the isolation fluid as below figure 4, and the instrument under the differential pressure:

$$\Delta P = r_1 (H + H_0) - r_2 h = r_1 H - (r_2 h - r_1 H_0)$$

$$\text{Migration: } B = r_2 h - r_1 H_0$$

$$\text{Range: } P = r$$

For example, $r_1 = 1.4 \text{ g/cm}^3$ and $r_2 = 0.89 \text{ g/cm}^3$ are known

$H = 500 \text{ mm}$, $H_0 = 100 \text{ mm}$, $h = 1700 \text{ mm}$

Range: $\Delta P = r_1 \cdot 1 = 1.4 \times 500 = 2100 \text{ (mmH}_2\text{O)}$

Negative transition amount: $B = r_2 h - r_1 H_0 = 0.8 \times 700 - 1.4 \times 100 = 1220 \text{ (mmH}_2\text{O)}$

Before installation, adjust the range to $-1220 \sim 880 \text{ (mmH}_2\text{O)}$

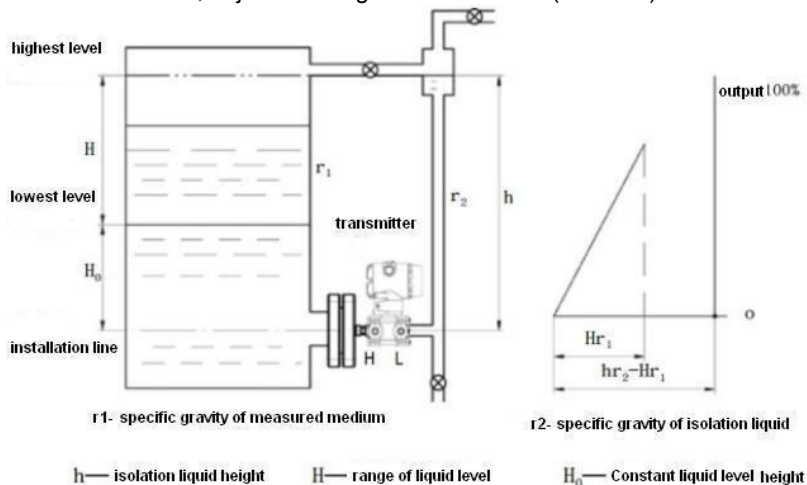

4.3.4 Usage of instrument with positive migration

When instrument installation position is under the lowest level, the usage is shown below:

Differential pressure: $\Delta P = (H_0 + H) \cdot r$

Positive migration: $A = H_0 r$

Example: the measured medium specific gravity $r = 1.1 \text{ g/cm}^3$, $H = 910 \text{ mm}$,
 $H_0 = 820 \text{ mm}$

Range: $P = H \cdot r = 910 \times 1.1 = 1001 \approx 1000 \text{ mmH}_2\text{O}$

Positive migration: $A = H_0 r = 820 \times 1.1 = 902 \approx 900 \text{ mmH}_2\text{O}$

The range must be adjusted to $900 \sim 1900 \text{ mmH}_2\text{O}$ before installation

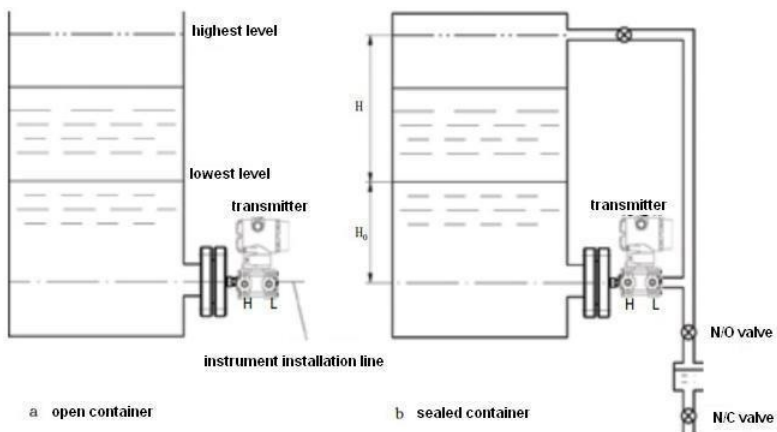

SMERI s.r.l.

Via Mario Idiomi 3/13

I - 20057 Assago MI

Tel. +39 02 539 8941

E-mail: smeri@smeri.com - www.smeri.com

