

Level control solutions for LNG/LPG application



Features of Trimod Besta Level Switches

- Designed for low temperature applications down to -196°C
- Suitable for densities as low as 0.32 kg/dm^3
- Extremely robust and outstanding lifespan
- Easy, fast and safe installation
- Safety integrity level: SIL1 and SIL2 (SIL3 capable)
- Approved by various ship register: ABS, BV, DNV-GL, LRS, RINA, RMRS, Class NK
- Certified acc. to ATEX, IECEx, EAC Ex (Russia), ISO 9001

Applications for Trimod Besta Level Switches

- For high and low alarm at reliquefaction plant. See page 3 to 10.
- For leakage monitoring, installed between hull and LNG/LPG tanks or within the double hulls. See page 11.
- For high and low alarm as well as for pump control in fuel oil, lubrication oil and ballast tanks, in the bilge, in drinking-, grey- and blackwater tanks, in incinerator units and many more. See page 16.



ClassNK



The 3-modular concept offers an unlimited variety of switches



Switch module Flange module Float modul

Switch modules

- Electric switch elements (Microswitch)
- Electronic switch elements (Proximity switch)
- Pneumatic switch elements (ON/OFF and proportional output)
- Explosion proof versions (Ex ed and Ex ia)
- Enclosure: IP65, IP66/67, IP68
- Aluminium and stainless steel housing
- Low/high temperature modules (-196°C to +400°C)

Flange modules

- Square flange, 92 x 92 mm, bolt circle 92 mm
- Round flange ø118 mm, bolt circle 92 mm
- Flanges acc. to EN/DIN, ANSI, JIS
- Stainless steel, Hastelloy C and plastic
- PN up to EN/DIN 320 and ANSI cl. 2500
- Special gaskets (Graphite, PTFE)

Float modules

- For low densities (min. 0.32 kg/dm³)
- In stainless steel, Hastelloy C and plastic
- For on/off and pump control
- For interface application, e.g. oil/water
- Horizontal and vertical mounting
- For high pressure application

Accessories

- Weld-on counterflanges in carbon and stainless steel for switches with bolt circle 92 mm
- Test actuator for manual and automatic function check

Horizontal mounting

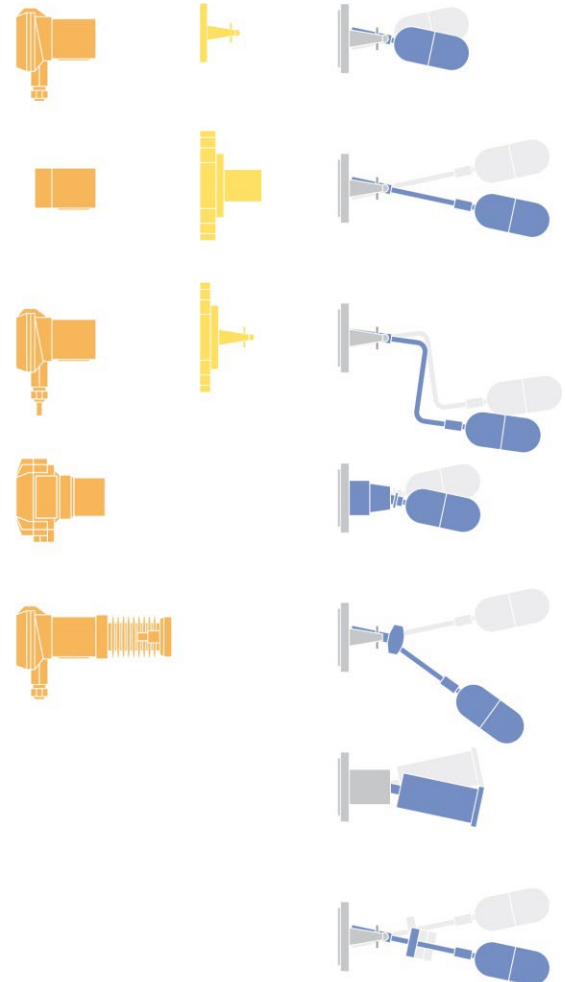

Vertical mounting



Main criterias for switch type selection

1. Ambient and operating (process) temperature
2. Minimum density of the liquid
3. Process pressure
4. Explosion proof design (Ex ed or Ex ia)

Minimum density and process temperature range for switch type ZK... (Ex ed)

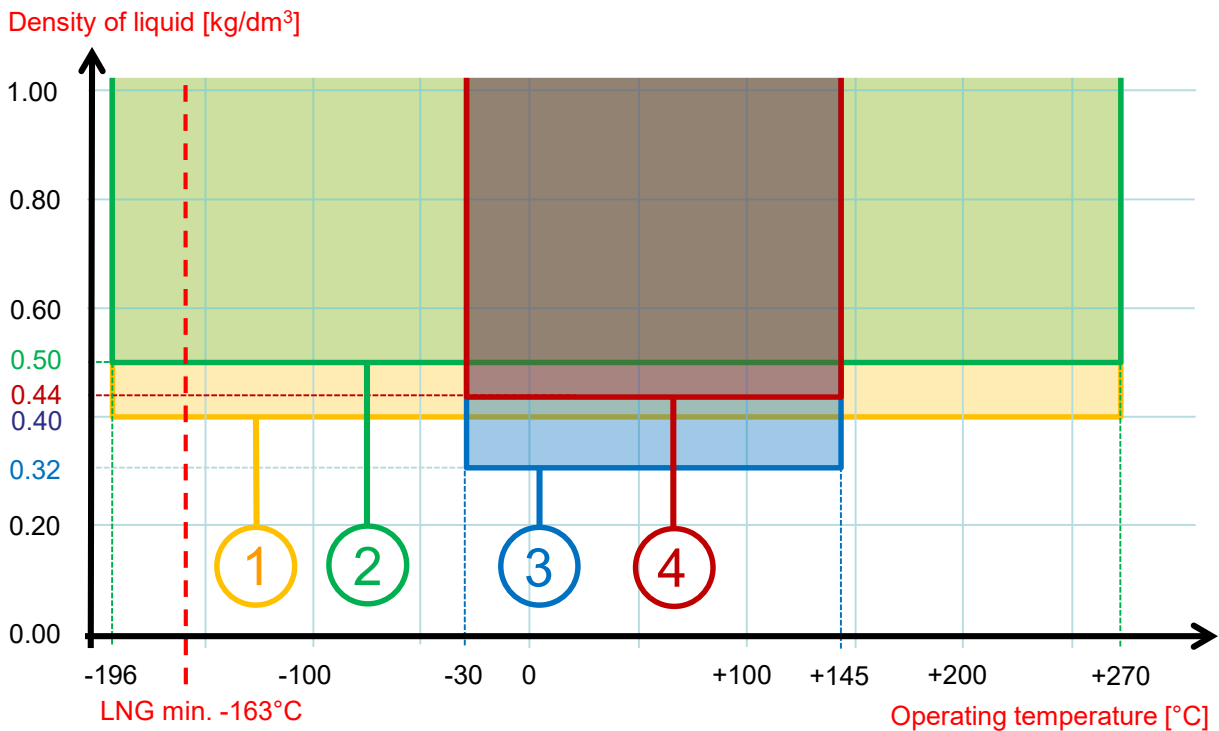

Minimum density and process temperature range for switch type B8... (Ex ia)

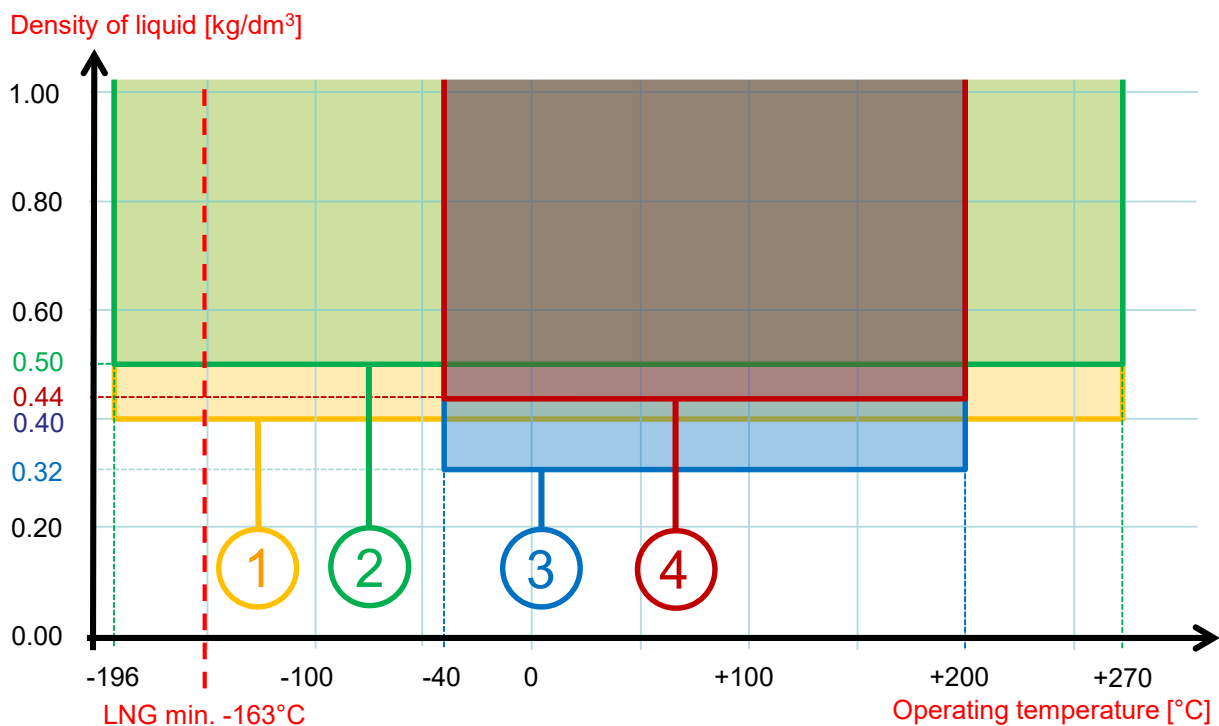

1

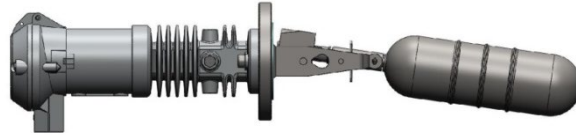

Type	ZTDK8E28 011Z 76	TDB8E28 011Z 76
	Ex ed (ATEX) , min. density: 0.4 kg/dm ³ , min. operating temperature: -196°C	Ex ia (ATEX) , min. density: 0.4 kg/dm ³ , min. operating temperature: -196°C
Nominal pressure	PN 25 acc. to DIN	PN 25 acc. to DIN
Operating temperature	a) -196°C to +270°C	-196°C to +270°C
Ambient temperature	a) -45°C to +80°C	-40°C to +80°C
Density of liquid	min. 0.4 kg/dm ³	min. 0.4 kg/dm ³
Operating differential	12 mm, fixed	12 mm, fixed
Wetside / flange material	stainless steel (CrNiMo/316 equiv.)	stainless steel (CrNiMo/316 equiv.)
Housing material	chromatized seawater resistant die cast aluminium	chromatized seawater resistant die cast aluminium
Housing gasket	Silicon O-rings (E28)	Silicon O-rings (E28)
Flange dimensions	ø118 mm, PCD 92 mm	ø118 mm, PCD 92 mm
Flange gasket	b) Graphite	Graphite
Switch element	hermetically sealed SPDT microswitch, silver contacts	SPDT microswitch, gold plated contacts
Switch rating	250 VAC, 5A / 30 VDC, 5A	for intrinsically safe circuits
Safety classification	Ex ed IIC T6...T5 Ga/Gb	Ex ia IIC T6 Ga/Gb
Certificate	EPS 12 ATEX 1430 X c)	EPS 12 ATEX 1430 X
Enclosure	IP66/IP67	IP66/IP67
Safety integrity level	SIL1 (SIL3 capable)	SIL1 (SIL3 capable)
SIL2 Version:	ZTDKK8E28 011Z 76 As type above but with: Dual SPDT microswitches	TDBB8E28 011Z 76 As type above but with: Dual SPDT microswitches

- a) Correlation of operating and ambient temperature see diagram page 8 and 9
- b) Option: PTFE gasket (E52) e.g. ZTDK8E28 011Z**E52** 76
- c) Option: IECEx (5), TR CU (1) approval, e.g. for IECEx: ZTDK**5**E28 011Z 76

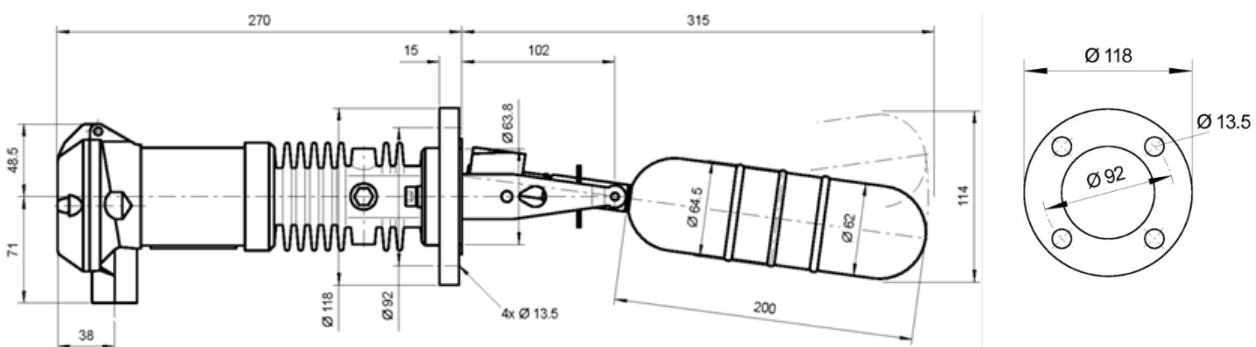

2



Type	ZTDK8E28 01 07 <i>Ex ed (ATEX)</i> , min. density: 0.5 kg/dm ³ , min. operating temperature: -196°C	TDB8E28 01 07 <i>Ex ia (ATEX)</i> , min. density: 0.5 kg/dm ³ , min. operating temperature: -196°C
Nominal pressure	PN 25 acc. to DIN	PN 25 acc. to DIN
Operating temperature a)	-196°C to +270°C	-196°C to +270°C
Ambient temperature a)	-45°C to +80°C	-40°C to +80°C
Density of liquid	min. 0.5 kg/dm ³	min. 0.5 kg/dm ³
Operating differential	12 mm, fixed	12 mm, fixed
Wetside / flange material	stainless steel (CrNiMo/316 equiv.)	stainless steel (CrNiMo/316 equiv.)
Housing material	chromatized seawater resistant die cast aluminium	chromatized seawater resistant die cast aluminium
Housing gasket	Silicon O-rings (E28)	Silicon O-rings (E28)
Flange dimensions	square 92 x 92 mm, PCD 92 mm	square 92 x 92 mm, PCD 92 mm
Flange gasket b)	Graphite	Graphite
Switch element	hermetically sealed SPDT microswitch, silver contacts	SPDT microswitch, gold plated contacts
Switch rating	250 VAC, 5A / 30 VDC, 5A	for intrinsically safe circuits
Safety classification	Ex ed IIC T6...T5 Ga/Gb	Ex ia IIC T6 Ga/Gb
Certificate	EPS 12 ATEX 1430 X c)	EPS 12 ATEX 1430 X
Enclosure	IP66/IP67	IP66/IP67
Safety integrity level	SIL1 (SIL3 capable)	SIL1 (SIL 3 capable)
SIL2 Version:	ZTDKK8E28 01 07 As type above but with: Dual SPDT microswitches	TDBB8E28 01 07 As type above but with: Dual SPDT microswitches

- a) Correlation of operating and ambient temperature see diagram page 8 and 9
- b) Option: PTFE gasket (E52) e.g. ZTDK8E28 01**E52** 07
- c) Option: IECEx (5), TR CU (1) approval, e.g. for IECEx: ZTDK**5E28** 011Z 76

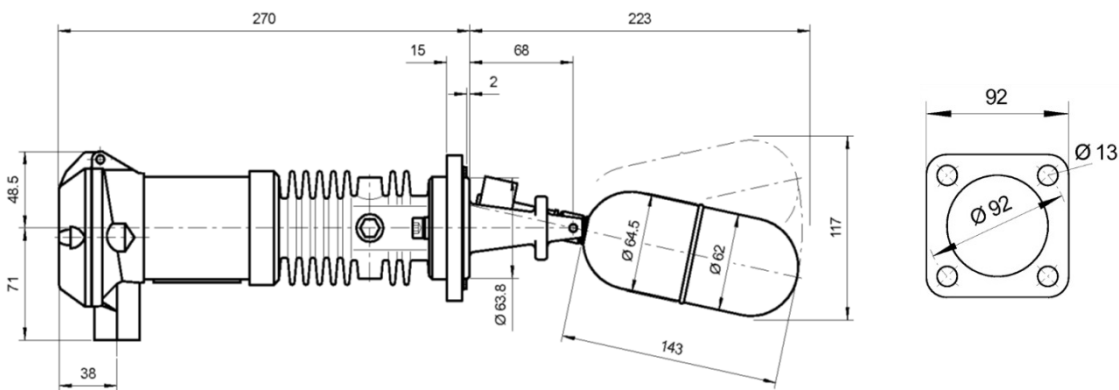

3

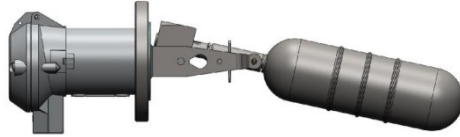

Type	ZK8E28 011ZE217 76	DB8E28 011ZE217 76
	Ex ed (ATEX) , min. density: 0.32 kg/dm ³ , min. operating temperature: -30°C	Ex ia (ATEX) , min. density: 0.32 kg/dm ³ , min. operating temperature: -40°C
Nominal pressure	PN 25 acc. to DIN	PN 25 acc. to DIN
Operating temperature a)	-30°C to +145°C	-40°C to +200°C
Ambient temperature a)	-45°C to +80°C	-40°C to +120°C
Density of liquid	min. 0.32 kg/dm ³	min. 0.32 kg/dm ³
Operating differential	12 mm, fixed	12 mm, fixed
Wetside / flange material	stainless steel (CrNiMo/316 equiv.)	stainless steel (CrNiMo/316 equiv.)
Housing material	seawater resistant die cast aluminium	seawater resistant die cast aluminium
Housing gasket	Silicon O-Rings (E28)	Silicon O-Rings (E28)
Flange dimensions	ø118 mm, PCD 92 mm	ø118 mm, PCD 92 mm
Flange gasket b)	Graphite (E217)	Graphite (E217)
Switch element	hermetically sealed SPDT microswitch, silver contacts	SPDT microswitch, gold plated contacts
Switch rating	250 VAC, 5A / 30 VDC, 5A	for intrinsically safe circuits
Safety classification	Ex ed IIC T6...T5 Ga/Gb	Ex ia IIC T6 Ga/Gb
Certificate	EPS 12 ATEX 1430 X c)	EPS 12 ATEX 1430 X
Enclosure	IP66/IP67	IP66/IP67
Safety integrity level	SIL1 (SIL3 capable)	SIL1 (SIL3 capable)
SIL2 Version:	ZKK8E28 011ZE217 76 As type above but with: Dual SPDT microswitches	DBB8E28 011ZE217 76 As type above but with: Dual SPDT microswitches

- a) Correlation of operating and ambient temperature see diagram page 8 and 9
- b) Option: PTFE gasket (E52), e.g. ZK8E28 011ZE**E52** 76
- c) Option: IECEx (5), TR CU (1) approval, e.g. for IECEx: ZK**5**E28 011ZE217 76

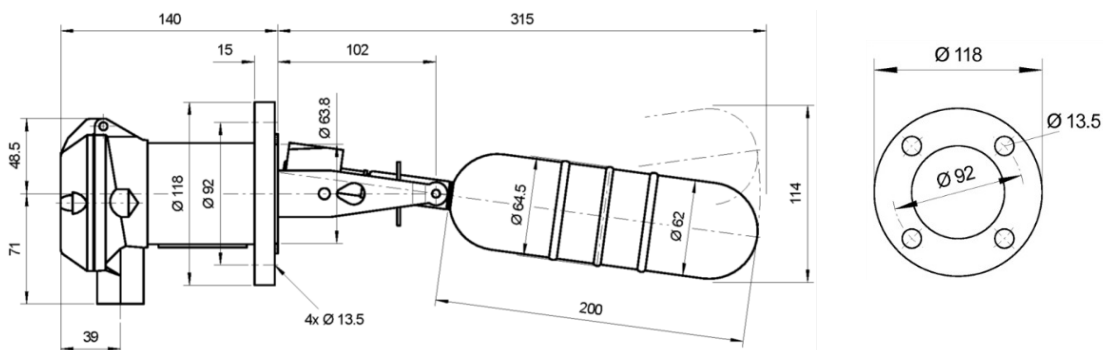

4



Type	ZK8E28 01E217 07	DB8E28 01E217 07
	Ex ed (ATEX) , min. density: 0.44 kg/dm ³ , min. operating temperature: -30°C	Ex ia (ATEX) , min. density: 0.44 kg/dm ³ , min. operating temperature: -40°C
Nominal pressure	PN 25 acc. to DIN	PN 25 acc. to DIN
Operating temperature a)	-30°C to +145°C	-40°C to +200°C
Ambient temperature a)	-45°C to +80°C	-40°C to +120°C
Density of liquid	min. 0.44 kg/dm ³	min. 0.44 kg/dm ³
Operating differential	12 mm, fixed	12 mm, fixed
Wetside / flange material	stainless steel (CrNiMo/316 equiv.)	stainless steel (CrNiMo/316 equiv.)
Housing material	seawater resistant die cast aluminium	seawater resistant die cast aluminium
Housing gasket	Silicon O-Rings (E28)	Silicon O-Rings (E28)
Flange dimensions	square 92 x 92 mm, PCD 92 mm	square 92 x 92 mm, PCD 92 mm
Flange gasket b)	Graphite (E217)	Graphite (E217)
Switch element	hermetically sealed SPDT microswitch, silver contacts	SPDT microswitch, gold plated contacts
Switch rating	250 VAC, 5A / 30 VDC, 5A	for intrinsically safe circuits
Safety classification	Ex ed IIC T6...T5 Ga/Gb	Ex ia IIC T6 Ga/Gb
Certificate	EPS 12 ATEX 1430 X c)	EPS 12 ATEX 1430 X
Enclosure	IP66/IP67	IP66/IP67
Safety integrity level	SIL1 (SIL3 capable)	SIL1 (SIL3 capable)
SIL2 Version:	ZKK8E28 01E217 07 As type above but with: Dual SPDT microswitches	DBB8E28 01E217 07 As type above but with: Dual SPDT microswitches

- a) Correlation of operating and ambient temperature see diagram page 8 and 9
- b) Option: PTFE gasket (E52), e.g. ZK8E28 01E52 07
- c) Option: IECEx (5), TR CU (1) approval, e.g. for IECEx: ZK5E28 01E217 07

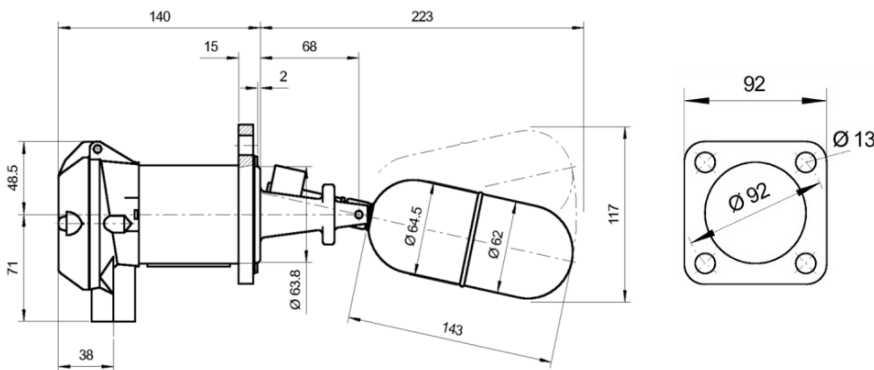

Correlation of operating and ambient temperature of switch types ZK... (Ex ed)

Operating temperature [°C]

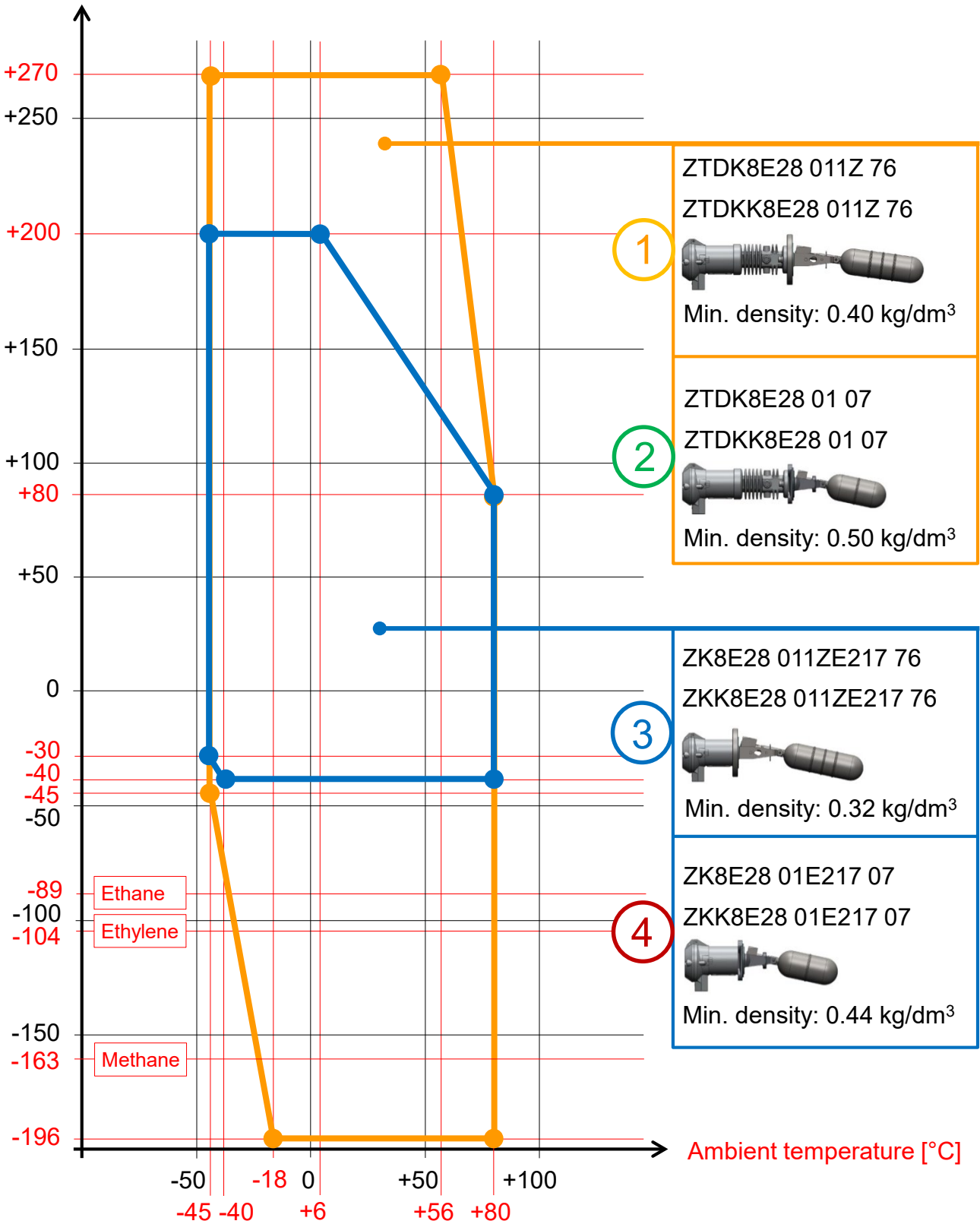

Correlation of operating and ambient temperature of switch types BE... (Ex ia)

Operating temperature [°C]

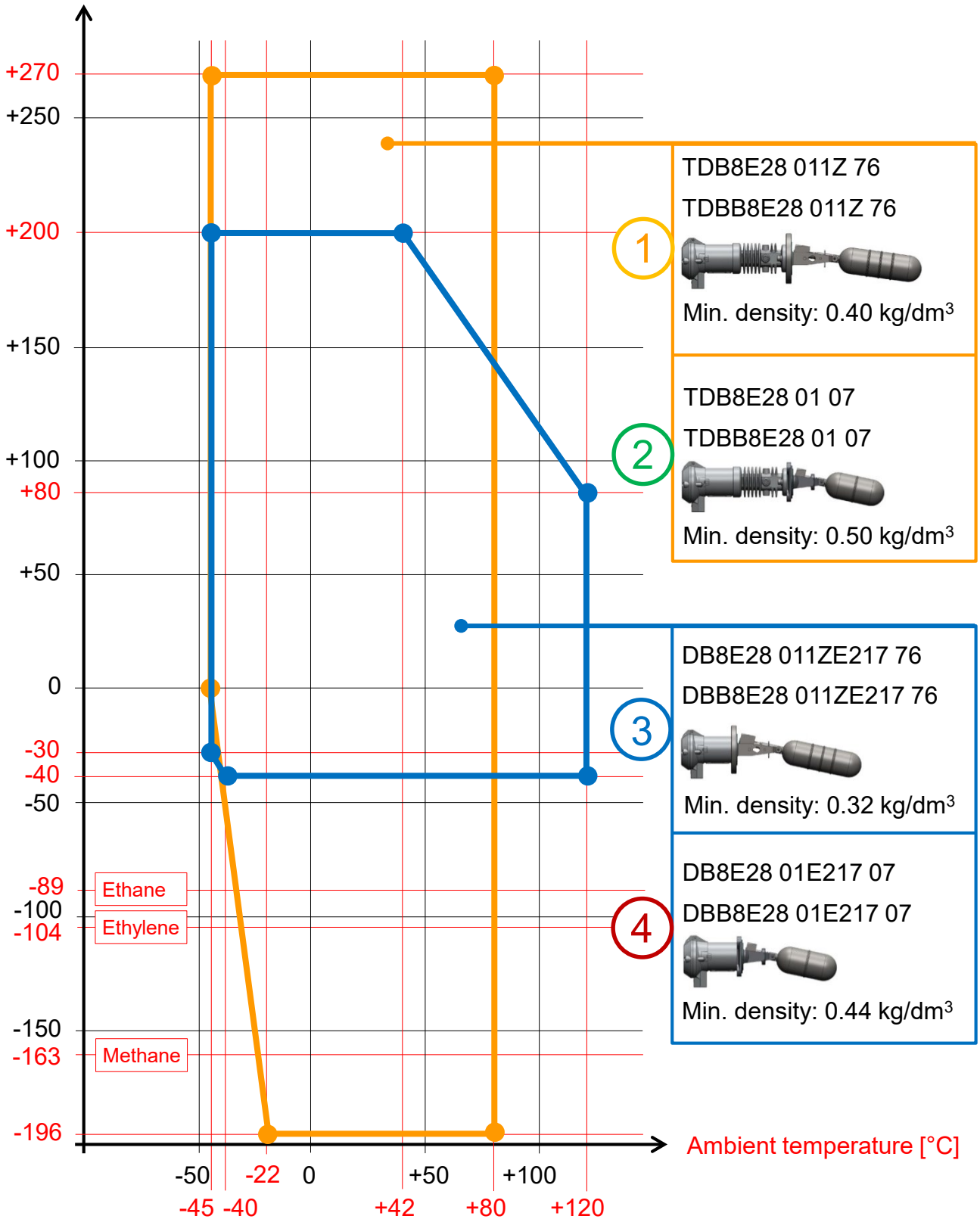

Minimum density and temperature range

	Switch type	Ex	min. density kg/dm ³	temperature range ambient °C	operating °C
①	ZTDK8E28 011Z 76	ed	0.40	-45 to +80	-196 to +270
	TDB8E28 011Z 76	ia	0.40	-40 to +80	-196 to +270
②	ZTDK8E28 01 07	ed	0.50	-45 to +80	-196 to +270
	TDB8E28 01 07	ia	0.50	-40 to +80	-196 to +270
③	ZK8E28 011ZE217 76	ed	0.32	-45 to +80	-30 to +145
	DB8E28 011ZE217 76	ia	0.32	-40 to +120	-40 to +200
④	ZK8E28 01E217 07	ed	0.44	-45 to +80	-30 to +145
	DB8E28 01E217 07	ia	0.44	-40 to +120	-40 to +200

Liquid gases

Gas	Evaporation temperature at atmospheric pressure	Density (kg/dm ³) at relevant temp.
N-butane	-0.5°C	0.601
Butadiene 1.3	-5.0°C	0.615
Iso-butane	-10.0°C	0.594
VCM Vinyl chloride	-15.0°C	0.911
DME Dimethyl ether	-24.0°C	0.735
Ammonia	-33.6°C	0.682
Propane	-43.8°C	0.581
Propylene	-47.3°C	0.614
Ethane	-88.9°C	0.544
Ethylene	-104.0°C	0.568
Methane	-163.0°C	0.422
	-196.0°C	



Level switch for leakage monitoring with pneumatic test actuator

The level switch can be placed outside of the LNG tanks or within the double hulls.

Type	2DB8E275 01 04G3E276 Ex ia (ATEX), min. density: 0.4 kg/dm ³ min. operating temperature: -30°C
Nominal pressure	PN 16 acc. to DIN
Operating temperature	-30°C to +120°C a)
Ambient temperature	-30°C to +120°C a)
Density of liquid	approx. 0.40 kg/dm ³ , depending on dimensions of A and B
Operating differential	29 mm, fixed
Wetside / flange material	stainless steel (CrNiMo/316 equiv.)
Housing material	seawater resistant die cast aluminium
Flange dimensions	square 92 x 92, PCD 92 mm
Switch element	SPDT microswitch, gold plated contacts
Switch rating	for intrinsically safe circuits
Safety classification	Ex ed IIC T6 Ga/Gb
Certificate	EPS 12 ATEX 1430 X
Enclosure	IP66/IP67 b)
Pneumatic connection	ø6 mm
Air pressure	1 to 10 bar

- a) Note: instruction for air supply (freeze, humidity)
b) Option: IP68 with cable and epoxy filled cable entry

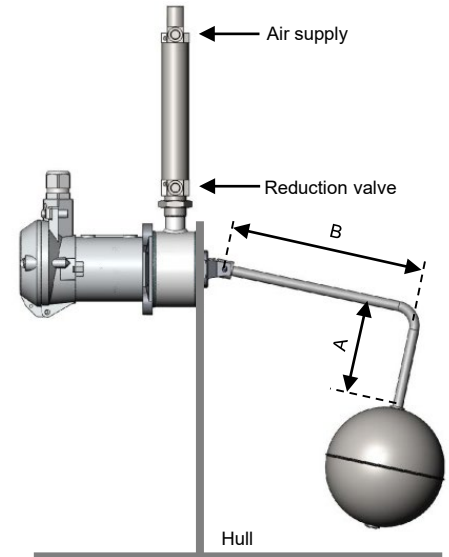

SIL2 Version: **2DBB8E275 01 04G3E276**
As type above but with:
Dual SPDT microswitches

Type **2DB8E275 01 04G2**
As type above but with:
- other float module
- min. density of 0.70 kg/dm³, if
A = 400 mm, B = 300 mm

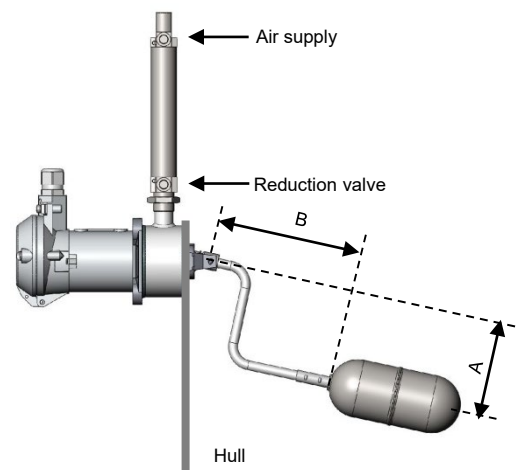

Accessories: Counterflanges and test actuators

Counterflanges

The simplest method of installing any Trimod^BBesta level switch of the Standard range is to use our weld-on counterflanges in carbon steel (-10 to +300°C) or stainless steel (-196 to +400°C)

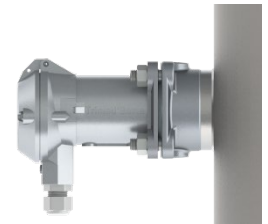

Standard Version

Type	length (V)	material
2829.1	38 mm	CS: P250GH
2831.3	38 mm	SS: 1.4404
2829.1V80	80 mm	CS: P250GH
2831.3V80	80 mm	SS: 1.4404

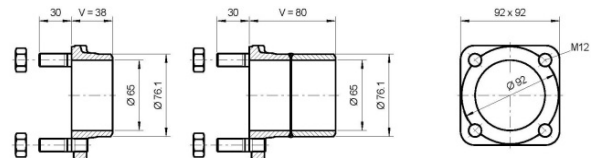

Version for use with test actuator (type 2382, 2383, 2384E217)

Type	length (V)	material
2829.2	38 mm	CS: P250GH
2831.4	38 mm	SS: 1.4404
2829.2V80	80 mm	CS: P250GH
2831.4V80	80 mm	SS: 1.4404

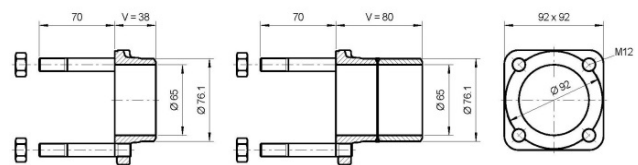

Test actuators

The test actuators can be used, if the tank is already equipped with a Trimod^BBesta counterflange. Operating pressure: -1 to 25 bar



Type	material	O-ring	Flat gasket	Temperature range
2382	1.4305/1.4404	FPM	Blue Gard 3000	0°C to +150°C
2383	1.4305/1.4404	EPDM	Blue Gard 3000	-30°C to +150°C
2384E217	1.4305/1.4404	VMQ	Graphite	-60°C to +150°C

O-ring

FPM	Viton
EPDM	Ethylen-Propylen-Dien-Rubber
VMQ	Silicon

Flat gasket

Dimension	ø77/64 x 2
Standard	Blue Gard 3000 and Graphite
Option	PTFE

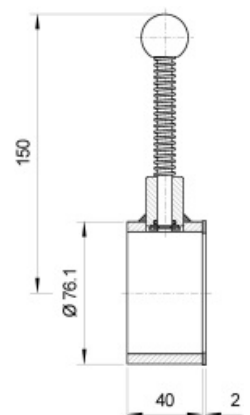

Switch Elements; Microswitches



B-Series

Microswitch with gold plated contacts

For switch types B, DB, TDB, XB, etc. (SPDT)
BB, DBB, TDBB, XBB, etc. (Dual SPDT)

Electrical rating Suitable for very low ratings e.g. EEx i circuits (intrinsically safe)



ZK-Series

Flameproof microswitch (Ex d II C) with silver contacts

For switch types ZK, ZTDK, etc. (SPDT)
ZKK, ZTDKK, etc. (Dual SPDT)

Electrical rating 250 VDC, 5 A / 30 VDC, 5 A

Switch Modules; SPDT and Dual SPDT

B - Version

1 Microswitch, SPDT

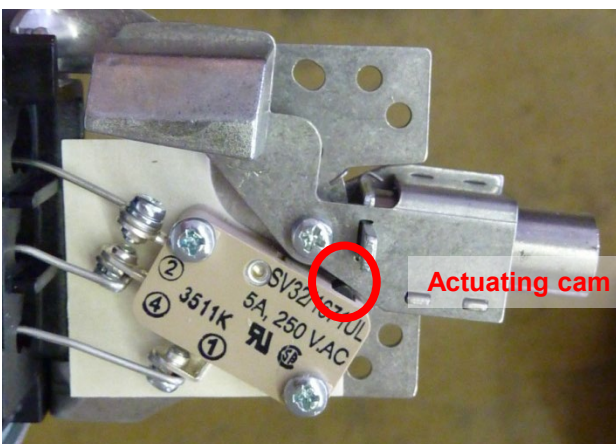

SPDT: Single Pole Double Throw
→ one changeover switch

BB - Version

2 Microswitches, Dual SPDT

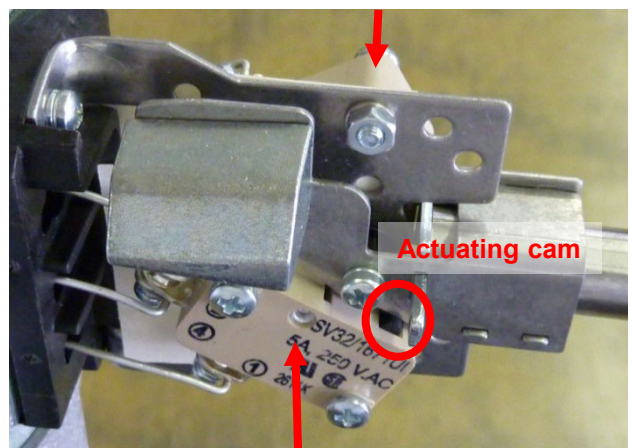

Dual SPDT: Two Single Pole Double Throw
→ two changeover switches

IP68 Enclosure

With epoxy filled cable entry for maximum safety.
 Ambient temperature: -30°C to +80°C
 Cable: min. -30°C

Type example:

Type: **U3**B8 01 07

Type: **ZU3**KE28 01 07

Type: **XU3**BE28 01 07

3 → with 3 meter cable.

Any other length is also available

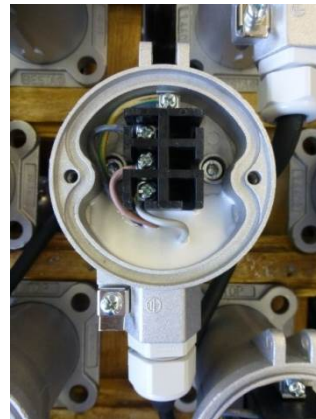

U.B.. and ZU.. housing

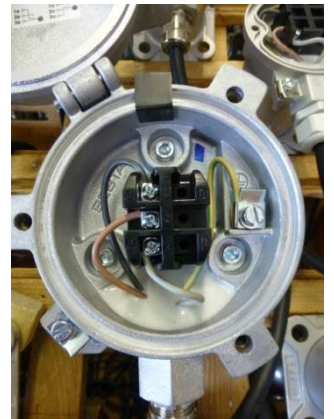

XU.. housing



Ergonomical and handy design

Captive cover and screws - no lost parts

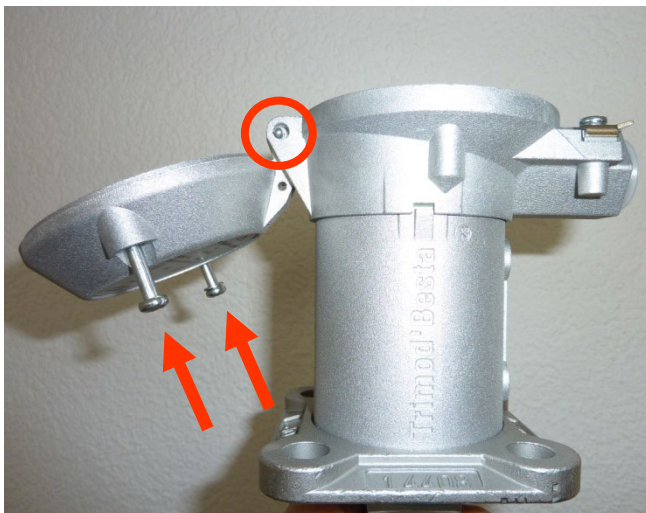

Self-lifting terminals

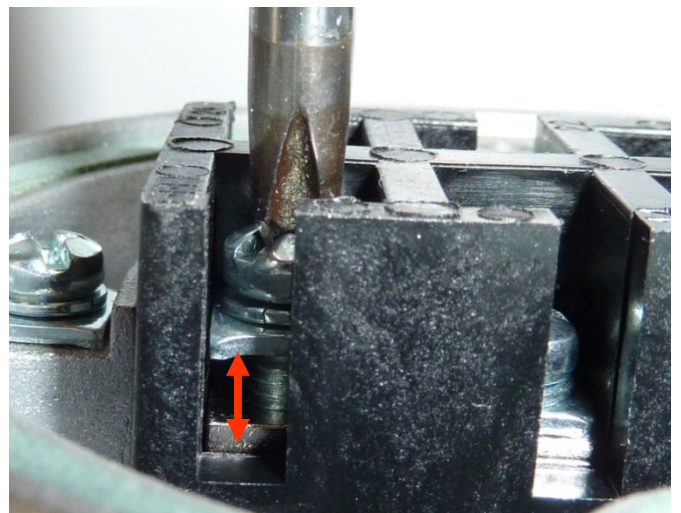

Fast and perfect cable connection

Simple cable routing, due to spacious connection room and large cable entry.

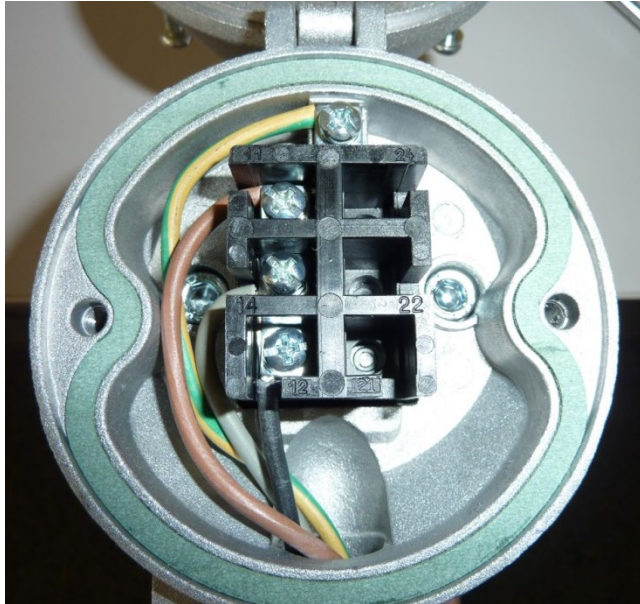

Guided cable by 270 degree to guarantee 100% perfect cable connection.

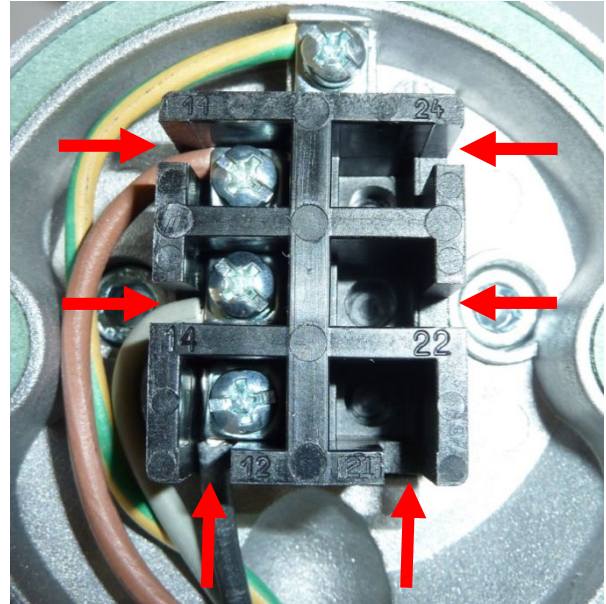

Safe and quick

High sparking distance on terminal block to prevent from short circuit.

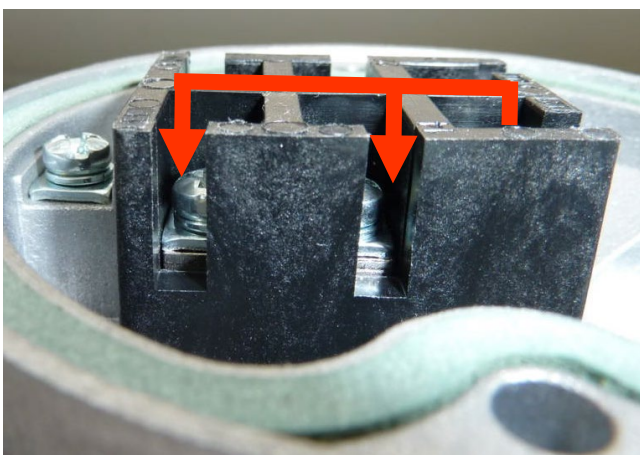

The switch module can be disassembled with just two screws.

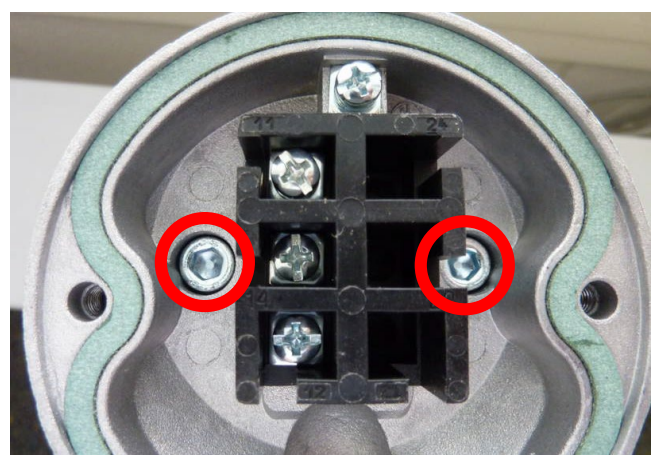

Typical level switches for general applications in shipbuilding

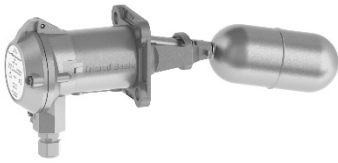

General purpose level switch for high and low alarm



Pneumatic level switch (ON/OFF) and controller (proportional output signal: 0.2 to 1 bar or 7 to 15 psi)



Level switch for high/low alarm and for pump control. Max. operational differential 2840 mm

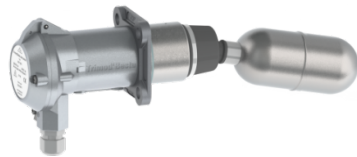

Level switch for grey and black-water application



Level switch for interface application e.g. water/oil control



IP68 level switch with cable and epoxy filled cable entry for submersible application

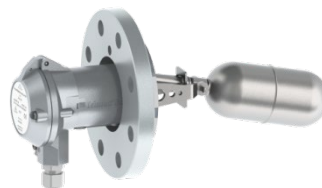

Level switch with DIN or ANSI flange for boiler control up to PN320/cl.2500



Top mounting level switch for high alarm



Level switch for pump control with adjustable control range, max. 557 mm



Level switch with Ex de housing for high/low alarm

Trimod^BBesta

Level measurement A brand of Bachofen AG
www.trimodbesta.com

Bachofen AG
Ackerstrasse 42
8610 Uster
Switzerland

Phone: +41 44 944 11 11
Fax: +41 44 944 11 11
info@trimodbesta.com
www.trimodbesta.com

Authorized Distributor



SMERI srl
Via Mario Idiomi 3/13 - 20057 Assago MI
Telefono: +39 02 5398941
www.smeri.com