

## INSTRUCTION MANUAL

"Intelligent" Differential pressure transmitter

## SERIES DP-4000

## PROFIBUS PA

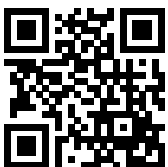
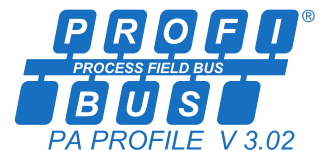

• Warning •

Read the recommendations and warnings in this manual before the instrument is installed. For personal safety, optimal use and maintenance of the Series DP-4000, these instructions should be studied carefully.

Manufactured by:

 **KLAY-INSTRUMENTS B.V.**  
[www.klay.nl](http://www.klay.nl)

Nijverheidsweg 5  
P.O. Box 13  
Tel: +31-521-591550  
Fax: +31 -521-592046

7991 CZ DWINGELOO  
7990 AA DWINGELOO  
The Netherlands  
E-Mail: [info@klay.nl](mailto:info@klay.nl)

## CONTENT

<b>1.</b>	<b>INTRODUCTION</b> .....	<b>3</b>
1.1	DESCRIPTION SERIES DP-4000.....	3
1.2	DESCRIPTION SERIES DP-4000 with separate diaphragm seals.....	3
1.3	DRAIN AND VENT VALVES.....	3
<b>2.</b>	<b>DIMENSIONAL DRAWINGS</b> .....	<b>4</b>
<b>3.</b>	<b>APPLICATIONS</b> .....	<b>5</b>
<b>3.</b>	<b>INSTALLING THE TRANSMITTER</b> .....	<b>6</b>
3.1	TRANSMITTER HOUSING (Fully rotatable).....	6
3.2	MANIFOLDS (Optional).....	6
3.3	MOUNTING POSITION.....	6
3.4	MOUNTING POSITION EFFECT.....	6
3.5	PROCESS CONNECTION.....	6
3.6	CALIBRATION.....	6
3.7	PROFIBUS PA CABLE.....	7
3.8	CONNECTION TERMINAL.....	7
3.9	GROUNDING.....	8
3.10	CABLE SHIELDING.....	8
3.11	TERMINATION.....	8
<b>4.</b>	<b>REMAINING</b> .....	<b>8</b>
4.1	CE/EMC-RULES.....	8
4.2	TRACEBILITY / YEAR OF MANUFACTURING.....	8
<b>5.</b>	<b>GRAPHIC DISPLAY AND NAVIGATION BUTTON</b> .....	<b>9</b>
5.2	SUMMARY PROGRAMMING POINTS.....	10
<b>6.</b>	<b>EXPLANATION PROGRAMMING POINTS</b> .....	<b>11</b>
6.1	ZERO ADJUSTMENT.....	11
6.2	SPAN ADJUSTMENT.....	11
6.3	CANCEL MOUNTING POSITION EFFECT.....	12
6.4	DISPLAY SETTING OF UNITS.....	12
6.5	OUTPUT SELECTION.....	12
6.6	DAMPING ADJUSTMENT.....	12
6.7	LANGUAGE.....	13
6.8	DEVICE SETUP.....	13
6.9	READOUT.....	14
6.10	TANK LINEARIZATION.....	15
6.11	INFORMATION.....	23
6.12	CALIBRATE.....	23
6.13	PA ADDRESS.....	24
6.14	TRANSFER FUNCTION.....	24
<b>7.</b>	<b>PROFIBUS® PA</b> .....	<b>26</b>
7.1	PA INTERFACE.....	26
7.2	IDENT NUMBER.....	32
7.3	GSD FILES.....	32
7.4	ENGINEERING UNITS.....	33
7.5	PROFIBUS ADDRESS.....	33
7.2	ROTATABLE DISPLAY.....	34
<b>8.</b>	<b>SPECIFICATIONS</b> .....	<b>35</b>
<b>9.</b>	<b>PRECAUTIONS AND WARNINGS</b> .....	<b>36</b>

## 1. INTRODUCTION

The Series DP-4000 is a **high-end** pressure, differential pressure and flow transmitter based upon a piezoresistive silicon sensor, with a very high burst pressure. The sensor element is mounted in a stainless steel body.

Pressure on the sensor element creates a very small deflection of the silicon substrate and bridge network. The resulting strain in the silicon resistors causes a change in the bridge resistance that is proportional to the pressure/differential pressure applied. The transmitter electronics detects this change in bridge resistance and converts it into a measuring value. The amplifier system is based on a single microprocessor, which ensures a perfect linearity in the output, all within an accuracy of 0.075 % or 0.065 % (option).

### 1.1 DESCRIPTION SERIES DP-4000

The Series DP-4000 is specially designed as a differential pressure transmitter. The wetted parts are standard made of AISI 316L, other diaphragm materials are available, like Hastelloy C and Tantalum. The process connections are standard fitted with ¼" NPT female thread. Oval flanges can be provide as an option for ½" NPT (f) process connections. All process connections meet the requirements of IEC 61518.

All transmitters are **fully temperature compensated**, which means that various process temperatures have nearly no effect on the accuracy of the output signal. When a failure occurs, the transmitter is repairable. However, for optimum accuracy the transmitter has to be send back to the factory.

### 1.2 DESCRIPTION SERIES DP-4000 with separate diaphragm seals

The DP-4000 is also available with separate diaphragm seals. Standard the wetted parts are made of AISI 316L, other materials like Hastelloy C are available as an option.

### 1.3 DRAIN AND VENT VALVES

As standard the DP-4000 is supplied with two drain valves. They can be screwed from the DP-4000 body to drain or vent the process. These valves must be kept clean. In case the drain valves are not used closing/stopping bolts must be used.

## 2. DIMENSIONAL DRAWINGS

### DP-4000

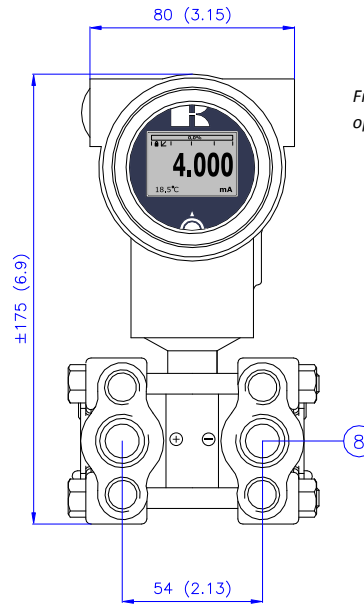
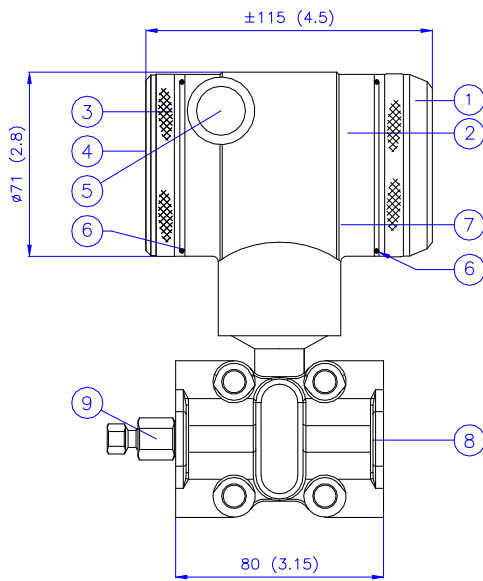

Description	Material
① Cover	SS 304
② Display with navigation button	
③ Cover	SS 304
④ Venting	PA
⑤ M20 x 1,5 cable entry (without gland) *	

Description	Material
⑥ O-Ring	EPDM
⑦ Electronic housing	SS 304
⑧ Body with process connection: 1/4 – 18 NPT f	SS 316
⑨ Vent valve	SS 316

### DP-4000 Mounting Bracket

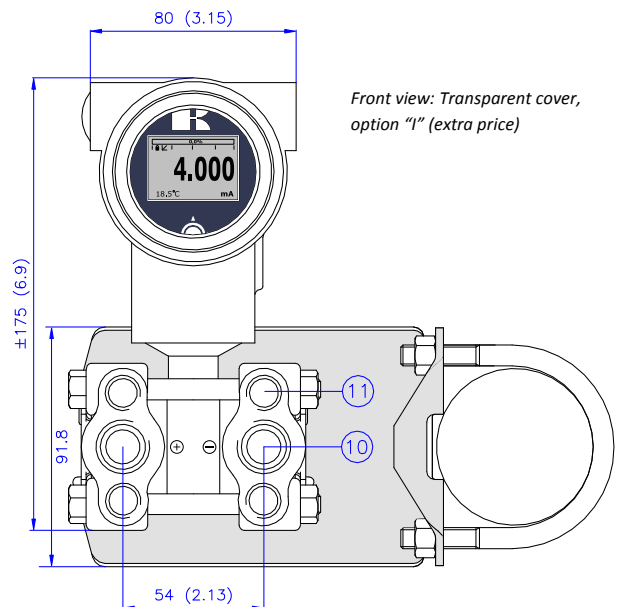
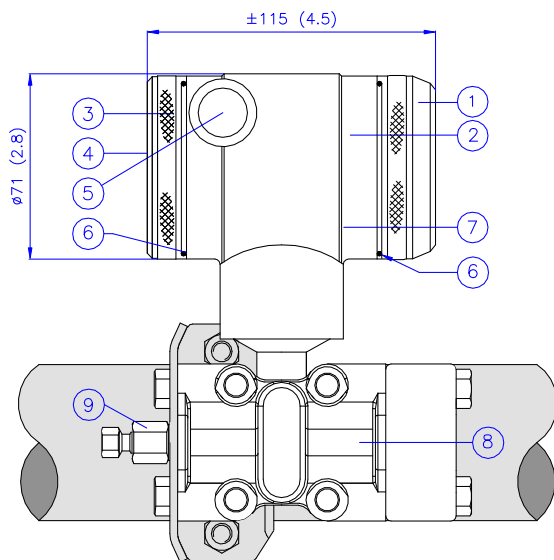

Description	Material
① Cover	SS 304
② Display with navigation button	
③ Cover with venting	SS 304
④ Venting	PA
⑤ M20 x 1,5 cable entry (without gland) *	
⑥ O-Ring	EPDM

Description	Material
⑦ Electronic housing	SS 304
⑧ Body with process connection: 1/4 – 18 NPT f	SS 316
⑨ Vent valve	SS 316
⑩ Process Connection	SS 316
⑪ 7/16 -UNF Internal thread	SS 316

## DP-4000 Wall mounting

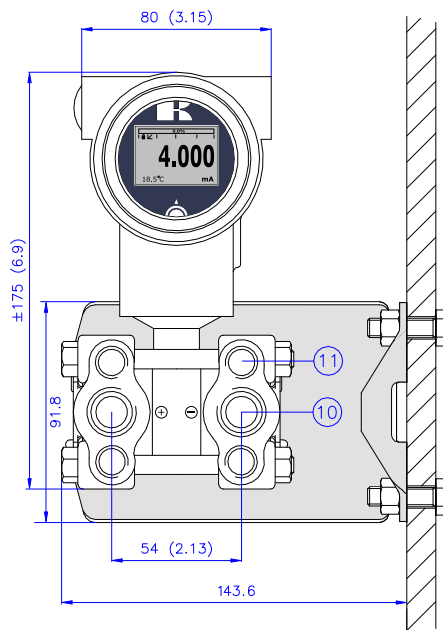

\* As standard the DP-4000 will be supplied with **two** cable entries M20 x 1,5. A cable gland can be supplied on request (extra costs).

### 3. APPLICATIONS

The Series DP-4000 can be used in wide variety of applications such as differential pressure, level and flow measurement.

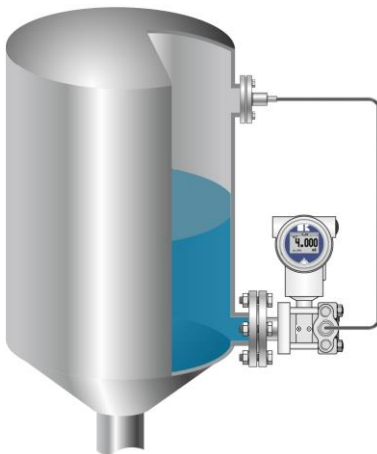

*Differential pressure measurement with flanged connection and chemical seal.*

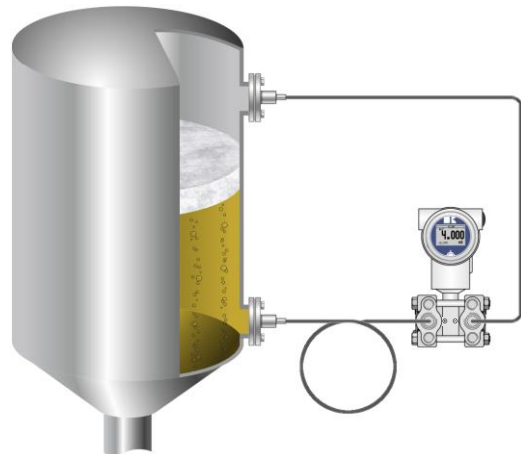

*Differential pressure measurement with chemical seals.*

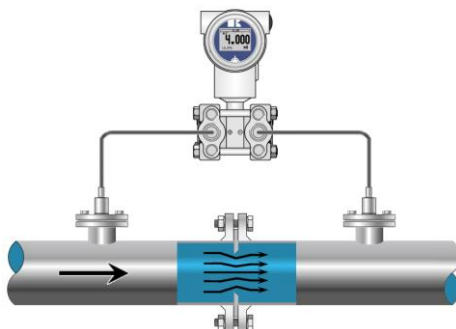

**√(SQUARE ROOT)**

*Flow measurement, for example:  
Orifice flanges, Pitot tubes and Venturi tubes.*

### 3. INSTALLING THE TRANSMITTER

The Diaphragm, Flange or separate diaphragm seals of the transmitter are protected with a special protection cap. It is advisable to only remove this protection until installation takes place. **Do not damage the diaphragm, capillaries or any part of the process connection. Do not dismantle the process connection (Sensor body).**

#### 3.1 TRANSMITTER HOUSING (Fully rotatable)

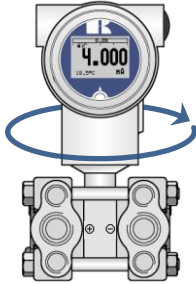

The transmitter housing can be fully rotated both ways 360° degrees. Untighten the hexagon screw  on the outside of the enclosure. Rotate the transmitter housing to the right position and fix the position by tightening the hexagon screw on the outside of the enclosure. The construction prevents the housing from being rotated too far. Where necessary the display can also be rotated separately from the transmitter housing to the right position for most optimum readout (§ 7.2 Rotatable display)

#### 3.2 MANIFOLDS (Optional)



The DP-4000 can be supplied with a 3 or 5 way manifold. The manifold separates the transmitter from the actual process. The advantage of a manifold is simple installation and easy maintenance without interrupting the process. This means higher system availability and even simpler commissioning or maintenance purposes. If the manifold is applied the process connection will change from ¼" NPT (f) to ½" NPT (f) thread.

#### 3.3 MOUNTING POSITION

When the transmitter is mounted horizontally, the cable gland must be pointed downwards.

#### 3.4 MOUNTING POSITION EFFECT

All transmitters are calibrated in vertical position (diaphragm points downwards). If the transmitter is mounted in another position, there can be a little zero shift. After installation of the transmitter the zero must be set to 0,000 with **P103** cancel mounting position effect. This will not affect the span.



After installation of the transmitter the zero must **ALWAYS** be set with **P103 Cancel mounting position effect**. This will not affect the span.

#### 3.5 PROCESS CONNECTION

Before mounting the transmitter, be aware of the correct position of the high and low pressure side. The process connection is clearly marked with the symbols + and -.

#### 3.6 CALIBRATION

All transmitters are fully calibrated at the factory, to customer specified range. If the calibration is not specified, the transmitter will be calibrated at the maximum span.

### 3.7 PROFIBUS PA CABLE

Under the cover ③ you will find the terminal board. Special PROFIBUS® cable must be used for proper communication. For further detailed description of cable selection, see "Guidelines for planning and commissioning PROFIBUS DP/PA" and "PROFIBUS PA User and Installation Guideline" both on [www.profibus.com](http://www.profibus.com) and IEC 61158-2 on [www.iec.ch](http://www.iec.ch).



Shielded Profibus cable

The PROFIBUS® standard defines two variations of bus cable: Type A and Type B. However it is recommended to use cable Type A in all new installations. Type A is recommended for high transmission speeds and permits a doubling of the network distance in comparison to Type B.

Type A Technical specification:

- **Impedance:** 35 up to 165 Ohm at frequencies from 3 to 20 Mhz.
- **Cable capacity:** < 30 pF per meter.
- **Core diameter:** > 0,34 mm<sup>2</sup>, corresponds to AWG 22.
- **Cable type:** Twisted pair cable. 1x2 or 2x2 or 1x4 lines.
- **Resistance:** < 110 Ohm per km.
- **Signal damping:** max. 9 dB over total length of line section.
- **Shielding:** CU shielding braid or shielding braid and shielding foil.
- **Max. Bus length:** 200 m at 1500 kbit/s, up to 1,2 km at 93,75 kbit/s. (Extendable by repeaters)

Using other types of cable will result in incorrect and disrupted transmissions in the PROFIBUS® network and is strongly discouraged. Do not run wiring in open trays with power wiring, or near heavy electrical equipment (For example frequency controllers or heavy pumps). To eliminate electromagnetic effects it is highly recommended to use a EMC Cable gland. (Option G73)

### 3.8 CONNECTION TERMINAL

Illustrative side view

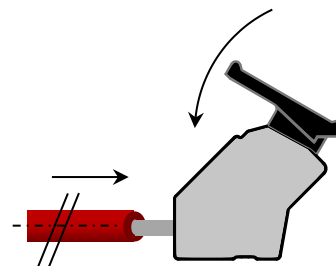
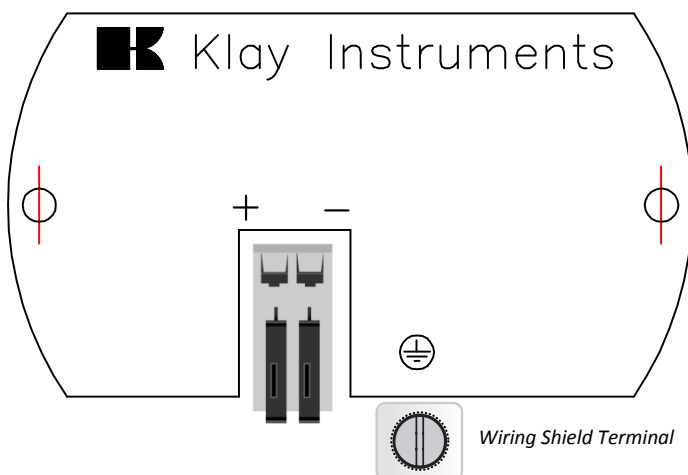

Insert the wires into the connector and push the lever down by hand.

The figure above shows the wiring connection of the transmitter. The 2-wires must be connected to the terminal board. The polarity of the Series DP-4000-PROFIBUS PA is independent and reversing the polarity will not affect the functionality or damage the transmitter. The transmitter automatically detects the polarity of the connected Profibus® cable.

The wiring terminals can be operated without a screwdriver. The opening levers of the terminals can be lifted and pressed down by hand. Lift the opening levers of the terminals and insert the corresponding wires. Press down the levers by hand, the terminal spring will close and the wire is clamped.

### 3.9 GROUNDING

The transmitter must always be connected to ground. In case the process connection is already connected to ground (For example by the tank or pipe line), do not connect the instrument to ground.

### 3.10 CABLE SHIELDING

The cable shield must only be connected at **one** side. Optionally an EMC Cable gland can be provided (Option G73). When a EMC Cable gland is used, the cable shield at the Profibus power supply or installation must be disconnected.



**Please ensure that the instrument is not connected to ground twice. For correct grounding the recommendations of IEC 61158-2 must be followed.**

### 3.11 TERMINATION

Termination of the bus prevents signal reflections on the PROFIBUS® cable. A terminator is a combination of a resistor and a capacitor. Wrong or missing termination results in transmission errors. At the end of each cable trunk a terminator must be used. In common a terminator is integrated in a segment coupler. When there is no integrated terminator present in the trunk, a separate terminator must be used.

## 4. REMAINING

### 4.1 CE / EMC-RULES

All Klay transmitters are manufactured in accordance with the RFI / EMC directives and comply with the CE standard. All transmitters are fitted with RFI filters, which provide optimum, trouble-free operation. Our products are in conformity with EMC-Directive 2004/108/EC based on test results using harmonized standards.

### 4.2 TRACEABILITY / YEAR OF MANUFACTURING

The year of manufacturing of the transmitter can be traced as follows: take the first three numbers from the serial number that is engraved in the transmitter and add 1600 to it.

Example: Serial Number 41602123. The year of manufacturing is  $1600 + 416 = 2016$ .



## 5. GRAPHIC DISPLAY AND NAVIGATION BUTTON

The DP-4000 has a multifunctional display where different values can be displayed simultaneously. The display is equipped with a backlight. The entire menu is controlled by a navigation button. The navigation button has the following possibilities of movement: up, down, left, and right. The navigation button needs to be pushed when conformation or saving is needed.

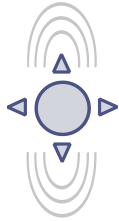

Move the navigation button up or down to browse through various menus. These movements can be distinct in choices of: program points, navigation through menu's and increase or decrease measurement value's.

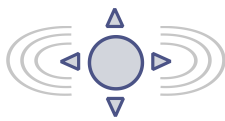

Move the navigation button left or right to navigate horizontally through the menu or positions on the display.

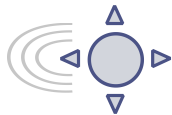

**It is always possible to return to the previous menu.** Move the navigation button to the left to return to the previous menu.

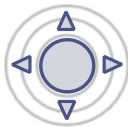

By pushing the navigation button each choice will be **confirmed** or a setting will be **saved**.

Figure 1. Display Series DP-4000, fully rotatable (360°)



### 5.1 GRAPHIC DISPLAY READOUT

When the transmitter is powered, a startup screen with the name of the transmitter (Series 4000) and the software version appear for a few seconds. The **PROFIBUS® address** is shown at the bottom of the display. As standard (Unconfigured) the address is **126**. This address is used for configuration and commissioning purposes only. The address can be changed with Program point P113 or a Profibus Master device (Only Class 2).

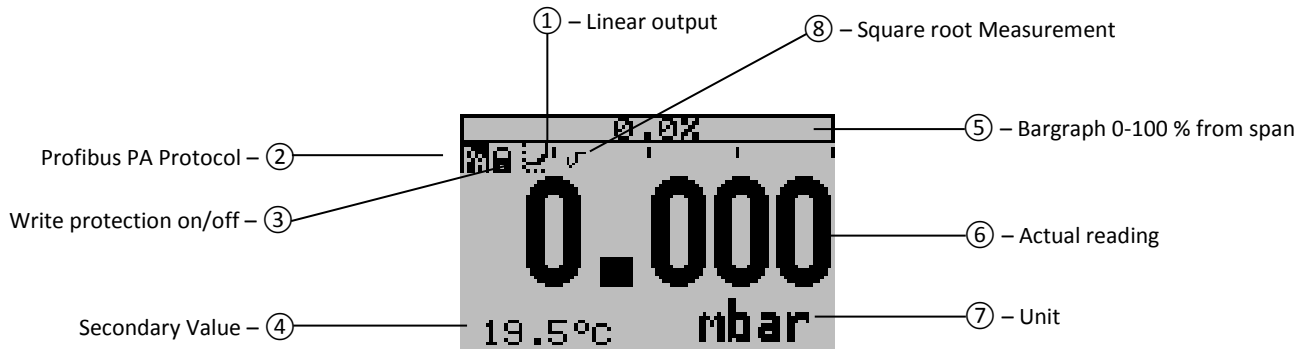

#### EXPLANATION OF SYMBOLS:

- 1. – **Linear output:** Displays when any form of linearization is applied. A straight line means no linearization is applied. When a linearization is applied a curve will be displayed.
- 2. – **Profibus PA:** Profibus PA Protocol applied
- 3. – **Write protection on/off:** Displays if protection against adjustments and configuration is on or off
- 4. – **Secondary Value:** Displays a secondary chosen measurement.
- 5. – **Bargraph 0 - 100 % from span:** Displays the percentage of the measured span.
- 6. – **Actual reading:** Displays the actual reading, percentage or a selectable unit.
- 7. – **Unit:** Displays the selected unit.
- 8. – **Square root:** Displays when a flow measurement is enabled.

### 5.2 SUMMARY PROGRAMMING POINTS

PROGRAM POINT	NAME	FUNCTION
P100	Menu-Exit menu	Start and exit
P101	ZERO value	Zero adjustment (ZERO) with or without test pressure
P102	SPAN value	Span adjustment (SPAN) with or without test pressure
P103	MOUNT correction	Cancel mounting position effect
P104	UNITS	Selection of engineering unit to be displayed
P105	REVERSE Out	Scaling 0 - 100 % or 100 - 0 %
P106	DAMPING	Adjustable damping (0,00 till 25,00 s)
P107	LANGUAGE	Language choice between: English, Dutch, German, Russian, Polish and French.
P108	DEVICE SETUP	Configuration of: Protection, Alarm, Backlight, Temperature, Secondary value, Set time and HART Version.
P109	READOUT	Readout options on display: Current, unit, percentage and temperature
P110	TANK LINEARIZATION	Configuration for tank linearization
P111	INFORMATION	Contact information of Klay Instruments, settings, and software revision
P112	CALIBRATE	Only available for the manufacturer
P113	PA ADDRESS	Adjustable PA Address
P114	TRANSFER FUNCTION	Flow configuration: Linear and (√) Square Root



Configuring the transmitter local and remote simultaneously will cause transmission errors and must be prevented.

## 6. EXPLANATION PROGRAMMING POINTS

### P101 Zero value

#### 6.1 ZERO ADJUSTMENT

The transmitter is set to 0 mbar at atmospheric pressure.

The **ZERO** can be adjusted at a lower or higher point. This will be explained step by step by an example.

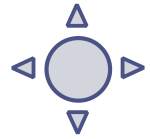

Example: Increase ZERO till 100 mbar.

1. The measuring unit of the transmitter is set to mbar. If not this can be selected by choosing the right measuring unit in program point **P104 – UNITS (paragraph 6.4)**
2. Navigate to program point **P101 - ZERO Value**, and push the navigation button to enter the menu.
3. Two choices appear on the screen: **set manual** and **use process**  
**Set manual** = Configuration without test pressure.  
**Use process** = Configuration with applied pressure.
4. Choose **set manual**, +000.0 (mbar) will appear on the display.
5. Increase this value with the navigation button to 100 mbar, push to confirm, and select **SAVE** to save the setting.
6. The transmitter will return to the home screen. The measurement value at atmospheric pressure is now -100 mbar. At an applied pressure of 100 mbar the transmitter will display 0 mbar.

The menu zero adjustment also has the choice of “**use process**”. The transmitter can be adjusted to zero in a real process situation. When chosen, the transmitter will measure the pressure in an actual process. This measurement will be used as the zero value.

1. Navigate to program point **P101**, and push the button to enter the menu.
2. Choose “**use process**”, and push to confirm. The transmitter will display the actual measured value.
3. Push the navigation button to confirm, and select **SAVE** to save the setting.
4. The transmitter will return to the main menu.

The ZERO will automatically be set to 0.000 when enabling the Square Root function. After enabling the Square Root function the ZERO (Program point P101) cannot be configured.

### P102 Span value

#### 6.2 SPAN ADJUSTMENT

This setting can be used to adjust the range (SPAN) according to an entered value or adjusted with or without test pressure. The maximum pressure which can be measured is the measurement at **ZERO (P101)** + the entered value **SPAN (P102)**. If the **ZERO (P101)** is increased then the maximum measured value will automatically be set higher at same rate like the zero. This will be explained step by step by an example.

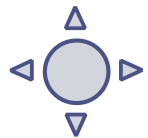

1. Example: Measurement range 100 – 2000 mbar
2. The **span** must be set at 1900 mbar
3. The zero was set in the previous menu (**P101**) at 100 mbar.
4. Navigate to program point **P102 - SPAN Value**, and push the navigation button to enter the menu.
5. Two choices appear on the screen: **Set manual** and **Use process**
6. Choose **Set manual**, a value will appear on the screen. (Depending on the chosen transmitter range.)
7. Adjust the **SPAN** with the navigation button to 1900 mbar. and select **SAVE** to save the setting
8. The transmitter will return to the home screen.

The menu span adjustment also has the choice of **Use process**. The transmitter can be adjusted to the span in a real process situation. When chosen, the transmitter will measure the pressure in an actual process. This measurement will be used as the span value.

1. Navigate to program point **P102**, and push the button to enter the menu.
2. Choose **Use process**, and push to confirm. The transmitter will display the actual measured value.
3. Push the navigation button to confirm, and select **SAVE** to save the setting.
4. The transmitter will return to the main menu.

## P103 Mount corr.

### 6.3 CANCEL MOUNTING POSITION EFFECT

All transmitters are vertically calibrated. If the transmitter is installed horizontally, the transmitter has a small *mounting position* effect on the zero. The pressure value displayed, will be for example 0,002 mbar instead of 0,000 mbar. This effect can be neutralized within this menu.

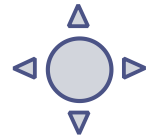

1. Navigate to program point **P103 – MOUNT corr.**, and push the navigation button to enter the menu.
2. Two choices appear on the screen: **Set** and **Reset**

Choosing **Set** will adjust the zero to 0,000 mbar in the mounting position when applicable.

- Select **Set**, and push the button to confirm.
- The Save  icon will be displayed to indicate that the setting is saved.
- The transmitter will return to the main menu.

Choosing **Reset** will put the transmitter back to factory setting. (vertical adjustment)

- Select **Reset**, and push the button to confirm, the setting will be put back to factory setting. The Save  icon will be displayed to indicate that the setting is saved.
- The transmitter will return to the main menu.





**CAUTION: Do not apply pressure while executing "Cancel mounting position effect"**

## P104 Units

### 6.4 DISPLAY SETTING OF UNITS

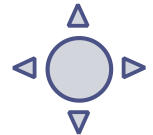
Various engineering units can be displayed on the display.  
Factory setting = mbar



1. Navigate to program point **P104 – UNIT**, and push the navigation button.
2. Several engineering units can be selected. Each selected engineering unit is automatically converted to the correct value of the corresponding unit.
3. Navigate through this menu and choose the required unit, push to confirm.
4. The Save  icon will be displayed to indicate that the setting is saved.
5. The transmitter will return to the main menu, the measured reading will be displayed in the chosen unit in the home screen.



**CAUTION: The selected pressure unit is only visible on the display, if UNITS is chosen in program point P109 – Readout.**

## P105 Reverse mA

### 6.5 OUTPUT SELECTION

The scaling (only in percentage) can be set to 0 - 100 % and reversed 100 - 0 %. This will not affect the measuring value.

The transmitter is standard set to 0%.

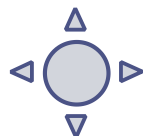

1. Navigate to program point **P105 – Reverse out**, and push the navigation button.
2. Two choices appear on the screen: **0 - 100 %** and **100 - 0 %**.
3. Make a choice and push to confirm.
4. The Save  icon will be displayed to indicate that the setting is saved.
5. The transmitter will return to the main menu.
6. The Analog Input Block parameters needs to be adjusted accordingly.

## P106 Damping

### 6.6 DAMPING ADJUSTMENT

The transmitter has an adjustable damping between 0,00 to 25,00 seconds.  
Factory setting = 0,00 seconds

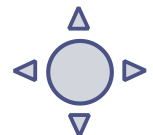

1. Navigate to program point **P106 – DAMPING**, and push the navigation button.
2. Two choices appear on the screen: **Set** and **Reset**

### 3. Make a choice and push to confirm.

Choosing **Set** allows a value to be set between 0,00 and 25,00 seconds.

- Select **Set**, and push the button to confirm.
- Adjust the damping with the navigation button, push to confirm.
- The **Save**  icon will be displayed to indicate that the setting is saved.
- The transmitter will return to the main menu.

Choosing **Reset** will put the setting back to factory setting (0,0 seconds)

- Select **Reset**, and push the button to confirm.
- The **Save**  icon will be displayed to indicate that the setting is saved, the setting will be put back to factory setting 0,00 s.
- The transmitter will return to the main menu.

## P107 Languages

### 6.7 LANGUAGE

In this menu the preferred menu language can be selected.

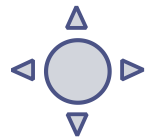

1. Navigate to program point **P107 - LANGUAGE**, and push the navigation button to enter the menu.
2. Seven choices appear on the screen: **English, Dutch, Spanish, German, Russian, Polish and French**.
3. Make a choice and push to confirm.
4. The **Save**  icon will be displayed to indicate that the setting is saved.
5. The transmitter will return to the main menu.

## P108 Device setup

### 6.8 DEVICE SETUP

In this menu, several operational settings can be made for the transmitter and the display.

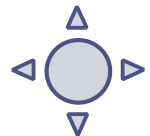

1. Navigate to program point **P108 – Device Setup**, and push the navigation button to enter the menu.
2. Six choices appear on the screen: **Protection - Backlight - Temp units - Temp min/max - Sec. Value** and **PA OUT\_SCALE**.  
Choose the desired option and push to confirm.
3. Below are the choices displayed. They can be selected and configured using the navigation button.
  - **Protection:** Open and Protected: Local protection for adjusting settings locally on the transmitter. When exceeding limits, a warning symbol will display on the screen.
  - **Backlight:** Choice between: **On, Sleep mode** (Turn off backlight after 5 minutes) and **Off**.
  - **Temp units:** Choice between: **Celsius** and **Fahrenheit**.
  - **Temp min/max:** Two choices appear on the screen: **Readout** and **Reset**  
By choosing **Readout** the last measured minimum and maximum temperature values of process and ambient appear. For the process temperature, a new value is stored in a change of temperature more than 2 °C. For the ambient temperature this is 5° C. By choosing **Reset** the previous stored values will be deleted.
  - **Sec. Value:** Three choices appear on the screen for the secondary readout on the main screen: **Unit, Rate** and **Temperature**.
  - **PA OUT\_SCALE:** In this menu scaling options for the Analog Input block (Profibus Output) can be configured locally on the transmitter. Two choices appear on the screen: **Set 1:1** and **Set manual**.
    - With option **Set 1:1** a scaling can be set with the following menu choices: **EU100, EU0** and **Unit**. As standard the values are the same as the last saved Zero, Span and engineering unit (P109 must be set to **unit** or **percentage**).  
Select **EU100** to enter a value for the 100% scaling point.  
Select **EU0** to enter a value for the 0% scaling point.  
Select **Unit** to enter the engineering unit code.

- With option **Set manual** the current scaling configuration (Profibus output) is shown. Set manual should only be used for units not supported by the DP-4000, or when a different scaling than the local readout is needed on the Profibus output.

The engineering units can be found in the attachment of this manual or in the digital version on [www.klay.nl](http://www.klay.nl) under section downloads.

Profibus scaling will be explained step by step by the following examples:

**Scaling Example - Pressure:**

- Configure the Zero - P101 (If necessary)
- Configure the Span - P102 (If necessary)
- Select *mbar* in program point P104 (or any other pressure unit)
- Select *Unit* in program point P109
- Navigate to program point P108 and select **PA OUT\_SCALE**
- Configure the scale with **Set 1:1**, navigate to save, to save the setting.
- The transmitter will restart to load the new scale.

**Scaling Example - Percentage:**

- Configure the Zero - P101 (If necessary)
- Configure the Span - P102 (If necessary)
- Select *Percentage* in program point P109
- Navigate to program point P108 and select **PA OUT\_SCALE**
- Configure the scale with **Set 1:1**, navigate to save, to save the setting.
- The transmitter will restart to load the new scale.

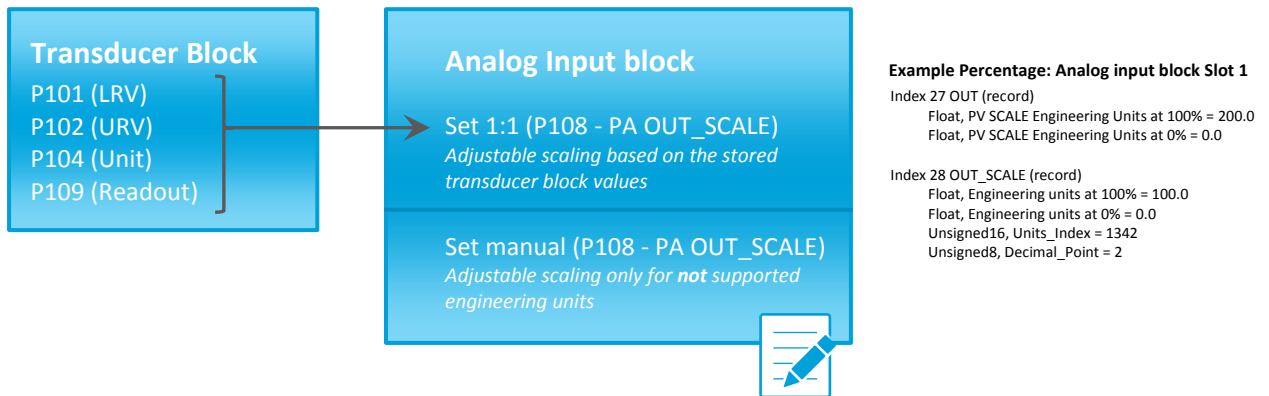

**CAUTION:** Do not change the Zero, Span, Unit or Readout (P109) after configuring the Profibus Out scaling, as described above. Changing will result in invalid Profibus communication.

**P109  
Readout**

**6.9 READOUT**

In this menu, the readout on the display is determined. This is the type of measurement that appears on the home screen. Factory Setting = Unit

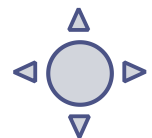

1. Navigate **P109 – READOUT**, and push the navigation button to enter the menu.
2. Eight choices appear on the screen:
  - Unit** = Pressure unit as chosen in **P104**
  - Percentage** = 0 - 100%
  - Temperature** = Actual sensor temperature (°C or F) \*
  - Hectoliter** = Number of hectoliters (only possible in combination with linearization P110)
  - Cubic meter** = Number of cubic meters (in combination with linearization P110)

**Liter** = Number of liters (only possible in combination with linearization P110)

**Kilogram** = Number of kilograms (only possible in combination with linearization P110)

After selecting this readout the **Specific Gravity** of the medium (**SG = g/cm<sup>3</sup>**) must be entered with a value between 0.2 and 4.0 g/cm<sup>3</sup>. The specific gravity will appear on the home screen (g/cm<sup>3</sup>) under the primary selected readout. This readout will be indicated as a linear measurement, and displayed by the symbol on the home screen.

**Tons** = Number of tons (only possible in combination with linearization P110)

After selecting this readout the **Specific Gravity** of the medium (**SG = g/cm<sup>3</sup>**) must be entered with a value between 0.2 and 4.0 g/cm<sup>3</sup>. This readout will be indicated as a linear measurement, and displayed by the symbol on the home screen. The specific gravity will appear on the home screen (g/cm<sup>3</sup>) under the primary selected readout.

3. Navigate to the desired choice, confirm the selection by pushing the navigation button. The Save icon will be displayed to indicate that the setting is saved.
4. The transmitter will return to the main menu.
5. The Analog Input Block parameters needs to adjusted accordingly.

\*(Indication of process temperature, accuracy depending on sensor position)



*For measuring weight (Kg and Tons), a reliable accuracy cannot be guaranteed, the DP-4000 pressure transmitter cannot compensate for Specific Gravity changes or any thermal increase or decrease.*

## P110 Tank Lin.

### 6.10 TANK LINEARIZATION

In this menu, various tank linearization's can be selected.

Factory setting = No linearization The volume as a measured value will be displayed on the home screen. (set in **P104**) The values (configured in the following settings) must be in meters. Only for local use, not compatible with Profibus.

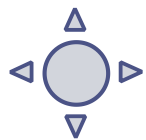

1. Navigate to program point **P110 – TANK LIN**, and push the navigation button to enter the menu. Six choices appear on the screen:
  - No Lin** = No linearization
  - Hor. Tank** = Linearization setting for a horizontal tank: cylindrical and elliptic
  - Vert. Cone** = Linearization setting for a vertical tank with a conical bottom.
  - Vert. Sphere** = Linearization setting for a vertical tank with a spherical bottom.
  - Vert. Trunc** = Linearization setting for a vertical tank with a truncated bottom.
  - Free lin** = Free linearization setting, adjustable in 100 free programmable points.

#### LINEARIZATION DISABLE

With the choice **No. Lin.** an existing linearization can be turned off and can be identified by the symbol on the home screen:

Linearization can be recognized by the following symbol on the home screen:

1. Select **No Lin.** and confirm this with the button.
2. The Save icon will be displayed to indicate that the setting is saved.

The following pages describe the setting for each type of linearization.



**LINEARIZATION HORIZONTAL TANK (WITH FLAT END)**

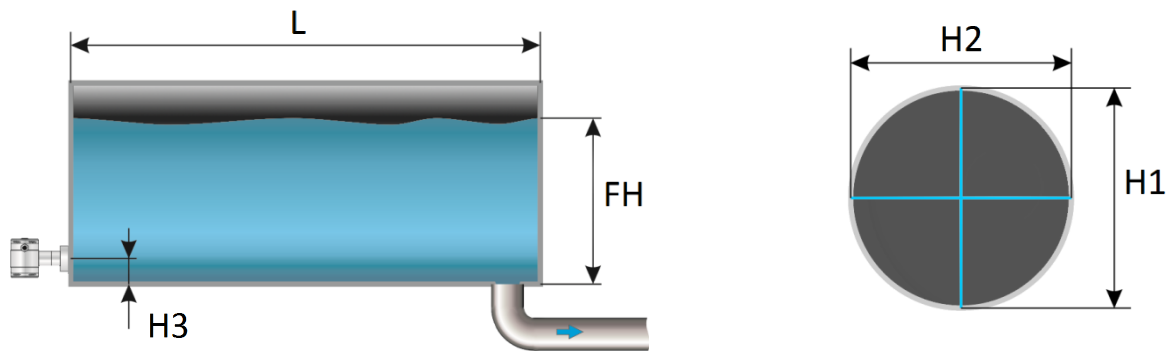

1. Navigate to **Hor. Tank.** with the navigation button, and push to confirm.
2. Two choices appear on the screen: **Input** and **Simulate**
3. Select **Input**, and push to confirm.
4. Six choices appear on the screen:

Display	Drawing	Explanation
Length	<b>L</b>	The length of the tank
Height 1	<b>H1</b>	The height of the tank
Height 2	<b>H2</b>	The diameter of the tank (with a cylindrical tank, this is equal to the height of the tank)
Height 3	<b>H3</b>	The height till the topside of the diaphragm (or weld-on nipple)
Height 4	<b>H4</b>	Value must be 0
Fill Height	<b>FH</b>	The maximum percentage of filling of the tank

5. Fill in each value except Height 4, and confirm each selection with the control button. The values must be entered in meters.
6. Select **SAVE** to save the setting.
7. The transmitter will return to the main menu.

**SIMULATION**

After linearization is entered and stored, it is possible to perform a simulation based on the entered value's. Based on the value entered in mWc, the transmitter will display the number of hectoliters (on the basis of the specified linearization values).

1. Navigate to program point **P110 – TANK LIN**, and push the navigation button to enter the menu.
2. Navigate to **Hor. Tank.** with the navigation button, and push to confirm.
3. Two choices appear on the screen: **Input** and **Simulate**
4. Select **Simulate**, and push to confirm.
5. Fill in the desired value based on mWc, the number of hectoliters change directly with a change in the value mWc.



**LINEARIZATION HORIZONTAL TANK WITH A PARABOLIC END (CYLINDRICAL OR ELLIPTIC)**

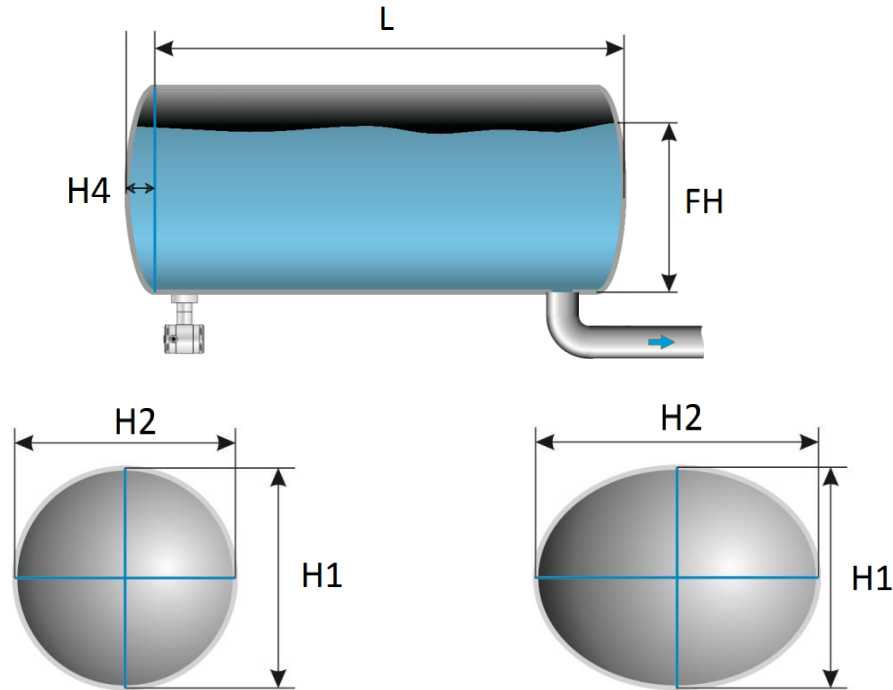

1. Navigate to **Hor. Tank.** with the navigation button, and push to confirm.
2. Two choices appear on the screen: **Input** and **Simulate**
3. Select **Input**, and push to confirm.
4. Six choices appear on the screen:

Display	Drawing	Explanation
Length	<b>L</b>	The length of the tank
Height 1	<b>H1</b>	The height of the tank
Height 2	<b>H2</b>	The diameter of the tank (with a cylindrical tank, this is equal to the height of the tank)
Height 3	<b>H3</b>	The height till the topside of the diaphragm (or weld-on nipple)
Height 4	<b>H4</b>	The length of 1 parabolic end of the cylinder
Fill Height	<b>FH</b>	The maximum percentage of filling of the tank

5. Fill in each value, and confirm with the navigation button. **The entered value's must be in meters.**
6. Select **SAVE** to save the setting.
7. The transmitter will return to the main menu.

**SIMULATION**

After linearization is entered and stored, it is possible to perform a simulation based on the entered value's. Based on the value entered in mWc, the transmitter will display the number of hectoliters (on the basis of the specified linearization values).

1. Navigate to program point **P110 – TANK LIN**, and push the navigation button to enter the menu.
2. Navigate to **Hor. Tank.** with the navigation button, and push to confirm.
3. Two choices appear on the screen: **Input** and **Simulate**
4. Select **Simulate**, and push to confirm.
5. Fill in the desired value based on mWc, the number of hectoliters change directly with a change in the value mWc.

**LINEARIZATION VERTICAL TANK WITH A CONICAL BOTTOM**

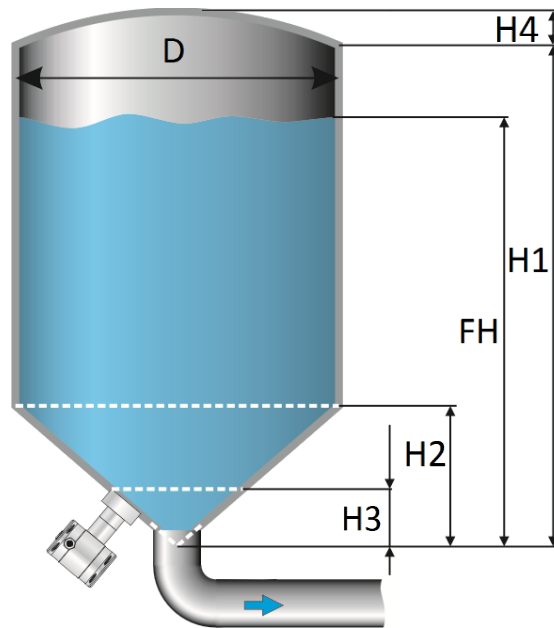

1. Navigate to **Vert. Sphere.** with the navigation button, and push to confirm.
2. Two choices appear on the screen: **Input** and **Simulate**
3. Select **Input**, and push to confirm.
4. Six choices appear on the screen:

Display	Drawing	Explanation
Height1	<b>H1</b>	The height of the tank
Diameter	<b>D</b>	The diameter of the tank
Height 2	<b>H2</b>	the height of the cone
Height 3	<b>H3</b>	The height till the topside of the diaphragm
Height 4	<b>H4</b>	The height of the parabolic tank roof
Fill Height	<b>FH</b>	The maximum percentage of filling of the tank

5. Fill in each value, and confirm with the navigation button. **The entered value's must be in meters.**
6. Select **SAVE** to save the setting.
7. The transmitter will return to the main menu.

**SIMULATION**

After linearization is entered and stored, it is possible to perform a simulation based on the entered value's. Based on the value entered in mWc, the transmitter will display the number of hectoliters (on the basis of the specified linearization values).

1. Navigate to program point **P110 – TANK LIN**, and push the navigation button to enter the menu.
2. Navigate to **Vert. Sphere.** with the navigation button, and push to confirm.
3. Two choices appear on the screen: **Input** and **Simulate**
4. Select **Simulate**, and push to confirm.
5. Fill in the desired value based on mWc, the number of hectoliters change directly with a change in the value mWc.

**LINEARIZATION VERTICAL TANK WITH A SPHERICAL BOTTOM**

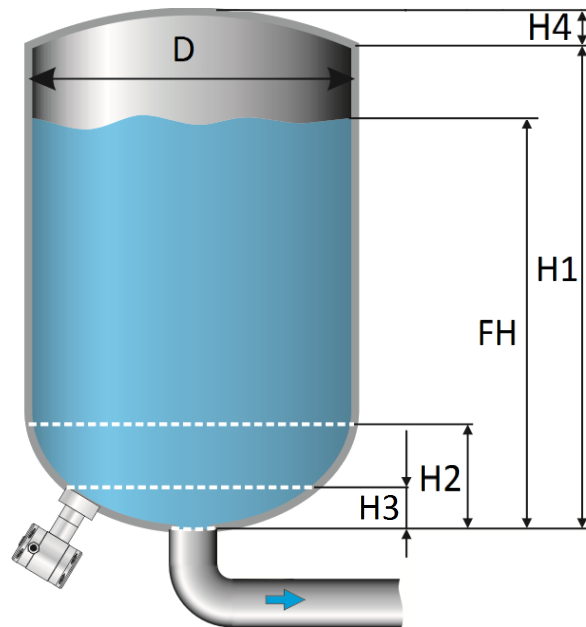

1. Navigate to **Vert. Cone.** with the navigation button, and push to confirm.
2. Two choices appear on the screen: **Input** and **Simulate**
3. Select **Input**, and push to confirm.
4. Six choices appear on the screen:

Display	Drawing	Explanation
Height1	<b>H1</b>	The height of the tank
Diameter	<b>D</b>	The diameter of the tank
Height 2	<b>H2</b>	the height of the spherical bottom
Height 3	<b>H3</b>	The height till the topside of the diaphragm
Height 4	<b>H4</b>	The height of the parabolic tank roof
Fill Height	<b>FH</b>	The maximum percentage of filling of the tank

5. Fill in each value, and confirm with the navigation button. **The entered value's must be in meters.**
6. Select **SAVE** to save the setting.
7. The transmitter will return to the main menu.

**SIMULATION**

After linearization is entered and stored, it is possible to perform a simulation based on the entered value's. Based on the value entered in mWc, the transmitter will display the number of hectoliters (on the basis of the specified linearization values).

1. Navigate to program point **P110 – TANK LIN**, and push the navigation button to enter the menu.
2. Navigate to **Vert. Cone.** with the navigation button, and push to confirm.
3. Two choices appear on the screen: **Input** and **Simulate**
4. Select **Simulate**, and push to confirm.
5. Fill in the desired value based on mWc, the number of hectoliters change directly with a change in the value mWc.

**LINEARIZATION VERTICAL TANK WITH A TRUNCATED BOTTOM**

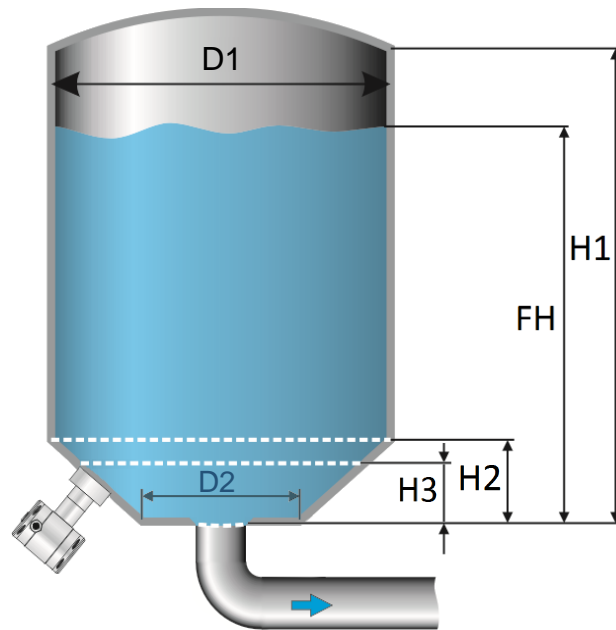

1. Navigate to **Vert. Trunc.** with the navigation button, and push to confirm.
2. Two choices appear on the screen: **Input** and **Simulate**
3. Select **Input**, and push to confirm.
4. Six choices appear on the screen:

Display	Drawing	Explanation
Height1	H1	The height of the tank
Diameter 1	D1	The diameter of the tank
Height 2	H2	the height of the cone
Height 3	H3	The height till the topside of the diaphragm
Diameter 2	D2	The diameter of the truncated bottom
Fill Height	FH	The maximum percentage of filling of the tank

5. Fill in each value, and confirm with the navigation button. **The entered value's must be in meters.**
6. Select **SAVE** to save the setting.
7. The transmitter will return to the main menu

**SIMULATION**

After linearization is entered and stored, it is possible to perform a simulation based on the entered value's. Based on the value entered in mWc, the transmitter will display the number of hectoliters (on the basis of the specified linearization values).

1. Navigate to program point **P110 – TANK LIN**, and push the navigation button to enter the menu.
2. Navigate to **Vert. Trunc.** with the navigation button, and push to confirm.
3. Two choices appear on the screen: **Input** and **Simulate**
4. Select **Simulate**, and push to confirm.
5. Fill in the desired value based on mWc, the number of hectoliters change directly with a change in the value mWc.

## FREE LINEARIZATION

### FREE LINEARIZATION IN PROCESS

1. Navigate to program point **P110 – TANK LIN**, and push to confirm.
2. Navigate to **Free lin.** with the navigation button, and push to confirm.
3. Two choices appear on the screen: **Measured** and **Manual**
4. Select **Measured** to configure a free linearization in a process situation.
5. Two choices appear on the screen: **Input** and **Simulate**
6. Select **Input**, and push to confirm
7. Five choices appear on the screen:

**Clear table:** The previous entered values for linearization will be deleted. It is advisable to use this feature for each time a new linearization is configured.



**All entered values and dimensions of an existing / previous linearization will be erased.**

**Volume units:** Select the preferred unit: Liters, Hectoliters, Kg and Tons (after linearization the unit can be changed and selected in **P109**)

**Height:** The height of the tank can be filled in (highly recommended for an accurate linearization). The transmitter will determine with this height the span. A linearization will be made with the smallest possible deviation. *Factory setting = Saved span in P102.*

**Start Point:** The filling of a tank can be measured up to 70 points. The transmitter must be installed in an actual process to accomplish these measurements. The measuring must take place from low to high. (Filling an empty tank). The actual measuring will be displayed on the screen in percentage (%) for **Xn** (filling) and for **Yn** the measured volume. To enter the next measured point move the navigation button up and enter the values.

**Save:** When all desired measurements are completed and all parameters have been set, the linearization must be saved. Push the navigate button to the left and select **SAVE** to save the linearization. The transmitter will return to the main menu.



### WARNING AND PRECAUTIONS

- When a tank filling (**Xn**) does not reach 100 % of the height of the tank, the transmitter will calculate the remaining part. This calculating method is linear and will only be used for the remaining part up to 100 %.



- It is not advisable to manually adjust the SPAN in program point P102 after a linearization has been configured. If the SPAN is adjusted after a linearization configuration, a warning will appear on the screen when entering P102.
- When the a free linearization is used for measuring weight (Kg and Tons), a reliable accuracy cannot be guaranteed due to external influences such as heat and tank wall expansion. **The change of Specific Gravity due to different temperatures cannot be compensated by the Series 4000 pressure transmitter.**

### SIMULATION

After linearization is entered and saved, it is possible to perform a simulation. (Based on the saved linearization) The transmitter will convert the entered mWc to hectoliters.

## FREE LINEARIZATION MANUALLY

When it's not possible to enter and measure for a linearization in an actual process condition, a free linearization can be configured manually. Known measurements values and volumes must be entered manually in the transmitter.

1. Navigate to program point **P110 – TANK LIN**, and push the navigation button to enter the menu.
2. Navigate to **Free lin.** with the navigation button, and push to confirm.
3. Two choices appear on the screen: **Measured** and **Manual**
4. Select **Manual** to configure a free linearization manually.
5. Two choices appear on the screen: **Input** and **Simulate**
6. Select **Input**, and push to confirm.
7. Five choices appear on the screen:

**Clear table:** The previous entered values for linearization will be deleted. It is advisable to use this feature for each time a new linearization is configured.

 **All entered values and dimensions of an existing / previous linearization will be erased.**

**Volume units:** Select the preferred unit: Liters, Hectoliters, Kg and Tons (after linearization the unit can be changed and selected in **P109**)

**Height:** The height of the tank can be filled in (highly recommended for an accurate linearization). The transmitter will determine with this height the span. A linearization will be made with the smallest possible deviation. *Factory setting = Saved span in P102.*

**Start Point:** The contents of a tank can be configured up to 70 points. The entered value's must be from low to high (Filling an empty tank). The manually entered values will be displayed on the screen in percentage (%) for **Xn** and for **Yn** in Hectoliters. To enter the next measured point move the navigation button up and enter the values.

**Example:** A tank filling must programmed in the transmitter.

- Choose **Clear Table** to remove all possible previous settings.
- Choose the preferred **Volume units**.
- Fill in the **Height** of the tank (highly recommended for an accurate linearization).
- In menu **Start Point** the linearization points can be filled in. In **Xn1** the percentage of the filling must be filled in. In **Yn1** the corresponding volume. After this, there are 69 more linearization points available.
- When all (needed) points are filled in, the linearization must be saved. Push the navigation button to the left and select **SAVE** to save this linearization.

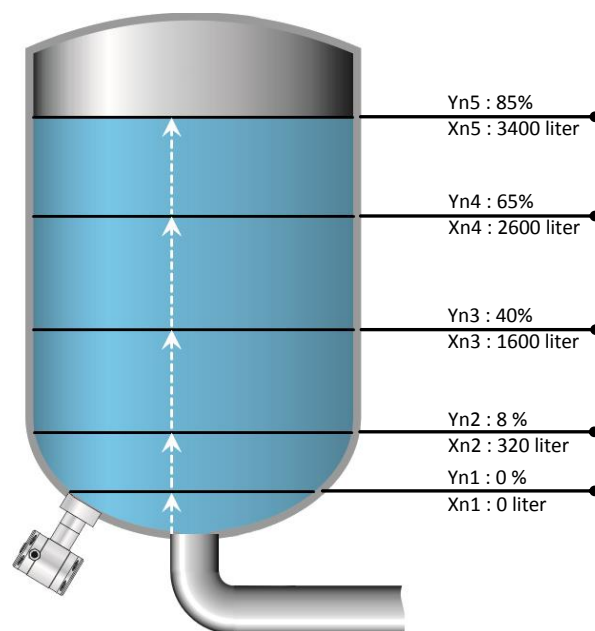

The figure above shows a tank with standard dimensions. Free linearization can be applied on a wide variety of tanks with non-standard dimensions.

**Save:** When all desired measurements are completed and all parameters have been set, the linearization must be saved. Push the navigation button to the left to Exit and select **SAVE** to save the linearization. The transmitter will return to the main menu.

**WARNING AND PRECAUTIONS**

- When a tank filling (Xn) is not configured till 100 %, the transmitter will calculate the remaining part. This calculating method is linear and will only be used for the remaining part up to 100 %.



- It is not advisable to manually adjust the SPAN in program point P102 after a linearization has been configured. If the SPAN is adjusted after a linearization configuration, a warning will appear on the screen when entering P102.
- When the a free linearization is used for measuring weight (Kg and Tons), a reliable accuracy cannot be guaranteed due to external influences such as heat and tank wall expansion. **The change of Specific Gravity due to different temperatures cannot be compensated by the Series 4000 pressure transmitter.**

**SIMULATION**

After linearization is entered and stored, it is possible to perform a simulation. (Based on the stored linearization) The transmitter will convert the entered mWc to hectoliters.

**As an option the DP-4000 can be delivered with option G171. This is a special setting of the software, enabling the display to show a reading in weight units.**

**P111**  
**Information**

**6.11 INFORMATION**

This menu shows a collection of information from the transmitter and contact information from the manufacturer.

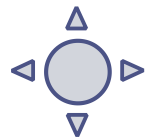

1. Navigate to program point **P111 - Information** and push the navigation button.
2. Push the navigation button up and down to see all of the information
3. Push the button to leave this menu. Below is a representation of this information screen:

```

Klay Instruments
www.klay.nl
+31521591550
Version           -      Software revision
Pa Version        -      3.02
No:               -      Serial number transmitter
Zero              -      Zero (bar)
Span              -      Span (bar)
Damping           -      Damping (in seconds)
Local Prot        -      Protection On or Off
Sec. Value        -      Selected secondary configuration
Backlight         -      Backlight On, Sleep mode or Off
Temp              -      Temperature unit Celsius or Fahrenheit
Print             -      Production code
Supply            -      Production code
Display           -      Production code
    
```

**P112**  
**Calibrate**

**6.12 CALIBRATE**

Only available for the manufacturer.

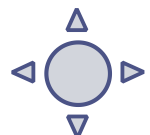

**P113**  
PA Address

**6.13 PA ADDRESS**

In this menu a PA Address from 2 till 126 can be selected.

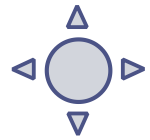

1. Navigate to program point **P113 - PA Address** and push the navigation button to enter the menu.
2. Select the address with the navigation button and push to confirm. Select **SAVE** to save the setting.
3. The following message appear on the display:
4. The transmitter will automatically restart
5. The changed address is displayed in the startup screen.

The transmitter will restart.  
PA Address

**P114**  
Xfer function

**6.14 TRANSFER FUNCTION**

In this menu the characteristics of a flow, volume and differential pressure measuring can be configured. The following options are available:

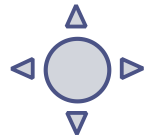

1. Navigate to program point **P114 – Xfer function**, and push the navigation button to enter the menu.
2. Five choices appear on the screen:
  - **Function**
    - **Linear:** The differential pressure measuring between 0 and 100 % of the span.
    - **Square root:** Flow and Volume measuring  
The Zero (**Program point P101**) will automatically be set to 0.000 when enabling the Square Root function. After enabling the Square Root function the Zero (**Program point P101**) cannot be configured.
  - **Cut off:** The Square root function can be enabled with an adjustable cut off value between 0 and 20 %. The cut off adjustment prevents high gain on low values from the Square Root extraction.

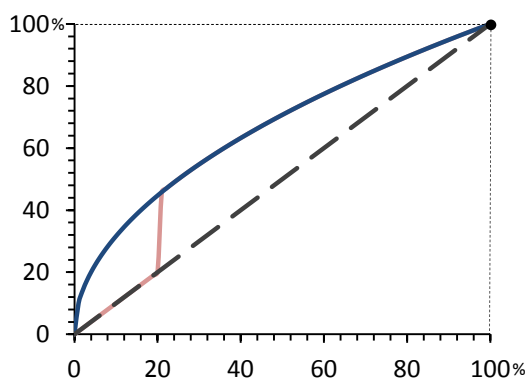

--- Linear output  
— Square root  
— Cut off adjustment

The diagram on the left shows a cut off adjustment at 20 %. From 0 till 20 % the Square root output will use the linear output value instead of the high gain Square Root extraction.

- **Xfer unit:** Multiple engineering units can be selected. Each selected engineering unit is automatically converted to the correct value of the corresponding unit. The following units can be selected:

Volumetric Flow units	
Unit	Description
ft <sup>3</sup> /m	Cubic feet per minute
gal/m	Gallons per minute
l/m	Liters per minute
iGal/m	Imperial gallons per minute
m <sup>3</sup> /h	Cubic meter per hour
gal/s	Gallons per second
Mgal/d	Million gallons per day



l/s	Liters per second
Ml/d	Million liters per day
ft <sup>3</sup> /s	Cubic feet per second
ft <sup>3</sup> /d	Cubic feet per day
m <sup>3</sup> /s	Cubic meters per second
m <sup>3</sup> /d	Cubic meters per day
iGal/h	Imperial gallons per hour
iGal/d	Imperial gallons per day
m <sup>3</sup> /h	Normal cubic meter per hour (MKS System)
l/h	Normal liter per hour (MKS System)
ft <sup>3</sup> /m	Standard cubic feet per minute
ft <sup>3</sup> /h	Cubic feet per hour
m <sup>3</sup> /m	Cubic meters per minute
bbl/s	Barrels per second (1 barrel equals 42 U.S. gallons)
bbl/m	Barrels per minute (1 barrel equals 42 U.S. gallons)
bbl/h	Barrels per hour (1 barrel equals 42 U.S. gallons)
bbl/d	Barrels per day (1 barrel equals 42 U.S. gallons)
gal/h	Gallons per hour
iGal/s	Imperial gallons per second
l/h	Liters per hour
gal/d	Gallons per day

Mass Flow units	
Unit	Description
g/s	Grams per second
g/m	Grams per minute
g/h	Grams per hour
kg/s	Kilograms per second
kg/m	Kilograms per minute
kg/h	Kilograms per hour
kg/d	Kilograms per day
T/m	Metric tons per minute
T/h	Metric tons per hour
T/d	Metric tons per day
lb/s	Pounds per second
lb/m	Pounds per minute
lb/h	Pounds per hour
lb/d	Pounds per day
sT/m	Short tons per minute
sT/h	Short tons per hour
sT/d	Short tons per day
lT/h	Long tons per hour
lT/d	Long tons per day

To display the Square Root output on the display, navigate to program point **P109 – READOUT**, and push to confirm. Navigate to **Xfer function** and push to confirm. The readout on the display will now show the Square Root output, and displayed by the symbol on the home screen.

The scale of the readout can be adjusted between  $\geq 0$  and 100 % by adjusting the scaling in the Lower and Upper range values.

- **Unit LRV:** The Lower Range Value can be adjust between  $\geq 0$  and 100 %. Push the navigation button to enter the menu. A value can be entered. Push to confirm. The Save icon will be displayed to indicate that the setting is saved
- **Unit URV:** The Upper Range Value must be at least  $\geq 10$  % higher than the Lower Range value and can be adjusted up to 100 %. Push the navigation button to enter the menu. A value can be entered. Push to confirm. The Save icon will be displayed to indicate that the setting is saved.

## 7. PROFIBUS® PA

### 7.1 PA INTERFACE

The DP-4000-PROFIBUS PA is developed as a PROFIBUS® Slave device. A slave device is an addressable peripheral device which reads process information and delivers output information to the Master device in the PROFIBUS® system. The Series 4000 is developed for Profibus PA Profile V3.02 and is backwards compatible with Profile version V3.01.

The DP-4000 supports 2 communication layers:

- **DP-V0:** **Cyclic exchange** of process data and exchanging diagnosis functions between master and slaves.
- **DP-V1:** **Acyclic data exchange** and alarm handling between master and slaves for diagnosis, control, monitoring and alarm handling of the slaves in parallel with cyclic data traffic.

The PROFIBUS® PA network is standardized using a block model. The different block types are explained below.

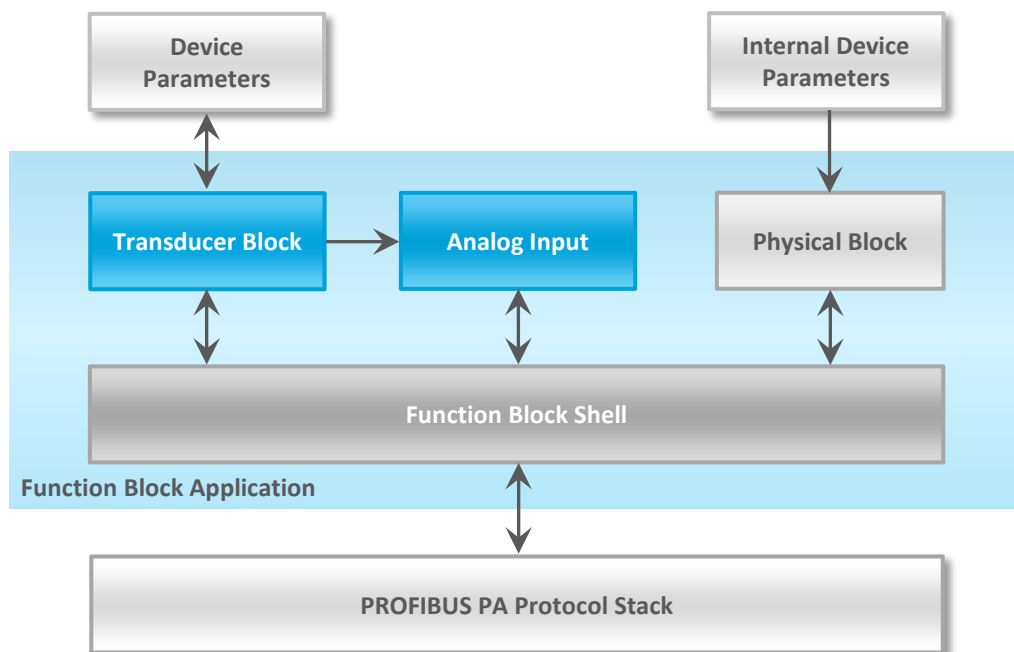

Block Type	Description
Function Block	Control system behavior for example: Analog Input, Analog Output, Discrete Input, Discrete Output and Totalizer.
Transducer Block	Converting mapping between process data and Function Blocks. The Transducer Block is used to perform preprocessing and calibration parameters of device data according to specific device settings. At least one Transducer Block has to be available for a PROFIBUS® PA field device.
Physical Block	Describes the specific data identifying the individual physical device properties such as the device name, manufacturer, and serial number.

### Physical Block Parameters (Slot 0)

In the table below the Physical Block parameters.

Index	Name	Type	Description
16	BLOCK_OBJECT	Record	Block object
	Reserved	Unsigned8	0
	Block_Object	Unsigned8	0x01, physical block
	Parent_Class	Unsigned8	0x01, Transmitter
	Class	Unsigned8	250, not used
	Dev_Rev	Unsigned16	1
	Dev_Rev_Comp	Unsigned16	1
	DD_Revision	Unsigned16	0
	Profile	OctetString(2)	MSB: 0x40 -> Number of the PROFIBUS PA profiles within PI Profile Class 64 LSB: 0x02 -> Class B
	Profile_Revision	Unsigned16	0x302: PA Prfile Revision 3.02
	Execution_Time	Unsigned8	0
	Number_of_Parameters	Unsigned16	29, number of parameters
	Address_of_View_1	Unsigned16	0x00F8, View_1 has an index 248
	Number_of_Views	Unsigned8	1, only one View_1 in Device
17	ST_REV	Unsigned16	ST_REV shall be incremented at least by one if at least one static parameter in the corresponding block has been modified
18	TAG_DESC	OctetString(32)	
19	STRATEGY	Unsigned16	
20	ALERT_KEY	Unsigned8	
21	TARGET_MODE	Unsigned8	Target mode
22	MODE_BLK	Record	
	Actual_mode	Unsigned8	Actual mode
	Permitted_mode	Unsigned8	Permitted mode
	Normal_mode	Unsigned8	Normal mode
23	ALARM_SUM	Record	
	Current	OctetString(2)	Current alarm
	Unacknowledged	OctetString(2)	Unacknowledged alarm
	Unreported	OctetString(2)	Unreported alarm
	Disabled	OctetString(2)	Disabled alarm
24	SOFTWARE_REVISION	VisibleString(16)	Revision-number of the software of the field device
25	HARDWARE_REVISION	VisibleString(16)	Revision-number of the hardware of the field device
26	DEVICE_MAN_ID	Unsigned16	Identification code of the manufacturer of the field device
27	DEVICE_ID	VisibleString(16)	Manufacturer specific identification of the device
28	DEVICE_SER_NUM	VisibleString(16)	Serial number of the field device
29	DIAGNOSIS	OctetString(4)	Detailed information of the device, bitwise coded. More than one message possible at once.
30	DIAGNOSIS_EXT	OctetString(6)	Additional manufacturer-specific information of the device, bitwise coded. More than one message possible at once.
31	DIAGNOSIS_MASK	OctetString(4)	Definition of supported DIAGNOSIS information-bits (0: not supported, 1: supported)
32	DIAGNOSIS_MASK_EXT	OctetString(6)	Definition of supported DIAGNOSIS_EXTENSION information-bits (0: not supported, 1: supported)
33	DEVICE_CERTIFICATION	VisibleString(32)	Certifications of the field device, e.g. EX certification
34	WRITE_LOCKING	Unsigned16	Software write protection
35	FACTORY_RESET	Unsigned16	Parameter for the device resetting
36	DESCRIPTOR	OctetString(32)	

37	DEVICE_MESSAGE	OctetString(32)	
38	DEVICE_INSTAL_DATE	OctetString(16)	
39	NULL_PARAM		Optional parameter LOCAL_OP_ENA isn't implemented
40	IDENT_NUMBER_SELECT		
41	NULL_PARAM		Optional parameter HW_WRITE_PROTECTION isn't implemented
42	FEATURE	Record	Indicates optional features implemented in the device and the status of these features which indicates if the feature is supported or not supported.
	Supported	OctetString(4)	Supported features
	Enabled	OctetString(4)	Enabled features
43	COND_STATUS_DIAG	Unsigned8	Indicates the mode of a device that can be configured for status and diagnostic behavior
44	DIAG_EVENT_SWITCH	Record	Indicates / controls the reaction of the device on device specific diagnostic events if FEATURE.Enabled.Condensed_Status = 1
	Diag_Status_Link	Unsigned8-Array(48)	Array of switches for device specific diagnostic events. Mapping to diagnosis bit and status code
	Slot	Unsigned8	Slot of the continuation of Diag_Event_Switches. Points to the next Diag_Event_Switch structure
	Index	Unsigned8	Index (absolute) of the continuation of Diag_Event_Switches. Points to the next Diag_Event_Switch structure.

**Transducer Block Parameters (Slot 5)**

In the table below the Transducer Block is shown with the specific Device Configuration parameters. Index parameters 25, 27, 43, 44, 45, 53 and 54 can only be configured when transmitter is set to **Out of Service** (OOS). The transducer block can be set to Out of Service in index number 21. After configuring the transducer block, index number 21 must be set to **AUTO**.

Index	Name	Type	Description
16	BLOCK_OBJECT	Record	Block object
	Reserved	Unsigned8	0
	Block_Object	Unsigned8	0x03, transducer block
	Parent_Class	Unsigned8	244, manufacture specific
	Class	Unsigned8	250, not used
	Dev_Rev	Unsigned16	1
	Dev_Rev_Comp	Unsigned16	1
	DD_Revision	Unsigned16	0
	Profile	OctetString(2)	MSB: 0x40 -> Number of the PROFIBUS PA profiles within PI Profile Class 64 LSB: 0x02 -> Class B
	Profile_Revision	Unsigned16	0x302: PA Profile Revision 3.02
	Execution_Time	Unsigned8	0
16	Number_of_Parameters	Unsigned16	52, number of parameters
	Address_of_View_1	Unsigned16	0x05F8, View_1 has an index 248
	Number_of_Views	Unsigned8	1, one View_1
	17	ST_REV	Unsigned16
18	TAG_DESC	OctetString(32)	
19	STRATEGY	Unsigned16	
20	ALERT_KEY	Unsigned8	
21	TARGET_MODE	Unsigned8	Target mode
22	MODE_BLK	Record	

	Actual_mode	Unsigned8	Actual mode
	Permitted_mode	Unsigned8	Permitted mode
	Normal_mode	Unsigned8	Normal mode
23	ALARM_SUM	Record	
	Current	OctetString(2)	Current alarm
	Unacknowledged	OctetString(2)	Unacknowledged alarm
	Unreported	OctetString(2)	Unreported alarm
	Disabled	OctetString(2)	Disabled alarm
24	PRIMARY_VALUE	Record	Primary value and status (Pressure)
	Value	Float	Primary value
	Status	Unsigned8	Primary status
25	PV_UNIT	Unsigned16	Primary value unit (Pressure engineering units)
26	SECONDARY_VALUE	Record	Secondary value and status (Process Temperature)
	Value	Float	Secondary value
	Status	Unsigned8	Secondary status
27	SV_UNIT	Unsigned16	Secondary value unit (Temperature units)
28	TERTIARY_VALUE	Record	Tertiary value and status (Ambient Temperature)
	Value	Float	Tertiary value
	Status	Unsigned8	Tertiary status
29	TV_UNIT	Unsigned16	Tertiary value unit (Temperature units)
30	QUATERNARY_VALUE	Record	Quaternary value and status (Pressure)
	Value	Float	Quaternary value
	Status	Unsigned8	Quaternary status
31	QV_UNIT	Unsigned16	Quaternary value unit (Pressure engineering units)
32	INTERNAL_MAN_ID	Unsigned16	INTERNAL device manufacture ID
33	INTERNAL_DEV_TYPE	Unsigned16	INTERNAL device type
34	INTERNAL_DEV_ID	Unsigned32	INTERNAL device ID
35	INTERNAL_DEV_REV	Unsigned8	INTERNAL device revision
36	INTERNAL_SW_REV	Unsigned8	INTERNAL device software revision
37	INTERNAL_HW_REV	Unsigned8	INTERNAL device hardware revision
38	INTERNAL_TAG_DESC_DATE	Record	INTERNAL TAG, Descriptor and Date record
	Tag	VisibleString(8)	INTERNAL tag
	Descriptor	VisibleString(16)	INTERNAL descriptor
	Day	Unsigned8	Day
	Month	Unsigned8	Month
	Year	Unsigned8	Year
39	INTERNAL_CMD_MAJOR_REV	Unsigned8	INTERNAL command major revision
40	INTERNAL_MESSAGE	VisibleString(32)	INTERNAL message
41	SIMULATION_VALUE	Record	Simulation value and status
	Value	Float	Simulation value
	Status	Unsigned8	Simulation status
42	COMM_STATE	Unsigned8	INTERNAL communication status
43	PV LRV	Float	Transducer Lower Range Value (Zero)
44	PV URV	Float	Transducer Upper Range Value (Span)
45	PV DAMPING VALUE	Float	PV damping value in seconds
46	RESERVED	Float	
47	RESERVED	Float	
48	RESERVED	Float	
49	RESERVED	Float	
50	RESERVED	Float	
51	RESERVED	Float	
52	RESERVED	Float	
53	PV MOUNT CORRECTION	Unsigned16	(0: reset, 1: correct mounting effect with measured pressure)

54	DEVICE SETTINGS	Unsigned16	Bitmapped structure Bit 0 = Reverse Output Bit 1 = Secondary display reading Bit 2-3 = Backlight Bit 4-6 = Language Bit 7-10 = Primary display reading Bit 11-15 = Reserved
55	RESERVED	Unsigned16	
56	RESERVED	Unsigned16	
57	RESERVED	Unsigned16	
58	RESERVED	Unsigned16	
59	RESERVED	Unsigned16	
60	RESERVED	Unsigned16	
61	RESERVED	Unsigned32	
62	RESERVED	Unsigned32	
63	RESERVED	Unsigned32	
64	RESERVED	Unsigned32	
65	RESERVED	Unsigned32	
66	RESERVED	OctetString(32)	
67	RESERVED	OctetString(32)	

**Analog Input Block Parameters (Slot 1 - 4)**

In the table below the Analog Input Block parameters.

Index	Name	Type	Description
16	BLOCK_OBJECT	Record	Block object
	Reserved	Unsigned8	0
	Block_Object	Unsigned8	0x02, function block
	Parent_Class	Unsigned8	0x01, input
	Class	Unsigned8	0x01, analog input
	Dev_Rev	Unsigned16	1
	Dev_Rev_Comp	Unsigned16	1
	DD_Revision	Unsigned16	0
	Profile	OctetString(2)	MSB: 0x40 -> Number of the PROFIBUS PA profiles within PI Profile Class 64 LSB: 0x02 -> Class B
	Profile_Revision	Unsigned16	0x302: PA Profile Revision 3.02
	Execution_Time	Unsigned8	0
	Number of Parameters	Unsigned16	45, number of parameters
Address_of_View_1	Unsigned16	(0x01F8, 0x02F8, 0x03F8, 0x04F8 for different AI blocks) View_1 has an index 248	
Number_of_Views	Unsigned8	1, only one View_1 in Device	
17	ST_REV	Unsigned16	ST_REV shall be incremented at least by one if at least one static parameter in the corresponding block has been modified
18	TAG_DESC	OctetString(32)	
19	STRATEGY	Unsigned16	
20	ALERT_KEY	Unsigned8	
21	TARGET_MODE	Unsigned8	Target mode
22	MODE_BLK	Record	
	Actual_mode	Unsigned8	Actual mode
	Permitted_mode	Unsigned8	Permitted mode
	Normal_mode	Unsigned8	Normal mode
23	ALARM_SUM	Record	
	Current	OctetString(2)	Current alarm
	Unacknowledged	OctetString(2)	Unacknowledged alarm
	Unreported	OctetString(2)	Unreported alarm
	Disabled	OctetString(2)	Disabled alarm

24	BATCH	Record	Batch structure
	Batch_ID	Unsigned32	Identifies a certain batch to allow assignment of equipment-related information (e.g. faults, alarms ...) to the batch
	Rup	Unsigned16	No. of Recipe Unit Procedure or of Unit
	Operation	Unsigned16	No. of Recipe Operation
	Phase	Unsigned16	No. of Recipe Phase
25	NULL_PARAM	--	
26	OUT	Record	Output of the AI block
	Value	Float	Output value
	Status	Unsigned8	Output status
27	PV_SCALE	Array	Conversion of the Process Variable into percent using the high and low scale values
	PV_SCALE.EU_at_100%	Float	Element 0 of the array: value at EU of 100%
	PV_SCALE.EU_at_0%	Float	Element 1 of the array: value at EU of 0%
28	OUT_SCALE	Record	Scale of the Process Variable
	EU_at_100%	Float	
	EU_at_0%	Float	
	Units_Index	Unsigned16	
	Decimal_Point	Unsigned8	
29	LIN_TYPE	Unsigned8	Type of linearization
30	CHANNEL	Unsigned16	Reference to the active Transducer Block which provides the measurement value to the Function Block
31	NULL_PARAM	--	
32	PV_FTIME	Float	Filter time of the Process Variable
33	FSAFE_TYPE	Unsigned8	Defines the reaction of the device, if a fault is detected
34	FSAFE_VALUE	Float	Default value for the OUT parameter, if a sensor or sensor electronic fault is detected. The unit of this parameter is the same like the OUT one
35	ALARM_HYS	Float	Hysteresis
36	NULL_PARAM	--	
37	HI_HI_LIM	Float	Value for upper limit of alarms
38	NULL_PARAM	--	
39	HI_LIM	Float	Value for upper limit of warnings
40	NULL_PARAM	--	
41	LO_LIM	Float	Value for lower limit of warnings
42	NULL_PARAM	--	
43	LO_LO_LIM	Float	Value for lower limit of alarms
44	NULL_PARAM	--	
45	NULL_PARAM	--	
46	HI_HI_ALM	Record	
	Unacknowledged	Unsigned8	State of the upper limit of alarms.
	Alarm_State	Unsigned8	
	Time_Stamp	TimeValue	
	Subcode	Unsigned16	
	Value	Float	
47	HI_ALM	Record	State of the upper limit of warnings
	Unacknowledged	Unsigned8	
	Alarm_State	Unsigned8	
	Time_Stamp	TimeValue	
	Subcode	Unsigned16	
48	LO_ALM	Record	State of the lower limit of warnings
	Unacknowledged	Unsigned8	
	Alarm_State	Unsigned8	
	Time_Stamp	TimeValue	

	Subcode	Unsigned16	
	Value	Float	
49	LO_LO_ALM	Record	State of the lower limit of alarms
	Unacknowledged	Unsigned8	
	Alarm_State	Unsigned8	
	Time_Stamp	TimeValue	
	Subcode	Unsigned16	
	Value	Float	
50	SIMULATE	Record	For commissioning and test purposes the input value from the Transducer Block into the Analog Input Function Block AI-FB can be modified. That means that the Transducer and AI-FB will be disconnected
	Simulate_Status	Unsigned8	
	Simulate_Value	Float	
	Simulate_Enable	Unsigned8	
51	OUT_UNIT_TEXT	OctetString(16)	

## 7.2 IDENT NUMBER

Profibus devices have a unique ID number. An ID allows device identification connected to the bus. The Ident Number of the DP-4000 is: 0FAB (hex). The Ident Number is also stored in the GSD File.

## 7.3 GSD FILES

GSD (General Station Description) Files are needed to configure a profibus network. GSD files containing general information and device-specific capabilities about the transmitter. The PLC or a configuration tool reads the device identification, adjustable parameters, data type and the limiting values of the transmitter from this GSD file. The GSD file is usable for all Profibus master that are compatible to the standard and configured for the floating point standard **IEEE754**.

The GSD files are available at: [www.klay.nl](http://www.klay.nl) under section downloads.



## 7.4 ENGINEERING UNITS

The following engineering units are supported by the Series 4000 Profibus PA.

Index	Unit	Description
1132	MPa	megapascal
1133	kPa	kilopascal
1137	bar	bar
1138	mbar	millibar
1140	atm	atmosphere
1145	kgf/cm <sup>2</sup>	kilogram-force per square centimeter
1147	inH <sub>2</sub> O (4°C)	inch of water at 4 °C
1150	mmH <sub>2</sub> O (4°C)	millimeter of water at 4 °C
1158	mmHg (0°C)	millimeter of mercury
1001	° C	Celsius
1002	° F	Fahrenheit

Additional units can be configured in the Analog Input Block. This is explained step by step by an example:

- The Span is set to 1.000 bar in program point P102. (0 till 1.000 bar)
- In the Analog Input Block index value 27 is automatically filled with calibrated span of 1.000 bar.
- In the Analog Input Block index value 28 must be filled in for scaling from bar to torr:
- **OUT\_SCALE** = 750.06375541921 (1 bar = 750.06375541921 torr)
- **EU\_at\_100%** = 750.06375541921 and **EU\_at\_0%** = 0
- **Units\_Index** = 1139 (Corresponding Engineering unit for torr)
- **Decimal\_Point** = 2
- The converted output is available on index value 26 (OUT) in the Analog Input Block.



When the Engineering Unit is changed on the transmitter with Programming point P104 or P109, the conversion in the Analog Input Block will be invalid and must re-calculated and configured as described above. The same applies when the SPAN is changed.

Configuring the transmitter local and remote simultaneously will cause transmission errors and must be prevented.

## 7.5 PROFIBUS ADDRESS

The DP-4000-PROFIBUS PA is standard configured at address **126** (Unconfigured Device). This address is used for configuration and commissioning purpose only. The address can be changed with Program point P113 or a Profibus Master device (Only Class 2).

## 7.2 ROTATABLE DISPLAY

The display from the DP-4000 is fully rotatable. To rotate the display, place a small screw driver into the recess on top of the display. Turn it by hand by moving the screw driver into the desired direction, use the other hand to guide this movement to avoid any damages. The display can be turned both left and right.



## 8. SPECIFICATIONS

<b>Manufacturer</b>		Klay Instruments B.V.		
<b>Instrument</b>		Series DP-4000		
<b>Output</b>		Profibus PA - Slave Profile V3.02 Floating point IEEE754		
<b>Power Supply</b>		12 - 30 Vdc		
<b>Transmission speed</b>		31.25 kb/sec		
<b>Current consumption</b>		13 mA ± 1 mA		
<b>Fault current</b>		13 mA ± 1 mA		
<b>Accuracy<sup>1</sup></b>		TD 10:1 - 0.075 % TD 20:1 - 0.1 % TD 40:1 - 0.15 % TD > 40:1 – 0.005 % x TD		
<b>Ranges</b>	Code	Adjustable span ranges		Max. overpressure
		Min. Span	Max. Span	
<b>Series DP-4000</b>	A	0 - 10 mbar	0 - 60 mbar	160 bar
	B	0 - 10 mbar	0 - 400 mbar	
	C	0 - 20 mbar	0 - 2000 mbar	
	D	0 – 0,2 bar	0 – 20 bar	
<b>Process Temperature<sup>2</sup></b>		-20°C to +80°C (-4°F to 176°F) (Optional 100°C)		
<b>Ambient Temperature</b>		-20°C to +70°C (-4°F to 158°F)		
<b>Damping</b>		0,00 seconds to 25,00 seconds Standard: 0,00 seconds.		
<b>Protection Grade</b>		IP66		
<b>Material</b>	Housing “Wetted” parts	AISI 304 (Optional AISI 316) AISI 316 L and Viton O-Ring (Other materials on request)		

1: To achieve the highest accuracy, always choose the instrument range closest to the required Calibrated span .  
Example: Required Calibrated range 0 – 300 mbar, choose range B

2: For higher temperatures use other kind of pressure transmitters, or contact Klay Instruments for information.

## 9. PRECAUTIONS AND WARNINGS

- Check if the specifications of the transmitter meet the needs of the process conditions
- When the Series DP-4000 is used as a level transmitter, be aware of the place where the transmitter is mounted. Here are some suggestions:
  1. DO NOT mount a level transmitter in- or near filling or discharging pipes.
  2. In case of automatic cleaning systems or hand cleaning: never point the water jets on the diaphragm, take necessary steps to avoid this. Guarantee will not be granted.
- When the Series DP-4000 is used as a pressure transmitter, be aware of the following points:
  1. Rapid closing valves in combination with high flow velocity will cause water hammer(spikes) and can destroy the transmitter. DO NOT mount a transmitter near such valves, always a few pipe bends away up or down stream (avoid suction).
  2. Install a pressure transmitter a few pipe bends away from pumps, as well on the suction or pressure side of the pump
- The diaphragm of the transmitter or remote seals are protected with a special protection cap. Protect the diaphragm until installation takes place, to prevent damaging of the diaphragm.
- As soon as the wiring is brought inside through the cable gland and connected to the terminal board, make sure the cable gland is tightly fixed, so that moisture cannot enter into the electronic housing.
- The covers ① and ③ must be fully engaged, so that moisture cannot ingress into the electronic housing.
- WARRANTY: The warranty is 1 year from delivery date.  
Klay Instruments B.V. does not accept liability for consequential damage of any kind due to use or misuse of the Series DP-4000. Warranty will be given, to be decided by the manufacturer. Transmitter must be shipped prepaid to the factory on manufacturers authorization.
- NOTE: Klay Instruments B.V. reserves the right to change its specifications at any time, without notice. Klay Instruments B.V. is not an expert in the customers process (technical field) and therefore does not warrant the suitability of its product for the application selected by the customer.

**Manufactured by:** **KLAY-INSTRUMENTS B.V.**[www.klay.nl](http://www.klay.nl)

Nijverheidsweg 5

P.O. Box 13

Tel: +31-521-591550

Fax: +31 -521-592046

7991 CZ DWINGELOO

7990 AA DWINGELOO

The Netherlands

E-Mail: [info@klay.nl](mailto:info@klay.nl)

Value	Symbol	Description	Value	Symbol	Description
1000	K	kelvin	1069	in/min	inch per minute
1001	°C	degree Celsius	1070	ft/min	foot per minute
1002	°F	degree Fahrenheit	1071	yd/min	yard per minute
1003	°R	degree Rankine	1072	in/h	inch per hour
1004	rad	radian	1073	ft/h	foot per hour
1005	°	degree	1074	yd/h	yard per hour
1006	'	minute	1075	mi/h	mile per hour
1007	"	second	1076	m/s <sup>2</sup>	meter per second squared
1008	gon	gon (or grade)	1077	Hz	hertz
1009	r	revolution	1078	THz	terahertz
1010	m	meter	1079	GHz	gigahertz
1011	km	kilometer	1080	MHz	megahertz
1012	cm	centimeter	1081	kHz	kilohertz
1013	mm	millimeter	1082	1/s	per second
1014	µm	micrometer	1083	1/min	per minute
1015	nm	nanometer	1084	r/s	revolution per second
1016	pm	picometer	1085	rpm r/min	revolution per minute
1017	Å	angstrom	1086	rad/s	radian per second
1018	ft	foot	1087	1/s <sup>2</sup>	per second squared
1019	in	inch (international)	1088	kg	kilogram
1020	yd	yard	1089	g	gram
1021	mile	mile	1090	mg	milligram
1022	nautical mile	nautical mile	1091	Mg	mega gram
1023	m <sup>2</sup>	square meter	1092	t	metric ton
1024	km <sup>2</sup>	square kilometer	1093	oz	ounce (Avoirdupois)
1025	cm <sup>2</sup>	square centimeter	1094	lb	pound (Avoirdupois)
1026	dm <sup>2</sup>	square decimeter	1095	STon	short ton
1027	mm <sup>2</sup>	square millimeter	1096	LTon	long ton
1028	a	are	1097	kg/m <sup>3</sup>	kilogram per cubic meter
1029	ha	hectare	1098	Mg/m <sup>3</sup>	mega gram per cubic meter
1030	in <sup>2</sup>	square inch	1099	kg/dm <sup>3</sup>	kilogram per cubic decimeter
1031	ft <sup>2</sup>	square feet	1100	g/cm <sup>3</sup>	gram per cubic centimeter
1032	yd <sup>2</sup>	square yard	1101	g/m <sup>3</sup>	gram per cubic meter
1033	mile <sup>2</sup>	square mile	1102	t/m <sup>3</sup>	metric ton per cubic meter
1034	m <sup>3</sup>	cubic meter	1103	kg/L	kilogram per liter
1035	dm <sup>3</sup>	cubic decimeter	1104	g/ml	gram per milliliter
1036	cm <sup>3</sup>	cubic centimeter	1105	g/L	gram per liter
1037	mm <sup>3</sup>	cubic millimeter	1106	lb/in <sup>3</sup>	pound per cubic inch
1038	L	liter	1107	lb/ft <sup>3</sup>	pound per cubic foot
1039	cl	centiliter	1108	lb/gal	pound per gallon (U.S.)
1040	ml	milliliter	1109	STon/yd <sup>3</sup>	short ton per cubic yard
1041	hl <sup>3</sup>	hectoliter	1110	°Twad	degree Twaddell
1042	in <sup>3</sup>	cubic inch	1111	°Baum (hv)	degree Baume heavy
1043	ft <sup>3</sup>	cubic foot	1112	°Baum (lt)	degree Baume light
1044	yd <sup>3</sup>	cubic yard	1113	°API	degree API
1045	mile <sup>3</sup>	cubic mile	1114	SGU	specific gravity units
1046	pint (U.S. liquid)	pint (U.S. liquid)	1115	kg/m	kilogram per meter
1047	quart (U.S. liquid)	quart (U.S. liquid)	1116	mg/m	milligram per meter
1048	gal	gallon (U.S.)	1117	tex	tex
1049	ImpGal	gallon (Imperial)	1118	kg-m <sup>2</sup>	kilogram square meter
1050	bushel	bushel (U.S. dry)	1119	kg-m/s	kilogram meter per second
1051	bbl	barrel (U.S. petroleum)	1120	N	newton
1052	bbl (liq)	barrel (U.S. liquid)	1121	MN	mega newton
1053	ft <sup>3</sup> std.	standard cubic foot	1122	kN	kilo newton
1054	s	second	1123	mN	milli newton
1055	ks	kilo second	1124	µN	micro newton
1056	ms	milli second	1125	kg-m <sup>2</sup> /s	kilogram square meter per second
1057	µs	micro second	1126	N·m	newton meter
1058	min	minute	1127	MN·m	mega newton meter
1059	h	hour	1128	kN·m	kilo newton meter
1060	d	day	1129	mN·m	milli newton meter
1061	m/s	meter per second	1130	Pa	pascal
1062	mm/s	millimeter per second	1131	GPa	giga pascal
1063	m/h	meter per hour	1132	MPa	mega pascal
1064	km/h	kilometer per hour	1133	kPa	kilo pascal
1065	knot	nautical mile per hour	1134	mPa	milli pascal
1066	in/s	inch per second	1135	µPa	micro pascal
1067	ft/s	foot per second	1136	hPa	hector pascal
1068	yd/s	yard per second	1137	bar	bar

Value	Symbol	Description	Value	Symbol	Description
1138	mbar	millibar	1207	MJ/kg	megajoule per kilogram
1139	torr	torr	1208	kJ/kg	kilojoule per kilogram
1140	atm	atmosphere	1209	A	ampere
1141	lbf/in <sup>2</sup> psi	pound-force per square inch	1210	kA	kilo ampere
1142	lbf/in <sup>2</sup> a psia	pound-force per square inch absolute	1211	mA	milli ampere
1143	lbf/in <sup>2</sup> g psig	pound-force per square inch gauge	1212	µA	micro ampere
1144	gf/cm <sup>2</sup>	gram-force per square centimeter	1213	nA	nano ampere
1145	kgf/cm <sup>2</sup>	kilogram-force cm <sup>2</sup>	1214	pA	pico ampere
1146	inH2O	inch of water	1215	C	coulomb
1147	inH2O (4°C)	inch of water at 4°C	1216	MC	mega coulomb
1148	inH2O (68°F)	inch of water at 68°F	1217	kC	kilo coulomb
1149	mmH2O	millimeter of water	1218	µC	micro coulomb
1150	mmH2O (4°C)	millimeter of water at 4°C	1219	nC	nano coulomb
1151	mmH2O (68°F)	millimeter of water at 68°F	1220	pC	pico coulomb
1152	ftH2O	foot of water	1221	A·h	ampere hour
1153	ftH2O (4°C)	foot of water at 4°C	1222	C/m <sup>3</sup>	coulomb per cubic meter
1154	ftH2O (68°F)	foot of water at 68°F	1223	C/mm <sup>3</sup>	coulomb per cubic millimeter
1155	inHg	inch of mercury	1224	C/cm <sup>3</sup>	coulomb per cubic centimeter
1156	inHg (0°C)	inch of mercury at 0°C	1225	kC/m <sup>3</sup>	kilo coulomb per cubic meter
1157	mmHg	millimeter of mercury	1226	mC/m <sup>3</sup>	milli coulomb per cubic meter
1158	mmHg (0°C)	millimeter of mercury at 0°C	1227	µC/m <sup>3</sup>	micro coulomb per cubic meter
1159	Pa·s	pascal second	1228	C/m <sup>2</sup>	coulomb per square meter
1160	m <sup>2</sup> /s	square meter per second	1229	C/mm <sup>2</sup>	coulomb per square millimeter
1161	P	poise	1230	C/cm <sup>2</sup>	coulomb per square centimeter
1162	cP	centipoise	1231	kC/m <sup>2</sup>	kilo coulomb per square meter
1163	St	stokes	1232	mC/m <sup>2</sup>	milli coulomb per square meter
1164	cSt	centistokes	1233	µC/m <sup>2</sup>	micro coulomb per square meter
1165	N/m	Newton per meter	1234	V/m	volt per meter
1166	mN/m	milli newton per meter	1235	MV/m	megavolt per meter
1167	J	joule	1236	kV/m	kilovolt per meter
1168	EJ	exa joules	1237	V/cm	volt per centimeter
1169	PJ	peta joules	1238	mV/m	millivolt per meter
1170	TJ	tera joules	1239	µV/m	microvolt per meter
1171	GJ	giga joules	1240	V	volt
1172	MJ	mega joules	1241	MV	megavolt
1173	kJ	kilojoules	1242	kV	kilovolt
1174	mJ	milli joules	1243	mV	millivolt
1175	W·h	watt hour	1244	µV	microvolt
1176	TW·h	terawatt hour	1245	F	farad
1177	GW·h	gigawatt hour	1246	mF	milli farad
1178	MW·h	megawatt hour	1247	µF	micro farad
1179	kW·h	kilowatt hour	1248	nF	nano farad
1180	calth	calorie (thermochemical)	1249	pF	pico farad
1181	kcalth	kilocalorie (thermochemical)	1250	F/m	farad per meter
1182	Mcalth	mega calorie (thermochemical)	1251	µF/m	micro farad per meter
1183	Btuth	British thermal unit	1252	nF/m	nano farad per meter
1184	datherm	dekatherm	1253	pF/m	pico farad per meter
1185	ft·lbf	foot pound-force	1254	C·m	coulomb meter
1186	W	watt	1255	A/m <sup>2</sup>	ampere per square meter
1187	TW	tera watt	1256	MA/m <sup>2</sup>	mega ampere per square meter
1188	GW	giga watt	1257	A/cm <sup>2</sup>	ampere per square centimeter
1189	MW	mega watt	1258	kA/m <sup>2</sup>	kilo ampere per square meter
1190	kW	kilo watt	1259	A/m	ampere per meter
1191	mW	milli watt	1260	kA/m	kilo ampere per meter
1192	µW	micro watt	1261	A/cm	ampere per centimeter
1193	nW	nano watt	1262	T	tesla
1194	pW	pico watt	1263	mT	milli tesla
1195	Mcalth/h	mega calorie per hour	1264	µT	micro tesla
1196	MJ/h	mega joule per hour	1265	nT	nano tesla
1197	Btuth/h	British thermal unit per hour	1266	Wb	weber
1198	hp	horsepower (electric)	1267	mWb	milli weber
1199	W/(m·K)	watt per meter kelvin	1268	Wb/m	weber per meter
1200	W/(m <sup>2</sup> ·K)	watt per square meter kelvin	1269	kWb/m	kilo weber per meter
1201	m <sup>2</sup> ·K/W	square meter kelvin per watt	1270	H	henry
1202	J/K	joule per kelvin	1271	mH	milli henry
1203	kJ/K	kilo joule per kelvin	1272	µH	micro henry
1204	J/(kg·K)	joule per kilogram kelvin	1273	nH	nano henry
1205	kJ/(kg·K)	kilo joule per kilogram kelvin	1274	pH	pico henry
1206	J/kg	joule per kilogram	1275	H/m	henry per meter

Value	Symbol	Description	Value	Symbol	Description
1276	μH/m	micro henry per meter	1345	% stm qual	percent steam quality
1277	nH/m	nano henry per meter	1346	°Plato	degree Plato
1278	A·m <sup>2</sup>	ampere square meter	1347	m <sup>3</sup> /s	cubic meter per second
1279	N·m <sup>2</sup> /A	newton square meter per ampere	1348	m <sup>3</sup> /min	cubic meter per minute
1280	Wb·m	weber meter	1349	m <sup>3</sup> /h	cubic meter per hour
1281	Ω	ohm	1350	m <sup>3</sup> /d	cubic meter per day
1282	GΩ	giga ohm	1351	L/s	liter per second
1283	MΩ	mega ohm	1352	L/min	liter per minute
1284	kΩ	kilo ohm	1353	L/h	liter per hour
1285	mΩ	milli ohm	1354	L/d	liter per day
1286	μΩ	micro ohm	1355	ML/d	mega liter per day
1287	S	siemens	1356	ft <sup>3</sup> /s	cubic foot per second
1288	kS	kilo siemens	1357	ft <sup>3</sup> /min	cubic foot per minute
1289	mS	milli siemens	1358	ft <sup>3</sup> /h	cubic foot per hour
1290	μS	micro siemens	1359	ft <sup>3</sup> /d	cubic foot per day
1291	Ω·m	ohm meter	1360	ft <sup>3</sup> /min std.	standard cubic foot per minute
1292	GΩ·m	giga ohm meter	1361	ft <sup>3</sup> /h std.	standard cubic foot per hour
1293	MΩ·m	meg ohm meter	1362	gal/s	gallon (U.S.) per second
1294	kΩ·m	kilo ohm meter	1363	gal/min	gallon (U.S.) per minute
1295	Ω·cm	ohm centimeter	1364	gal/h	gallon (U.S.) per hour
1296	mΩ·m	milli ohm meter	1365	gal/d	gallon (U.S.) per day
1297	μΩ·m	micro ohm meter	1366	Mgal/d	mega gallon (U.S.) per day
1298	nΩ·m	nano ohm meter	1367	ImpGal/s	gallon (Imperial) per second
1299	S/m	siemens per meter	1368	ImpGal/min	gallon (Imperial) per minute
1300	MS/m	mega siemens per meter	1369	ImpGal/h	gallon (Imperial) per hour
1301	kS/m	kilo siemens per meter	1370	ImpGal/d	gallon (Imperial) per day
1302	mS/cm	milli siemens per centimeter	1371	bbl/s	barrel per second
1303	μS/mm	micro siemens per millimeter	1372	bbl/min	barrel per minute
1304	1/H	per henry	1373	bbl/h	barrel per hour
1305	sr	steradian	1374	bbl/d	barrel per day
1306	W/sr	watt per steradian	1375	W/m <sup>2</sup>	watt per square meter
1307	W/(sr·m <sup>2</sup> )	watt per steradian square meter	1376	mW/m <sup>2</sup>	milli watt per square meter
1308	W/m <sup>2</sup>	watt per square meter	1377	μW/m <sup>2</sup>	micro watt per square meter
1309	lm	lumen	1378	pW/m <sup>2</sup>	pico watt per square meter
1310	lm·s	lumen second	1379	Pa·s/m <sup>3</sup>	pascal second per cubic meter
1311	lm·h	lumen hour	1380	N·s/m	newton second per meter
1312	lm/m <sup>2</sup>	lumen per square meter	1381	Pa·s/m	pascal second per meter
1313	lm/W	lumen per watt	1382	B	bel
1314	lx	lux	1383	dB	decibel
1315	lx·s	lux second	1384	mol	mole
1316	cd	candela	1385	kmol	kilo mole
1317	cd/m <sup>2</sup>	candela per square meter	1386	mmol	milli mole
1318	g/s	gram per second	1387	μmol	micromole
1319	g/min	gram per minute	1388	kg/mol	kilogram per mole
1320	g/h	gram per hour	1389	g/mol	gram per mole
1321	g/d	gram per day	1390	m <sup>3</sup> /mol	cubic meter per mole
1322	kg/s	kilogram per second	1391	dm <sup>3</sup> /mol	cubic decimeter per mole
1323	kg/min	kilogram per minute	1392	cm <sup>3</sup> /mol	cubic centimeter per mole
1324	kg/h	kilogram per hour	1393	L/mol	liter per mole
1325	kg/d	kilogram per day	1394	J/mol	joule per mole
1326	t/s	metric ton per second	1395	kJ/mol	kilojoule per mole
1327	t/min	metric ton per minute	1396	J/(mol·K)	joule per mole kelvin
1328	t/h	metric ton per hour	1397	mol/m <sup>3</sup>	mole per cubic meter
1329	t/d	metric ton per day	1398	mol/dm <sup>3</sup>	mole per cubic decimeter
1330	lb/s	pound per second	1399	mol/L	mole per liter
1331	lb/min	pound per minute	1400	mol/kg	mole per kilogram
1332	lb/h	pound per hour	1401	mmol/kg	milli mole per kilogram
1333	lb/d	pound per day	1402	Bq	becquerel
1334	STon/s	short ton per second	1403	MBq	mega becquerel
1335	STon/min	short ton per minute	1404	kBq	kilo becquerel
1336	STon/h	short ton per hour	1405	Bq/kg	becquerel per kilogram
1337	STon/d	short ton per day	1406	kBq/kg	kilo becquerel per kilogram
1338	LTon/s	long ton per second	1407	MBq/kg	mega becquerel per kilogram
1339	LTon/min	long ton per minute	1408	Gy	gray
1340	LTon/h	long ton per hour	1409	mGy	milli gray
1341	LTon/d	long ton per day	1410	rd	rad
1342	%	percent	1411	Sv	sievert
1343	% sol/wt	percent solid per weight	1412	mSv	milli sievert
1344	% sol/vol	percent solid per volume	1413	rem	rem

Value	Symbol	Description	Value	Symbol	Description
1414	C/kg	coulomb per kilogram	1483	μbbl/min	micro barrel per minute
1415	mC/kg	milli coulomb per kilogram	1484	mbbl/min	milli barrel per minute
1416	R	roentgen	1485	kbbl/min	kilo barrel per minute
1417	1/J·m		1486	Mbbl/min	mega barrel per minute
1418	e/V·m		1487	μbbl/h	micro barrel per hour
1419	m <sup>3</sup> /C	cubic meter per coulomb	1488	mbbl/h	milli barrel per hour
1420	V/K	volt per kelvin	1489	kbbl/h	kilo barrel per hour
1421	mV/K	millivolt per kelvin	1490	Mbbl/h	mega barrel per hour
1422	pH	pH	1491	μbbl/d	micro barrel per day
1423	ppm	parts per million	1492	mbbl/d	milli barrel per day
1424	ppb	parts per billion	1493	kbbl/d	kilo barrel per day
1425	ppth	parts per thousand	1494	Mbbl/d	mega barrel per day
1426	°Brix	degree Brix	1495	μm <sup>3</sup> /s	cubic micrometer per second
1427	°Ball	degree Balling	1496	mm <sup>3</sup> /s	cubic millimeter per second
1428	proof/vol	proof per volume	1497	km <sup>3</sup> /s	cubic kilo meter per second
1429	proof/mass	proof per mass	1498	Mm <sup>3</sup> /s	cubic mega meter per second
1430	lb/ImpGal	pound per gallon (Imperial)	1499	μm <sup>3</sup> /min	cubic micrometer per minute
1431	kcalth/s	kilocalorie per second	1500	mm <sup>3</sup> /min	cubic millimeter per minute
1432	kcalth/min	kilocalorie per minute	1501	km <sup>3</sup> /min	cubic kilometer per minute
1433	kcalth/h	kilocalorie per hour	1502	Mm <sup>3</sup> /min	cubic mega meter per minute
1434	kcalth/d	kilocalorie per day	1503	μm <sup>3</sup> /h	cubic micrometer per hour
1435	Mcalth/s	mega calorie per second	1504	mm <sup>3</sup> /h	cubic millimeter per hour
1436	Mcalth/min	mega calorie per minute	1505	km <sup>3</sup> /h	cubic kilometer per hour
1437	Mcalth/d	mega calorie per day	1506	Mm <sup>3</sup> /h	cubic mega meter per hour
1438	kJ/s	kilojoule per second	1507	μm <sup>3</sup> /d	cubic micrometer per day
1439	kJ/min	kilojoule per minute	1508	mm <sup>3</sup> /d	cubic millimeter per day
1440	kJ/h	kilojoule per hour	1509	km <sup>3</sup> /d	cubic kilometer per day
1441	kJ/d	kilojoule per day	1510	Mm <sup>3</sup> /d	cubic mega meter per day
1442	MJ/s	mega joule per second	1511	cm <sup>3</sup> /s	cubic centimeter per second
1443	MJ/min	mega joule per minute	1512	cm <sup>3</sup> /min	cubic centimeter per minute
1444	MJ/d	mega joule per day	1513	cm <sup>3</sup> /h	cubic centimeter per hour
1445	Btuth/s	British thermal unit per second	1514	cm <sup>3</sup> /d	cubic centimeter per day
1446	Btuth/min	British thermal unit per minute	1515	kcalth/kg	kilocalorie per kilogram
1447	Btuth/day	British thermal unit per day	1516	Btuth/lb	British thermal unit per pound
1448	μgal/s	micro gallon (U.S.) per second	1517	kL	kiloliter
1449	mgal/s	milli gallon (U.S.) per second	1518	kL/min	kiloliter per minute
1450	kgal/s	kilo gallon (U.S.) per second	1519	kL/h	kiloliter per hour
1451	Mgal/s	mega gallon (U.S.) per second	1520	kL/d	kiloliter per day
1452	μgal/min	micro gallon (U.S.) per minute	1521	vendor-specific 1521	
1453	mgal/min	milli gallon (U.S.) per second	1522	vendor-specific 1522	
1454	kgal/min	kilo gallon (U.S.) per minute	1523	vendor-specific 1523	
1455	Mgal/min	mega gallon (U.S.) per minute	1524	vendor-specific 1524	
1456	μgal/h	micro gallon (U.S.) per hour	1525	vendor-specific 1525	
1457	mgal/h	milli gallon (U.S.) per hour	1526	vendor-specific 1526	
1458	kgal/h	kilo gallon (U.S.) per hour	1527	vendor-specific 1527	
1459	Mgal/h	mega gallon (U.S.) per hour	1528	vendor-specific 1528	
1460	μgal/d	micro gallon (U.S.) per day	1529	vendor-specific 1529	
1461	mgal/d	milli gallon (U.S.) per day	1530	vendor-specific 1530	
1462	kgal/d	kilo gallon (U.S.) per day	1531	vendor-specific 1531	
1463	μImpGal/s	micro gallon (Imperial) per second	1532	vendor-specific 1532	
1464	mImpGal/s	milli gallon (Imperial) per second	1533	vendor-specific 1533	
1465	kImpGal/s	kilo gallon (Imperial) per second	1534	vendor-specific 1534	
1466	MImpGal/s	mega gallon (Imperial) per second	1535	vendor-specific 1535	
1467	μImpGal/min	micro gallon (Imperial) per minute	1536	vendor-specific 1536	
1468	mImpGal/min	milli gallon (Imperial) per minute	1537	vendor-specific 1537	
1469	kImpGal/min	kilo gallon (Imperial) per minute	1538	vendor-specific 1538	
1470	MImpGal/min	mega gallon (Imperial) per minute	1539	vendor-specific 1539	
1471	μImpGal/h	micro gallon (Imperial) per hour	1540	vendor-specific 1540	
1472	mImpGal/h	milli gallon (Imperial) per hour	1541	vendor-specific 1541	
1473	kImpGal/h	kilo gallon (Imperial) per hour	1542	vendor-specific 1542	
1474	MImpGal/h	mega gallon (Imperial) per hour	1543	vendor-specific 1543	
1475	μImpGal/d	micro gallon (Imperial) per day	1544	vendor-specific 1544	
1476	mImpGal/d	milli gallon (Imperial) per day	1545	vendor-specific 1545	
1477	kImpGal/d	kilo gallon (Imperial) per day	1546	vendor-specific 1546	
1478	MImpGal/d	mega gallon (Imperial) per day	1547	vendor-specific 1547	
1479	μbbl/s	micro barrel per second	1548	vendor-specific 1548	
1480	mbbl/s	milli barrel per second	1549	vendor-specific 1549	
1481	kbbl/s	kilo barrel per second	1550	vendor-specific 1550	
1482	Mbbl/s	mega barrel per second	1551	S/cm	siemens per centimeter



Value	Symbol	Description
1552	μS/cm	micro siemens per centimeter
1553	mS/m	milli siemens per meter
1554	μS/m	micro siemens per meter
1555	MΩ·cm	Mega ohm centimeter
1556	kΩ·cm	kilo ohm centimeter
1557	Gew%	Gewichts prozent
1558	mg/L	milligram per liter
1559	μg/L	microgram per liter
1560	%Sät	
1561	vpm	
1562	%vol	Volume percent
1563	ml/min	milliliter per minute
1564	mg/dm <sup>3</sup>	milligram per cubic decimeter
1565	mg/L	milligram per liter <small>(do not use in new projects; use 1558)</small>
1566	mg/m <sup>3</sup>	milligram per cubic meter
1567	ct	carat (jewel)
1568	lb (tr)	pound (troy or apothecary)
1569	oz (tr)	ounce (troy or apothecary)
1570	fl oz (U.S.)	ounce (U.S. fluid)
1571	cm	cubic centimeter
1572	af	acre foot
1573	m <sup>3</sup> normal	Normal m <sup>3</sup> (0°C, 1atm = 101325Pa)
1574	L normal	Normal liter (0°C, 1atm = 101325PA)
1575	m <sup>3</sup> std.	Standard m <sup>3</sup> (20°C, 1atm = 101325Pa)
1576	L std.	Standard liter (20°C, 1atm = 101325PA)
1577	ml/s	milliliter per second
1578	ml/h	milliliter per hour
1579	ml/d	milliliter per day
1580	af/s	acre foot per second
1581	af/min	acre foot per minute
1582	af/h	acre foot per hour
1583	af/d	acre foot per day
1584	fl oz (U.S.)/s	ounce (U.S. fluid) per second
1585	fl oz (U.S.)/min	ounce (U.S. fluid) per minute
1586	fl oz (U.S.)/h	ounce (U.S. fluid) per hour
1587	fl oz (U.S.)/d	ounce (U.S. fluid) per day
1588	m <sup>3</sup> /s normal	Normal m <sup>3</sup> per second (0°C, 1atm = 101325Pa)
1589	m <sup>3</sup> /min normal	Normal m <sup>3</sup> per minute (0°C, 1atm = 101325Pa)
1590	m <sup>3</sup> /h normal	Normal m <sup>3</sup> per hour (0°C, 1atm = 101325Pa)
1591	m <sup>3</sup> /d normal	Normal m <sup>3</sup> per day (0°C, 1atm = 101325PA)
1592	L/s normal	Normal liter per second (0°C, 1atm = 101325PA)
1593	L/min normal	Normal liter per minute (0°C, 1atm = 101325PA)
1594	L/h normal	Normal liter per hour (0°C, 1atm = 101325PA)
1595	L/d normal	Normal liter per day (0°C, 1atm = 101325PA)
1596	m <sup>3</sup> /s std.	Standard cubic meter per second (20°C, 1atm = 101325Pa)
1597	m <sup>3</sup> /min std.	Standard cubic meter per minute (20°C, 1atm = 101325Pa)
1598	m <sup>3</sup> /h std.	Standard cubic meter per hour (20°C, 1atm = 101325Pa)
1599	m <sup>3</sup> /d std.	Standard cubic meter per day (20°C, 1atm = 101325Pa)
1600	L/s std.	Standard liter per second (20°C, 1atm = 101325PA)
1601	L/min std.	Standard liter per minute (20°C, 1atm = 101325PA)
1602	L/h std.	Standard liter per hour (20°C, 1atm = 101325PA)
1603	L/d std.	Standard liter per day (20°C, 1atm = 101325PA)
1604	ft <sup>3</sup> /s std.	standard cubic foot per second
1605	ft <sup>3</sup> /d std.	standard cubic foot per day
1606	oz/s	ounce per second

Value	Symbol	Description
1607	oz/min	ounce per minute
1608	oz/h	ounce per hour
1609	oz/d	ounce per day
1610	Paa	pascal absolute
1611	Pag	pascal gauge
1612	GPaa	giga pascal absolute
1613	GPag	giga pascal gauge
1614	MPaa	mega pascal absolute
1615	MPag	mega pascal gauge
1616	kPaa	kilopascal absolute
1617	kPag	kilopascal gauge
1618	mPaa	milli pascal absolute
1619	mPa g	milli pascal gauge
1620	μPaa	micro pascal absolute
1621	μPag	micro pascal gauge
1622	hPaa	hector pascal absolute
1623	hPag	hector pascal gauge
1624	gf/cm <sup>2</sup> a	gram-force per cm <sup>2</sup> absolute
1625	gf/cm <sup>2</sup> g	gram-force per cm <sup>2</sup> gauge
1626	kgf/cm <sup>2</sup> a	kilogram-force per cm <sup>2</sup> absolute
1627	kgf/cm <sup>2</sup> g	kilogram-force per cm <sup>2</sup> gauge
1628	SD4°C	standard density at 4°C
1629	SD15°C	standard density at 15°C
1630	SD20°C	standard density at 20°C
1631	PS	metric horsepower (Pferdestärke)
1632	ppt	parts per trillion
1633	hl/s	hectoliter per second
1634	hl/min	hectoliter per minute
1635	hl/h	hectoliter per hour
1636	hl/d	hectoliter per day
1637	bbl (liq)/s	barrel (U.S. liquid) per second
1638	bbl (liq)/min	barrel (U.S. liquid) per minute
1639	bbl (liq)/h	barrel (U.S. liquid) per hour
1640	bbl (liq)/d	barrel (U.S. liquid) per day
1641	bbl (fed)	barrel (U.S. federal)
1642	bbl (fed)/s	barrel (U.S. federal) per second
1643	bbl (fed)/min	barrel (U.S. federal) per minute
1644	bbl (fed)/h	barrel (U.S. federal) per hour
1645	bbl (fed)/d	barrel (U.S. federal) per day
1646	Reserved	
1994	Reserved	
1995	Textual unit definition	
1996	Not used	
1997	None	
1998	unknown	
1999	special	