

# ATKOMATIC

## ATKOMATIC Solenoid Valves *Index*

Product Line Overview	1	8000 Series	36
How to Order	3	12000 Series	39
Product Matrix	6	13000 Series	41
JJ Series	8	14000 Series	44
HS Series	10	15400 Series	46
15-794 Series	12	15800 Series	49
500 Series	14	16000 Series	51
1000 Series	18	30400 Series	55
2000 Series	21	30800 Series	59
3000 Series	24	35800 Series	62
4000 & 5000 Series	27	40000 Series	65
6000 Series	31	50000 Series	68
7000 Series	34	Options	71



*atkomatic solenoid*

### Circle Seal Controls

2301 Wardlow Circle • P.O. Box 3300 • Corona, CA 92880

Phone (951) 270-6200 Fax (951) 270-6201

[www.circlesealcontrols.com](http://www.circlesealcontrols.com)

# ATKOMATIC

## ATKOMATIC Solenoid Valves

Heavy-duty Process Solenoid Valves for Clean Air, Gases, Liquids, Steam, Corrosive Fluids & Cryogenic Fluids

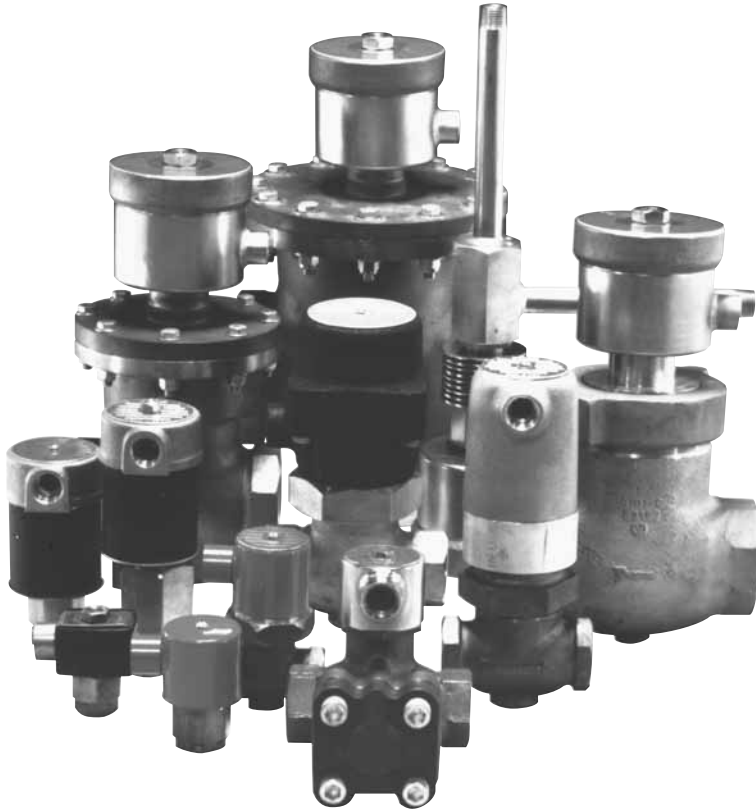

atkomatic solenoid

### Overview of Product Line

#### General

- Solenoid valves to meet a wide variety of industrial applications
- 2 position, 2-way valves (one 3-Way valve)
- Most are globe style valves with piston poppets (some barstock direct lift)
- Gravity close, with spring and fluid pressure assist
- Most are in-line mounted full ported using pipe threads
- Many are available either normally open or normally closed
- Built to handle all types of clean fluid including air, water, oil, steam, cryogenics, fuels, caustics, refrigerants, and solvents

#### Performance Ranges

- Pressure: vacuum to 10,000 psi (690 bar)
- Fluid temperatures: -423° F (-253° C) to +500° F (+260° C) [+750° F (+399° C) some models]
- Pipe sizes from 1/8" to 3" (Cv from 0.02 to 71)

#### Materials of Construction

- 316 stainless steel & naval bronze or brass
- Seat material selection:  
Elastomer: Buna N, Viton®, EPR  
Plastic: PTFE, PCTFE  
Metal: stainless, brass

All plunger and magnetic stop materials are electroless nickel-plated 416 or 430 stainless steels. Some AC valves have shading rings made of silver or copper. See [page 21 of the Atkomatic Technical Manual](#) for details

#### Actuators

- Solenoids rated for continuous duty (operational pressure values for normally open valves are based on intermittent duty only)
- Class H and class B available
- Available with NEMA  
Type 1 housing: standard  
Type 4 housings: waterproof  
Type 7 and 9 housings: explosion-proof for hazardous locations

### Circle Seal Controls

2301 Wardlow Circle • P.O. Box 3300 • Corona, CA 92880

Phone (951) 270-6200 Fax (951) 270-6201

www.circlesealcontrols.com • am\_sales@circlesealcontrols.com • ind\_sales@circlesealcontrols.com

# ATKOMATIC Solenoid Valves

## *Catalog Index*

---

Product Line Overview.....	1	7000.....	34
How to Order		8000.....	36
Ordering Valves.....	3	12000.....	39
Ordering Repair Kits.....	3	13000.....	41
Constructing Catalog Numbers.....	4	14000.....	44
Product Matrix.....	6	15400.....	46
Valves Series		15800.....	49
JJ.....	8	16000.....	51
HS.....	10	30400.....	55
15-794.....	12	30800.....	59
500.....	14	35800.....	62
1000.....	18	40000.....	65
2000.....	21	50000.....	68
3000.....	24	Options	
4000 & 5000.....	27	Catalog.....	71
6000.....	31	Project (special).....	72

# ATKOMATIC Solenoid Valves

## *Valve Ordering Information*

ATKOMATIC valves can be ordered from any of the Circle Seal distributors. A complete list of all authorized stocking distributors is on the Internet at <http://www.circle-seal.com>.

There are 3 methods of ordering ATKOMATIC solenoid valves:

- 1 Specifying the current catalog number
- 2 Specifying the complete application information
- 3 For some older valves, referencing a serial number.

### **Method 1: Specifying the current catalog number**

This is the preferred method for ordering solenoid valves.

These catalog numbers are constructed as outlined in the product offering section and more detailed instructions are on pages 4–5. Use of these catalog numbers eliminates the need for communicating lengthy text describing all of the application information. Use of these catalog numbers will facilitate order processing in the factory.

Note that the same application information as described in Method 2 must be obtained from the customer to create the catalog number.

### **Method 2: Specifying the complete application information**

- 1 Valve type: normally open or normally closed. This is the position that the valve will return to when electricity is removed.
- 2 Pilot operated, direct lift of semi-direct lift. This selection can be made by reviewing the customer's application with regard to minimum pressure drop and flow requirements (page 4-5).
- 3 Pipe size. If this is not known, it can be determined from the flow,  $C_v$ , and/or pressure drop requirement obtained from the customer and/or using the formula from the catalog (see page 13 of the Atkomatic Technical Manual).
- 4 Material of construction: bronze or stainless steel. This selection is made considering compatibility with the fluid and sometimes determined by pressure and size requirements.
- 5 Fluid: the exact type and state (gas or liquid). The fluid temperature is required if it is elevated or if the fluid is more viscous than 150 SUS at room temperature or if fluid compatibility is an issue.
- 6 Voltage: both the voltage and frequency (if different from 60 Hz, the assumed default).
- 7 Maximum operating pressure (maximum differential pressure).

Note that this is not necessarily the maximum pressure at which a particular valve series can perform. More often than not, applications require a specific operational capability that is below the maximum operating pressure of the valve series. Specifying the actual operating pressure requirement allows maximizing the overall performance of the valve by appropriate sizing of the valve's internal orifices. Select the pressure category that matches or most closely exceeds the maximum operational requirement for the application.

- 8 Ambient temperature if elevated above normal room temperature 104° F (40° C), the maximum ambient for continuous coil operation).
- 9 Options: valve position indicator, manual opening device, or manual throttling device.

Note: If the 4 or 5 digit catalog base number is already known steps 1 through 4 have already been completed.

### **Method 3: Referencing a serial number**

This may apply when an order is placed to duplicate a previously built ATKOMATIC Solenoid Valve. The serial number is a 6-digit number that appears on the valve's nameplate at the top of the coil housing. Valves produced after July, 1998 are not serialized and this method of ordering is not applicable to them. The factory maintains files of serialized valves built between July, 1990 and July, 1998 and may be able to duplicate these upon order. Due to incomplete records, this is not a recommended method of ordering valves.

Without this information it is not possible to select a valve or accept and process an order.

### **Repair Kits Ordering Information**

To order a repair kit for a valve, specify the valve catalog number preceded by a K\ . For instance the repair kit for a 31820–200PMAA1S valve is K\31820–200PMAA1S. Typical contents of repair kits are shown in the section for each valve series in this catalog.

*NOTE: All ATKOMATIC valves are built exclusively for the type of fluid and pressure indicated on the product nameplate. Attempted usage at higher pressures and/or different fluids can result in immediate or delayed valve malfunction (failure to open or close and/or leakage).*

# Instructions for Creating the Solenoid Valve Catalog Numbers

Note: Not all the categories apply to all valve series (see the catalog numbering key for each valve series in the Product Offering section, pages 7-70).

1 Match the customer's needs to a catalog base number or valve series using the process outlined in steps 1 through 4 of Method 2 (specifying the complete application information) of the previous section.

2 Fill in the first 3 digits after the dash with the appropriate coil voltage code leaving zeros in 2 of the 3 spaces for the unused voltages (see page 3-4 of the Atkomatic Technical Manual).

*Note: The valves are designed to operate reliably with a voltage within  $\pm 10\%$  of the nominal catalog voltage for normally closed valves and  $+10\% - 0\%$  for normally open valves.*

3 Select the coil insulation temperature rating: class H (180° C rise) or class B (155° C rise). Class B coils can be successfully used when fluid temperatures are between 0° and 220° F (-18° C and +104° C) and the ambient is at room temperature. Class H coils are recommended for other ambient and fluid temperature ranges or where maximum coil life is desired. Usage examples for class H coils include cryogenic fluids, steam, and hot locations such as boiler fuel feed. If in doubt, default to class H which, although slightly more expensive, provides the customer a higher degree of coil burnout protection. Note that class H coils are typically used by default on most stainless steel valves and class B coils or class H coils can be specified on the bronze valves (see page 5 of the Atkomatic Technical Manual).

4 Select the connection type. The default is pipe thread (NPT) which is the preference of the majority of industrial customers. British pipe threads are frequently specified for the Japanese market. AND threads, Aminco threads, flanges, tube stubs, pipe stubs, socket welded connections, butt welded connections, and couplings are options that cause the valve to become a project valve that is numbered differently than catalog valves.

5 Select the operating pressure (for pilot operated and semi-direct lift valves) or orifice size (for direct lift valves)\*. This pressure is the actual maximum pressure differential that the valve will be operated at. This can be (and frequently is) less than the maximum possible pressure for a particular valve series (see page 1 of the Atkomatic Technical Manual for an explanation of operational pressure and the individual valve series pressure capabilities in the Product Offering section, pages 7-70).

a) Direct lift valves

The diameter of the flow orifice specified determines the flow capacity or Cv of the valve. Note that as larger orifice sizes are selected, the pressure differential that the valve can open against is decreased. Conversely, increasing the differential pressure across the valve requires the use of a smaller flow orifice and therefore results in a lower flow capacity or Cv. This relationship between operational pressure and flow orifice sizing is displayed on charts in the catalog pages for each valve. Note that the viscosity of the fluid has a significant influence on the operational pressures. This is caused by the viscous drag on the plunger as it moves through the fluid during valve opening. This effect is also displayed in the catalog tables which show different operational pressures for three fluids with different viscosity's (representative fluids for these 3 categories are air, water, and hydraulic oil). The pressures given are the maximum operational differential pressures that the valves can operate reliably with the particular orifice selected.

\* The 50000 Series normally open direct lift valve is an exception to this. The operating pressure range must be known and is specified by the second digit of the catalog number. This is because the construction of the pressure containment changes for pressures above 1500 psi (104 bar).

b) Pilot operated and semi-direct lift valves

The maximum operational differential pressure the valve is built to operate against is specified here. Note that this is not necessarily the maximum pressure at which a particular valve series can perform. More often that not, applications require a specific operational capability that is below the maximum pressure rating of the valve. Specifying this actual pressure requirement allows maximizing the overall performance of the valve by appropriate sizing of the valve's internal orifices. Select the pressure category that matches or most closely exceeds the maximum operational requirement for the application.

6 Select the main seat and pilot seat material(s)

The following is a set of general rules to guide in the selection of seat materials:

a) Select materials that are chemically compatible with the fluid at operational temperatures. This may at first sound difficult but actually is no different than selecting seal material for any other type of product including other Circle Seal components. There are many sources for chemical compatibility data such as:

- 1) The technical section of Circle Seal's catalog.
- 2) Parker's o-ring handbook.
- 3) *Chemical Resistance Guide for Elastomers* by Kenneth Pruett, Compass Publications, P.O. Box 2276, La Mesa, CA 91943, (619) 589-9336

b) Rubber seats (disk & pilot) cannot be used over 500 psig. This is the maximum pressure at which these seals will perform

reliably. Plastic (PTFE or PCTFE) or metal seats must be used for pressures above 500 psi. In full ported valves, a rubber disc seal can be physically displaced by flow forces if exposed to pressure drops exceeding 500 psig. In direct lift valves pressure drops over 500 psi will deform a rubber seat reducing the orifice size and although the valve may still function, flow will be restricted.

- c) Rubber seats (Buna N, Viton®, & EPR) are capable of effecting the most positive seals especially at low pressures. See the factory leakage standards section for the maximum allowable leak rates for production acceptance testing. Typical temperature limitations for rubber seats and seals are:

Buna N: -65° F to +275° F (-54° C to +135° C)

Viton®: -15° F to +400° F (-29° C to +204° C)

EPR: -65° F to +300° F (-54° C to +149° C)

Note that these temperatures are the maximum that the compound can withstand and their suitability with a specific fluid may require more restrictive temperature limitations.

- d) Plastic seats (PTFE & PCTFE) can seal reliably with only moderate leakage at low pressure differentials. See the factory leakage standard section (see page 15 of the Atkomatic Technical Manual) for the maximum allowable leak rates for production acceptance testing. Typical temperature limitations for plastic seats and seals are:

PCTFE: -400° F to +400° F (-240° C to +204° C)

PTFE: -450° F to +500° F (-268° C to +260° C)

Note that these temperatures are the maximum that the compound can withstand and their suitability with a specific fluid may require more restrictive temperature limitations.

- e) Metal seats (brass or stainless steel). Metal pilot seats are commonly used in liquid applications where the fluid does not present a hazard from a flammability or toxic aspect. These applications include most water, oil, liquid nitrogen, etc. applications. The purpose of using metal pilot seats is that the life of the product is enhanced as compared to a rubber or plastic pilot seats. Also the operational pressure capability is increased (the valve is able to operate at higher pressures more reliably) with a slightly increased leakage allowance. Metal disc or main valve seats are typically used where temperature limitations require their use.

#### 7 Select the seal material

Generally, use the same material for the external seals as was used for the valve seats i.e. if Buna N seats are used, then Buna N body seals are also used. (An exception is PCTFE which is not available in o-rings in the standard catalog product). The valve body seal materials are not subject to the 500 psi limitation that the seats; for instance, PTFE disc seats can be used at high pressure with Viton® body seals.

#### 8 Specify the fluid media by type category (see page 1 of the Atkomatic Technical Manual for assistance in selection the fluid category). The categories are:

- a) Gas: this includes all types of fluids that remain in the gaseous state
- b) Low viscosity liquid: all liquid fluids up to a viscosity of 40 SUS (4.3 centistokes) such as water, mineral oil, gasoline, JP-4, #2 diesel & fuel oil, and other light oils depending on their temperature
- c) High viscosity liquid: all liquid fluids from a viscosity of 41 SUS to 150 SUS (32 centistokes) such as light to medium weight oils depending on their temperature (hydraulic fluids such as MIL-5606, #3 & #4 diesel & fuel oil)
- d) Steam
- e) Cryogenic fluids: includes all fluids that can be in either a liquid or gaseous state such as liquid nitrogen, liquid oxygen, liquid hydrogen, liquid argon, CO<sub>2</sub>, etc.

*Note: In cases where the fluid can exist at either a liquid or gaseous state, select a cryogenic make-up regardless of the temperatures involved. An example of this would be butane, which can be a gas or liquid depending on pressure at temperatures at or near room temperature.*

#### 9 Select the coil housing (see pages 8 and 12 of the Atkomatic Technical Manual for coil housing information).

- a) Standard NEMA 1
- b) Waterproof NEMA 4
- c) Explosion-proof NEMA 7
- d) Combination explosion- and waterproof NEMA 4 & 7

#### 10 Specify options desired (available on selected series, see page 71).

- a) valve position indicator
- b) manual opening device
- c) manual metering device

Consult with you local stocking distributor or the sales department at the factory for assistance in selecting and specifying valve products for specific applications.

# Valve Product Matrix

## Configurable Valves for General Applications—valves that are built to order

VALVE TYPE	MATERIAL	PRESSURE	PIPE SIZE	SERIES	PAGE
Direct Lift	Bronze	1000	¾"-1"	3000	24
		1500	¼"-½"	3000	24
	Stainless	3000	¼"-¾"	14000	44
		5000	⅝"-¼"	1000	18
		6000	¼"-1"	16000	51
		10,000	⅝"-½"	2000	21
Pilot-piston	Bronze	300	¼"-1½"	500	14
		500	¼"-1½"	4000	27
		500	2"-3"	5000	27
		1000	¾"-1½"	6000	31
		1500	¼"-½"	6000	31
		3000	⅝"-1"	12000	39
	Stainless	1500	1¼"-2"	8000	36
		4000	¼"-1½"	8000	36
		6000	⅝"-½"	7000	34
		300	¼"-1½"	15400	46
		500	2"-3"	30400	55
		1000	¾"-1½"	30400	55
Semi-direct	Bronze	1500	¼"-½"	30400	55
		1500	¼"-1"	15800	49
		3000	¼"-2"	30800	59
	Stainless	1500	¼"-1"	15800	49
		3000	¼"-2"	30800	59

## Configurable Valves for Special Applications—valves that are built to order

VALVE TYPE	MATERIAL	PRESSURE	PIPE SIZE	SERIES	PAGE
3-Way Direct Lift	Stainless	2500	¼"-½"	13000	41
High Temp Direct Lift	Stainless	2500	⅝"-1"	50000	68
Fast Response Pilot-piston	Stainless	2000	1¼"-2"	35800	62
		1500	½"-1"	35800	62
High Temp Semi-direct	Stainless	2500	¼"-1½"	40000	65

## Specific Purpose Valves—valves that are pre-built for common applications

VALVE TYPE	MATERIAL	PRESSURE	PIPE SIZE	SERIES	PAGE
Steam Pilot-piston	Bronze	125	¼"-1½"	HS	10
Air Water Oil Pilot-piston	Bronze	250	¼"-2"	JJ	8
CO <sub>2</sub> Pilot-piston	Stainless	350	½"	15-794	12

## Explanation of Product Matrix

To facilitate understanding the scope of the ATKOMATIC product line, the valves can be divided into 3 basic valve design categories as follows: 1) Direct lift valves 2) Pilot operated valves 3) Semi-direct lift valves

Each of these basic valve types is appropriate to use in different types of customer's systems.

Direct lift valves are applicable where large flow volumes are not required and pressures range from medium to very high. Because direct lift valves utilize the solenoid force to directly effect the opening of the flow orifice against line pressure, they are restricted to relatively small flow capacities. See page 21 of the Atkomatic Technical Manual for a complete description of operation. Typical line sizes are 1/8" to 3/8" with flow orifices ranging from 0.047 (3/64") to 0.188 (3/16"). Application examples include direct injection of an additive into a process, high pressure cleaning, low volume bleeding operations, high pressure hydraulic systems, etc.

Pilot operated valves are used where a flow producing a minimum pressure drop is always present in a system or in systems where the valves full flow capacity is not required under low flow conditions. The solenoid in these valves is used to open a small internal pilot orifice that unbalances the valves piston thus opening a relatively large flow area. See pages 21-23 of the Atkomatic Technical Manual for a complete description of operation. A pressure differential of 5 psi minimum is required to open (and maintain open) these types of valves. Sizes are available from ¼" to 3" and are fully ported (internal flow areas are equal to or greater than the connecting pipe). Application examples include container filling, chemical process, fluid transfer in systems where flow is constant, etc.

Semi-direct lift valves are utilized where it is desired to have the valve function independent of system flow (operation down to 0 psi or where flow may not be sufficient to produce a 5 psi differential across the valve). These valves function in a similar manner to pilot operated valves but have a mechanical linkage between the piston and the solenoid plunger that holds the valve open. See page 22 of the Atkomatic Technical Manual for a complete description of operation. Semi-direct lift valves are available in line sizes of ¼" to 3" and are also fully ported. Application examples include tank venting to atmospheric pressure or 0 psi, charging a tank to a pressure equal to supply pressure, processes where flow is variable and might be insufficient to provide a 5 psi differential, vacuum systems, pump inlet lines, etc.

Within each of these categories are valves of 2 basic materials of construction: bronze and stainless steel, each serving different fluid media. In addition, the pressure capabilities vary with different valve series within each of the design type categories and material of construction subcategory.

Most of the valves in the product line are configurable, meaning that they can be constructed to meet a variety of application conditions by varying their internal components.

# Explanation of Product Matrix

The configurable valve series are:

## Direct Lift Design

### Bronze

3000 Series, 0 to 1500 psi (0 to 104 bar)

### Stainless

14000 Series, 0 to 3000 psi (0 to 207 bar)  
 1000 Series, 0 to 5000 psi (0 to 345 bar)  
 16000 Series, 0 to 6000 psi (0 to 414 bar)  
 2000 Series, 0 to 10,000 psi (0 to 690 bar)

## Pilot-piston Design

### Bronze

500 Series, 5 to 300 psi (0.4 to 10.4 bar)  
 4000 Series, 5 to 500 psi (0.4 to 35.4 bar)  
 5000 Series, 5 to 500 psi, 2 to 3" sizes (0.4 to 34.5 bar)  
 6000 Series, 5 to 1500 psi (0.4 to 104 bar)  
 12000 Series, 5 to 3000 psi (0.4 to 207 bar)

### Stainless

8000 Series, 5 to 4000 psi (0.4 to 34.5 bar)  
 7000 Series, 5 to 6000 psi (0.4 to 414 bar)

## Semi-direct Lift Design

### Bronze

15400 Series, 0 to 300 psi (0 to 10.4 bar)  
 30400 Series, 0 to 1500 psi (0 to 104 bar)

### Stainless

15800 Series, 0 to 1500 psi (0 to 104 bar)  
 30800 Series, 0 to 3000 psi (0 to 207 bar)

There are some valves that do not fit neatly into this progression that address specific marketplace needs. These valves are also configurable and include:

13000 Direct Lift 3-Way Valve, stainless steel, 0 to 2500 psig (0 to 173 bar)  
 35000 External Pilot Operated, stainless steel, 0 to 2000 psig (0 to 138 bar), rapid closure  
 40000 Semi-direct Lift, stainless steel, 0 to 2500 psig (0 to 173 bar), elevated media temperatures to 750° F (399° C)  
 50000 Direct Lift, stainless steel, 0 to 3000 psig (0 to 207 bar), elevated media temperatures to 750° F (399° C)

A few of the valves are designed to meet specific usage's and are always built with the same configuration of internal parts.

The specific usage valves are currently: JJ Series, general purpose air, water, and oil, 5 to 250 psig  
 HS Series, steam, 5 to 125 psi  
 15-794 Series, liquid CO<sub>2</sub>, 5 to 350 psi

All of these valves are currently pilot-piston operated. They are designed to cover specific and/or broad ranges of applications such that they can be conveniently stocked by distribution for rapid delivery.

These specific usage valves may be added to or removed as the demand for them changes.

These valve series are available in either normally open or normally closed configurations.

SERIES	NORMALLY CLOSED	NORMALLY OPEN	PAGE
	CATALOG NUMBER PREFIX	CATALOG NUMBER PREFIX	
500	5x0	5x1	14
3000	3x00 & 3x08	3x01	24
4000	4x00 & 4x08	4x01 & 4x07	27
5000	5x00 & 5x08	5x01 & 5x07	27
6000	6x00	6x01	31
8000	8xx0	8xx1	36
13000*	131x0	132x0	41
15400	154x0 & 154x8	154x1 & 154x7	46
16000	16x00	16x01	51
30400	314x0	324x0	55
30800	318x0 & 318x1	328x0 & 328x1	59
35800	358xx-O	358xx-P	62
40000	418x0	428x0	65
50000	50xx0	50xx1	68

### Notes:

1. The pressures given above are the maximum for the various valve series, actual operating pressure will vary with coil voltages and fluid media (and in some cases valve size).
2. Normally open valves are rated for intermittent duty only unless other operational parameters (such as voltage, ambient temperature, fluid temperature, etc.) are at their nominal values.

\* The 13000 Series is also available in a distributor version which has a catalog number prefix of 133x0 and is described on page 49.



# ATKOMATIC

## JJ Series

Bronze, Pilot-piston, Pressure 5 to 250 psig (0.4 to 17 bar)  
General Purpose Air, Water, and Light Oil (150 SSU max.) Value



### Features

- Pressures to 250 psig (17 bar)
- Fluid temperatures from  $-65^{\circ}\text{F}$  to  $+180^{\circ}\text{F}$  ( $-54^{\circ}\text{C}$  to  $+82^{\circ}\text{C}$ )
- Pipe sizes from  $\frac{1}{4}$ " through 2" (British BSPT ports available)
- Full ported valves: Cv from 1.4 to 46
- Pilot operated: require a minimum pressure differential of 5 psig
- Bronze or brass valve material
- Buna N pilot seat, piston seat, and body o-ring seals
- Class B and class H coils are available
- Coil housing - Nema 1
- Treated 416 stainless steel plunger material for increased corrosion resistance

### Operational Pressures (5 psid minimum pressure differential)

GASES		LIQUIDS TO 40 SUS		LIQUIDS OVER 40 SUS	
AC	DC	AC	DC	AC	DC
250	150	150	100	75	50

### Circle Seal Controls

2301 Wardlow Circle • P.O. Box 3300 • Corona, CA 92880

Phone (951) 270-6200 Fax (951) 270-6201

www.circlesealcontrols.com • am\_sales@circlesealcontrols.com • ind\_sales@circlesealcontrols.com

atkomatic solenoid

# JJ Series

## Dimensions, Shipping Weights, and Cv Flow Factors

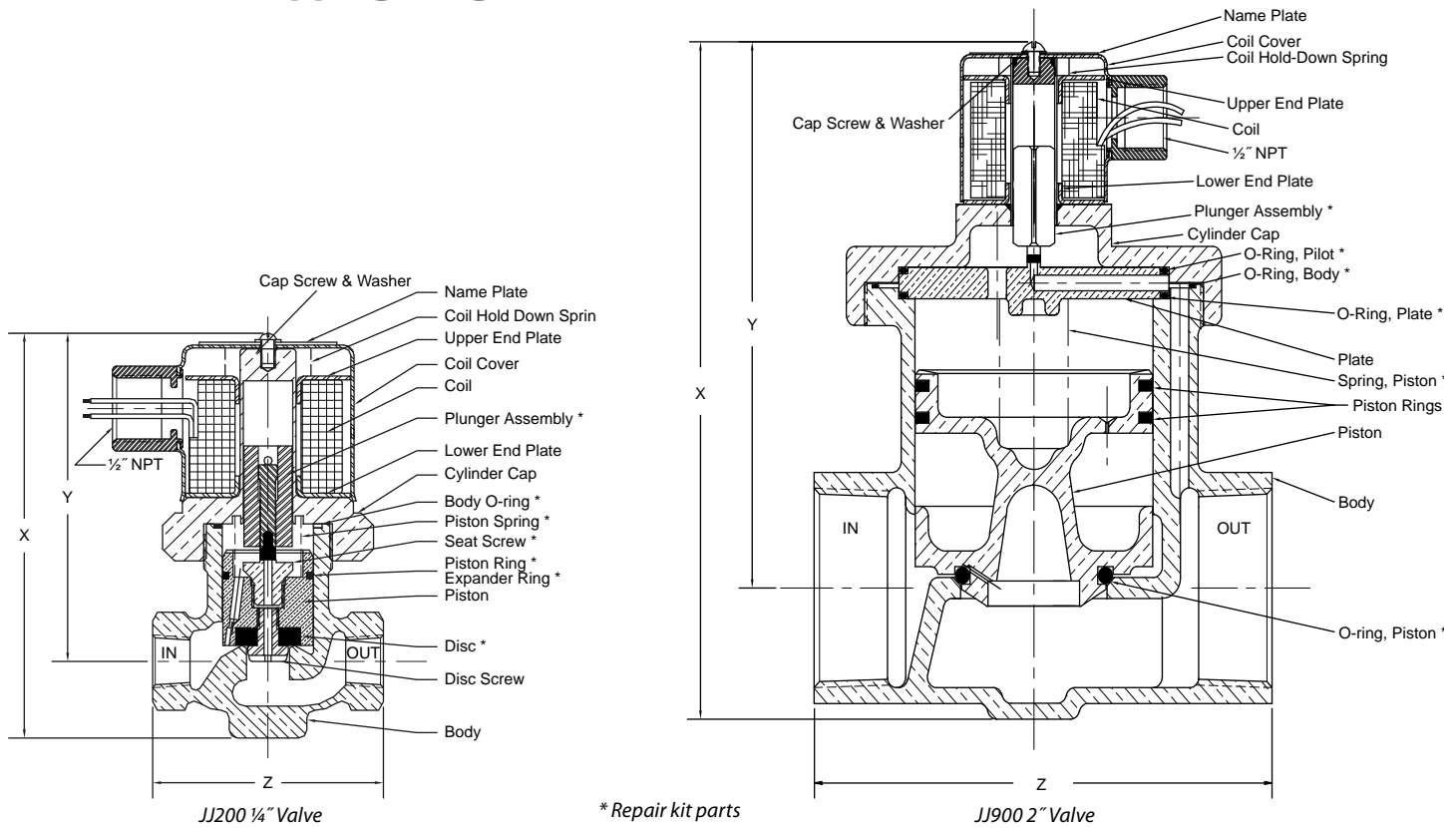

CATALOG NUM. PREFIX	PIPE SIZE	MAIN SEAT ORIFICE DIA.	X	Y	Z	SHIPPING WEIGHT (lbs)	Cv
JJ200	1/4"	1/2"	4 3/4"	3 7/8"	2 1/16"	3	1.4
JJ300	3/8"	1/2"	4 3/4"	3 7/8"	2 1/16"	3	2.7
JJ400	1/2"	1/2"	4 3/4"	3 7/8"	3"	4	3.5
JJ500	3/4"	1"	5 1/4"	4"	3 3/4"	5	7.5
JJ600	1"	1"	5 1/4"	4"	3 3/4"	5	9.1
JJ700	1 1/4"	1 1/2"	7"	5 1/8"	5 1/8"	13	19.5
JJ800	1 1/2"	1 1/2"	7"	5 1/8"	5 1/8"	13	21.0
JJ900	2"	2"	8 1/2"	6 1/2"	6 1/4"	16	46.0

## How to Order

**JJ** *x* **00** - *x* *x* *x* *x*

**CONNECTION SIZES**

<b>2</b> 1/4"	<b>6</b> 1"
<b>3</b> 3/8"	<b>7</b> 1 1/4"
<b>4</b> 1/2"	<b>8</b> 1 1/2"
<b>5</b> 3/4"	<b>9</b> 2"

**VOLTAGE AC/60 Hz**

<b>0</b> DC voltage	<b>5</b> 230-60 VAC
<b>1</b> 24-60 VAC	<b>6</b> 460-60 VAC
<b>2</b> 100-60 VAC	<b>7</b> 110-50 VAC
<b>3</b> 115-60 VAC	<b>8</b> 220-50 VAC
<b>4</b> 200-60 VAC	<b>9</b> 380-50 VAC

**CONNECTION TYPE**

**P** NPT

**COIL INSULATION RATING**

**B** Class B 155° C

**H** Class H 180° C

**VOLTAGE DC**

**0** AC voltage

**1** 12 VDC

**2** 24 & 32 VDC

**3** 48 VDC

**4** 100 VDC

**5** 125 VDC

**6** 250 VDC

# ATKOMATIC

## HS Series

Bronze, Pilot-piston, Pressure 5 to 125 psig (0.4 to 9 bar)  
Steam or Hot Water Value



### Features

- Pressures to 125 psig (9 bar) saturated steam temperature of 352° F (178° C)
- Pipe sizes from ¼" through 1½" (British BSPT ports available)
- Full ported valves: Cv from 1.4 to 21
- Pilot operated: require a minimum pressure differential of 5 psig (0.4 bar)
- Bronze valve material (naval M Bronze)
- Metal to metal pilot seat, PTFE piston seat and PTFE body o-ring seal
- Class H coil is standard
- Treated 416 stainless steel plunger material for increased corrosion resistance
- No other options available

### Operational Pressures (5 psid minimum pressure differential)

LIQUIDS TO 40 SUS		STEAM	
AC	DC	AC	DC
125	125	125	125

### Circle Seal Controls

2301 Wardlow Circle • P.O. Box 3300 • Corona, CA 92880

Phone (951) 270-6200 Fax (951) 270-6201

www.circlesealcontrols.com • am\_sales@circlesealcontrols.com • ind\_sales@circlesealcontrols.com

atkomatic solenoid

# HS Series

## Dimensions, Shipping Weights, and Cv Flow Factors

CATALOG NUM. PREFIX	PIPE SIZE	MAIN SEAT ORIFICE DIA.	X	Y	Z	SHIPPING WEIGHT (lbs)	Cv
HS200	1/4"	1/2"	4 3/4"	3 7/8"	2 1/16"	3	1.4
HS300	3/8"	1/2"	4 3/4"	3 7/8"	2 1/16"	3	2.7
HS400	1/2"	1/2"	4 3/4"	3 7/8"	3"	4	3.5
HS500	3/4"	1"	5 1/4"	4"	3 3/4"	5	7.5
HS600	1"	1"	5 1/4"	4"	3 3/4"	5	9.1
HS700	1 1/4"	1 1/2"	7"	5 1/8"	5 1/16"	13	19.5
HS800	1 1/2"	1 1/2"	7"	5 1/8"	5 1/16"	13	21.0

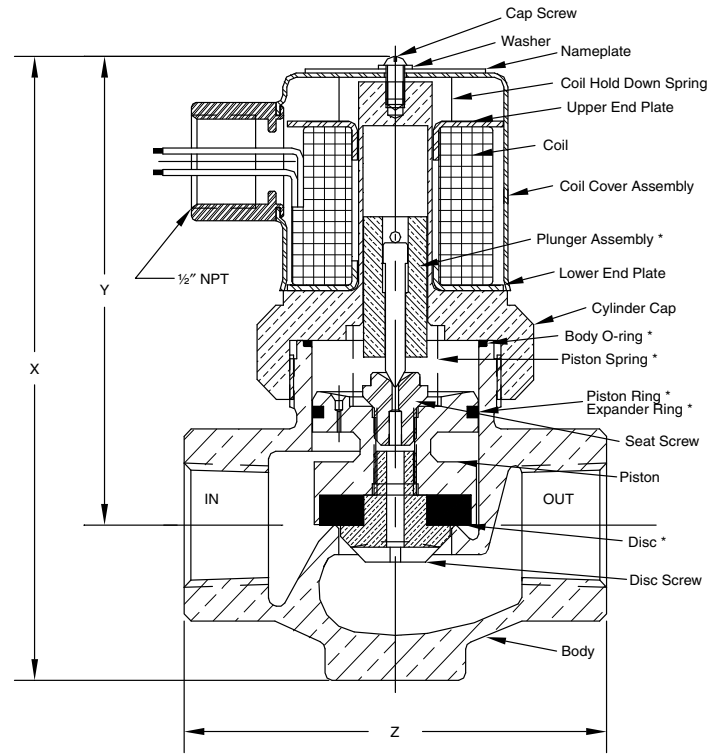

\* Repair kit parts

## How to Order

**HS** *x* **00** - *x* *x* *x*

### PIPE THREAD SIZES

- |               |                 |
|---------------|-----------------|
| <b>2</b> 1/4" | <b>6</b> 1"     |
| <b>3</b> 3/8" | <b>7</b> 1 1/4" |
| <b>4</b> 1/2" | <b>8</b> 1 1/2" |
| <b>5</b> 3/4" |                 |

### VOLTAGE AC

- |                     |                     |
|---------------------|---------------------|
| <b>0</b> DC voltage | <b>5</b> 230-60 VAC |
| <b>1</b> 24-60 VAC  | <b>6</b> 460-60 VAC |
| <b>2</b> 100-60 VAC | <b>7</b> 110-50 VAC |
| <b>3</b> 115-60 VAC | <b>8</b> 220-50 VAC |
| <b>4</b> 200-60 VAC | <b>9</b> 380-50 VAC |

### CONNECTION TYPE

- P** NPT
- J** British pipe thread

### VOLTAGE DC

- 0** AC voltage
- 1** 12 VDC
- 2** 24 & 32 VDC
- 3** 48 VDC
- 4** 100 VDC
- 5** 125 VDC
- 6** 250 VDC

# ATKOMATIC

## 15-794 Series

Stainless Steel, Pilot-piston, Pressure 5 to 350 psig (.4 to 24 bar)  
Liquid CO<sub>2</sub> Valve



### Features

- Designed specifically for liquid CO<sub>2</sub>
- Pilot operated valve
- Pressure to 350 psig (24 bar)
- 1/2" NPT ports
- Cv of 3.0
- Stainless steel construction
- PTFE piston (seat material)
- PTFE body seal
- Coil housing is waterproof and nickel plated
- Class H and Class B coils are available
- No other options available

### Operational Pressures (5 psid minimum pressure differential)

#### LIQUID CARBON DIOXIDE

AC	DC
350	350

atkomatic solenoid

### Circle Seal Controls

2301 Wardlow Circle • P.O. Box 3300 • Corona, CA 92880

Phone (951) 270-6200 Fax (951) 270-6201

www.circlesealcontrols.com • am\_sales@circlesealcontrols.com • ind\_sales@circlesealcontrols.com

# 15-794 Series

## Dimensions, Shipping Weights, and Cv Flow Factors

CATALOG NUM. PREFIX	PIPE SIZE	X	Y	Z	SHIPPING WEIGHT (lbs)	Cv
15-794	1/2"	5 1/4"	3 3/8"	2 3/8"	4	3

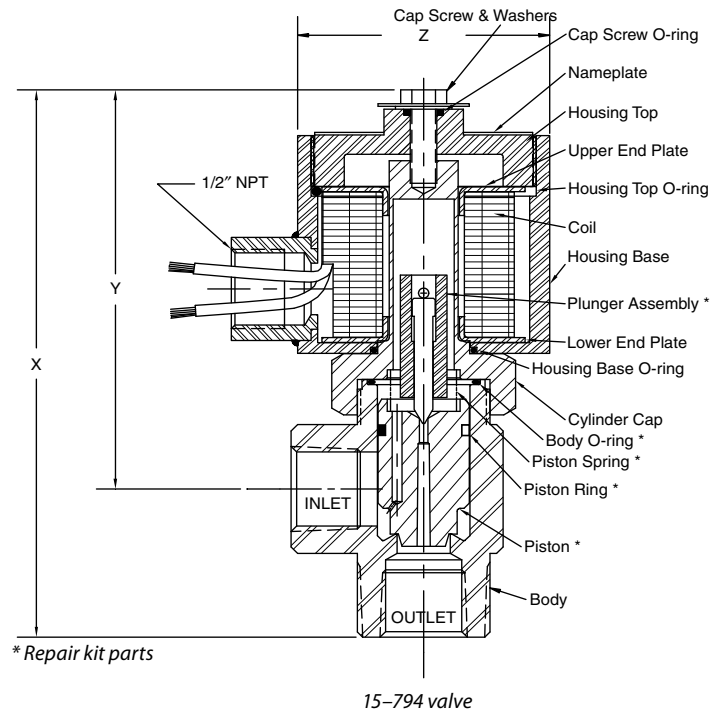

## How to Order

**15-794 -** x x x x

### VOLTAGE AC/60 Hz

- |                     |                     |
|---------------------|---------------------|
| <b>0</b> DC voltage | <b>5</b> 230-60 VAC |
| <b>1</b> 24-60 VAC  | <b>6</b> 460-60 VAC |
| <b>2</b> 100-60 VAC | <b>7</b> 110-50 VAC |
| <b>3</b> 115-60 VAC | <b>8</b> 220-50 VAC |
| <b>4</b> 200-60 VAC | <b>9</b> 380-50 VAC |

### CONNECTION TYPE

- P** NPT
- J** British pipe thread

### COIL INSULATION RATING

- B** Class B 155° C
- H** Class H 188° C

### VOLTAGE DC

- 0** AC voltage
- 1** 12 VDC
- 2** 24 & 32 VDC
- 3** 48 VDC
- 4** 100 VDC
- 5** 125 VDC
- 6** 250 VDC

# ATKOMATIC

## 500 Series

Bronze, Pilot-piston, Pressure 5 to 300 psig (0.4 to 21 bar)  
Low Pressure Valve Configurable for Variety of Fluid Applications



### Features

- Pressures to 300 psig (21 bar)
- Fluid temperatures from  $-100^{\circ}\text{F}$  to  $+450^{\circ}\text{F}$  ( $-73^{\circ}\text{C}$  to  $+232^{\circ}\text{C}$ )
- For use with any gas or liquid (max. viscosity of 150 SUS), including steam, that is not harmful to bronze
- Pipe sizes from  $\frac{1}{4}$ " through  $1\frac{1}{2}$ " NPT (British BSPT ports available)
- Full ported valves: Cv from 1.4 to 21
- Pilot operated: requires a minimum pressure differential of 5 psig
- Available in normally open and normally closed versions
- Optional pilot and piston seat materials of PTFE, PCTFE, Buna N, Viton®, EPR, or metal (316 stainless steel pilot and/or brass piston seat) depending on fluid type and pressure
- Body seal materials of PTFE, Viton®, Buna N, or EPR.
- Bronze valve material (naval M Bronze)
- Coil housings available in NEMA 1 (standard), NEMA 4 (waterproof), NEMA 7 (explosion-proof for hazardous locations), and combination NEMA 4 & 7
- Manual opening and throttling devices are available as options
- Class B coils are available for media temperatures of  $0^{\circ}\text{F}$  through  $+220^{\circ}\text{F}$  ( $-18^{\circ}\text{C}$  through  $+104^{\circ}\text{C}$ )
- Class H coils are available: recommended for media temperatures of  $-100^{\circ}\text{F}$  through  $+450^{\circ}\text{F}$  ( $-73^{\circ}\text{C}$  through  $+232^{\circ}\text{C}$ )
- Treated 416 stainless steel plunger material for increased corrosion resistance

### Circle Seal Controls

2301 Wardlow Circle • P.O. Box 3300 • Corona, CA 92880

Phone (951) 270-6200 Fax (951) 270-6201

www.circlesealcontrols.com • am\_sales@circlesealcontrols.com • ind\_sales@circlesealcontrols.com

atkomatic solenoid

# 500 Series

## Operational Pressures (5 psid minimum pressure differential)

Normally Closed 500–560 ¼”–1½”

GASES		LIQUIDS TO 40 SUS		LIQUIDS OVER 40 SUS		STEAM	
AC	DC	AC	DC	AC	DC	AC	DC
300	300	300	300	300	100	125	125

Normally Open 501–561 ¼”–1½”

GASES		LIQUIDS TO 40 SUS		LIQUIDS OVER 40 SUS		STEAM	
AC	DC	AC	DC	AC	DC	AC	DC
300	300	200	200	100	100	125	125

NOTE: Normally open valves are rated for intermittent duty only on 500 Series valves and are not recommended for cryogenic service.

## Dimensions, Shipping Weights, and Cv Flow Factors

### Normally Closed

CATALOG NUM. PREFIX		PIPE SIZE	MAIN SEAT ORIFICE DIA.	X	Y	Z	SHIPPING WEIGHT (lbs)	Cv
N.C.	N.O.							
500	501	¼”	½”	4¾”	3⅞”	2⅞”	3	1.4
510	511	⅜”	½”	4¾”	3⅞”	2⅞”	3	2.7
520	521	½”	½”	4¾”	3⅞”	3”	4	3.5
530	531	¾”	1”	5¼”	4”	3¾”	5	7.5
540	541	1”	1”	5¼”	4”	3¾”	5	9.1
550	551	1¼”	1½”	7”	5⅞”	5⅞”	13	19.5
560	561	1½”	1½”	7”	5⅞”	5⅞”	13	21.0

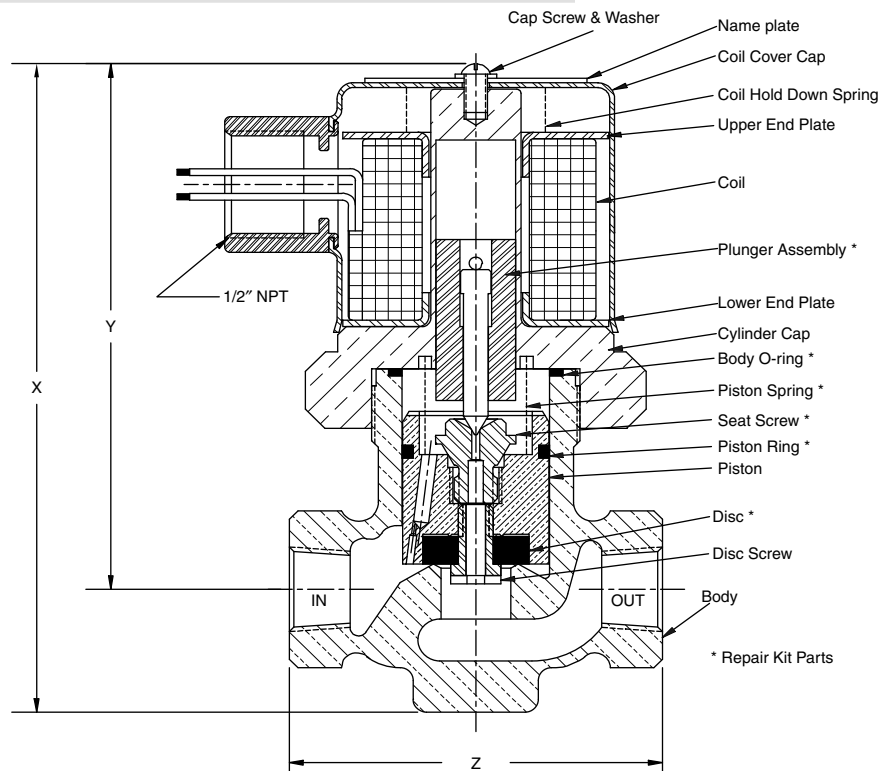

Normally closed ¼” 500 Valve: shown with a standard NEMA 1 coil housing and a metal pilot seat



# 500 Series

## Dimensions, Shipping Weights, and Cv Flow Factors

### Normally Open

CATALOG NUM. PREFIX		PIPE SIZE	MAIN SEAT ORIFICE DIA.	DIMENSIONS			SHIPPING WEIGHT (lbs)	Cv
N.C.	N.O.			X	Y	Z		
500	501	1/4"	1/2"	5 3/4"	4 13/16"	2 1/16"	3	1.4
510	511	3/8"	1/2"	5 3/4"	4 13/16"	2 1/16"	3	2.7
520	521	1/2"	1/2"	5 3/4"	4 13/16"	3"	4	3.5
530	531	3/4"	1"	6 1/8"	4 7/8"	3 3/4"	5	7.5
540	541	1"	1"	6 1/8"	4 7/8"	3 3/4"	5	9.1
550	551	1 1/4"	1 1/2"	8"	6"	5 1/8"	13	19.5
560	561	1 1/2"	1 1/2"	8"	6"	5 1/8"	13	21.0

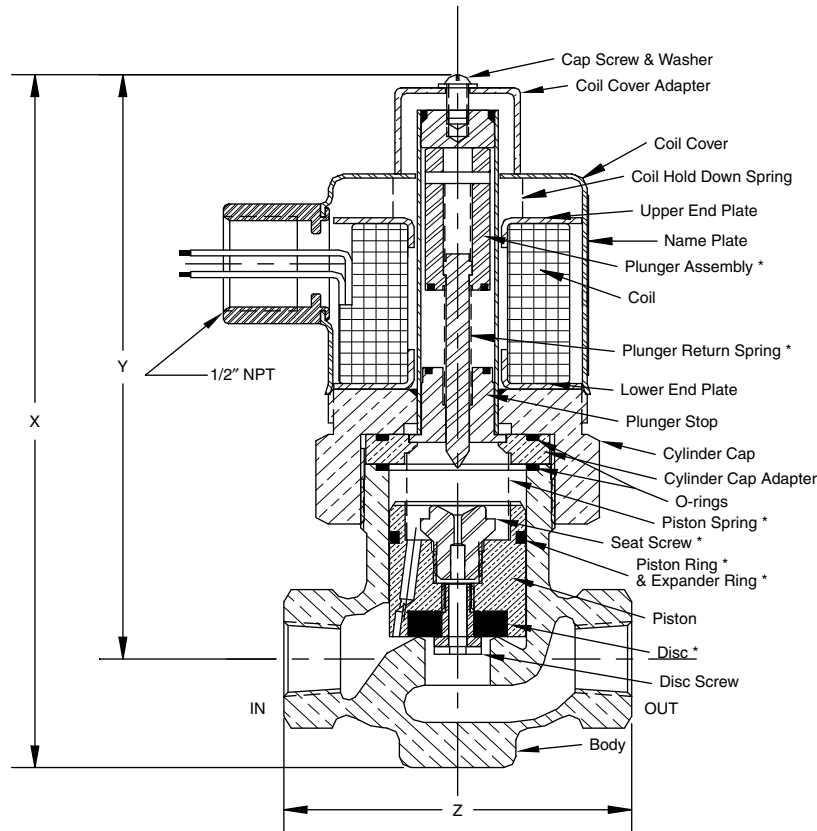

\* Repair kit parts

Normally open 1/4" 501 Valve: shown with a standard NEMA 1 coil housing and metal pilot seat.

# 500 Series

## How to Order

5 x x - x x x x x x x x x x x

### CONNECTION SIZES

- |        |          |          |
|--------|----------|----------|
| 0 1/4" | 3 3/4"   | 6 1 1/2" |
| 1 3/8" | 4 1"     |          |
| 2 1/2" | 5 1 1/4" |          |

### NORMAL (DE-ENERGIZED) POSITION OF VALVE

- 0 Normally closed
- 1 Normally open

### VOLTAGE AC

- |              |              |
|--------------|--------------|
| 0 DC voltage | 5 230-60 VAC |
| 1 24-60 VAC  | 6 460-60 VAC |
| 2 100-60 VAC | 7 110-50 VAC |
| 3 115-60 VAC | 8 220-50 VAC |
| 4 200-60 VAC | 9 380-50 VAC |

### VOLTAGE DC

- |               |           |
|---------------|-----------|
| 0 AC voltage  | 4 100 VDC |
| 1 12 VDC      | 5 125 VDC |
| 2 24 & 32 VDC | 6 250 VDC |
| 3 48 VDC      |           |

### COIL INSULATION RATING

- B Class B
- H Class H

### CONNECTION TYPE

- P NPT
- J British pipe thread

### MAX. OPERATING PRESSURE (psig)

- |      |       |       |
|------|-------|-------|
| A 20 | E 75  | I 200 |
| B 25 | F 100 | J 250 |
| C 50 | G 125 | K 275 |
| D 60 | H 150 | L 300 |

### OPTIONS

- M Manual opening
- T Manual throttling device

### COIL HOUSING

- E Explosion-proof
- S Standard
- W Waterproof
- C Combined water- & explosion-proof

### FLUID MEDIA TYPE

- 1 Gas
- 2 Liquid up to 40 SUS
- 3 Liquid from 41 SUS to 150 SUS
- 4 Steam
- 5 Cryogenic

### SEAL MATERIAL

- |          |          |
|----------|----------|
| A PTFE   | B Buna N |
| C Viton® | D EPR    |

### SEAT/PILOT MATERIAL

- A TFE pilot & TFE disc
- B Buna pilot & Buna disc
- C Viton® pilot & Viton® disc
- D EPR pilot & EPR disc
- E PCTFE pilot & PCTFE disc
- F Metal pilot & Metal disc
- G Metal pilot & TFE disc
- H Metal pilot & Buna disc
- I Metal pilot & Viton® disc
- J Metal pilot & EPR disc
- L Metal pilot & PCTFE disc

# ATKOMATIC

## 1000 Series

Stainless Steel, Direct Lift to 5000 psig (345 bar)  
Medium Pressure Valve Configurable for Variety of Fluid Applications



### Features

- |  |  |
|--|--|
| • Direct acting valve  | • Optional seat materials of PTFE, PCTFE, Buna N, Viton®, EPR, or 316 stainless steel depending on fluid type and pressure                     |
| • Pressure to 5000 psig (345 bar) depending on fluid and orifice size  | • Body seal materials of PTFE, Viton®, Buna N, or EPR.   |
| • Barstock body construction   | • Flow orifice sizes of $\frac{1}{16}$ ", $\frac{3}{32}$ ", $\frac{1}{8}$ ", and $\frac{3}{16}$ "  |
| • Compact size   | • Pipe sizes of $\frac{1}{8}$ " and $\frac{1}{4}$ " NPT  |
| • Stainless steel construction on all wetted parts: 316 for pressure containing parts and plunger material is 416 stainless that is treated for increased corrosion resistance | • British BSPT ports available   |
| • Will handle fluids with viscosity up to 200 SUS  | • Cv from 0.093 to 0.72  |
| • Fluid temperatures from $-423^{\circ}$ F to $+500^{\circ}$ F ( $-253^{\circ}$ C to $+260^{\circ}$ C)   | • Class H coil is standard   |
| • Suitable for use with wide variety of fluid including: air, gasses, liquids, hydraulic fluids, steam, cryogenic fluids, and corrosive fluids                                 | • Can use a class H double wound coil (requires use with a relay to drop put primary coil winding after valve actuation) depending on pressure |
|  | • Coil housing is NEMA 1   |

### Circle Seal Controls

2301 Wardlow Circle • P.O. Box 3300 • Corona, CA 92880

Phone (951) 270-6200 Fax (951) 270-6201

www.circlesealcontrols.com • am\_sales@circlesealcontrols.com • ind\_sales@circlesealcontrols.com

atkomatic solenoid

# 1000 Series

## Operational pressures (No minimum pressure differential)

### Single Wound Coils—Series 1000–1100 Metal Seats

ORIFICE SIZE	GASES		LIQUIDS TO 40 SUS		LIQUIDS OVER 40 SUS		STEAM	
	AC	DC	AC	DC	AC	DC	AC	DC
1/16	2500	1500	1,800	1000	1500	500	300	300
3/32	1000	500	800	350	500	170	300	300
1/8	500	200	400	125	250	50	300	125
3/16	175	55	125	35	125	15	125	35

### Single Wound Coils—Series 1002–1102 Soft Seats (Buna N, Viton®, EPR, PTFE, and PCTFE)

ORIFICE SIZE	GASES		LIQUIDS TO 40 SUS		LIQUIDS OVER 40 SUS		STEAM	
	AC	DC	AC	DC	AC	DC	AC	DC
1/16	2500	1,275	1500	765	1500	500	300	300
3/32	1000	425	675	300	425	150	300	300
1/8	425	170	350	100	200	40	300	100
3/16	150	40	100	30	100	12	110	30

### Double Wound Coils—Series 1004–1104 Metal Seats

ORIFICE SIZE	GASES		LIQUIDS TO 40 SUS		LIQUIDS OVER 40 SUS		STEAM	
	AC	DC	AC	DC	AC	DC	AC	DC
1/16	5000	5000	5000	3500	5000	2500	300	300
3/32	3500	2000	3000	1500	3000	1000	300	300
1/8	2000	800	1500	600	1,200	500	300	300

### Double Wound Coils—Series 1009–1109 Soft Seats (Buna N, Viton®, EPR, PTFE, and PCTFE)

ORIFICE SIZE	GASES		LIQUIDS TO 40 SUS		LIQUIDS OVER 40 SUS		STEAM	
	AC	DC	AC	DC	AC	DC	AC	DC
1/16	5000	4000	4500	3000	4,250	2,100	300	300
3/32	3500	2000	3000	1500	3000	1000	300	300
1/8	2000	800	1500	600	1,200	500	300	300

Note: Buna N, Viton® and EPR seats are limited to 500 psi (34.5 bar)

## Dimensions and Shipping Weights

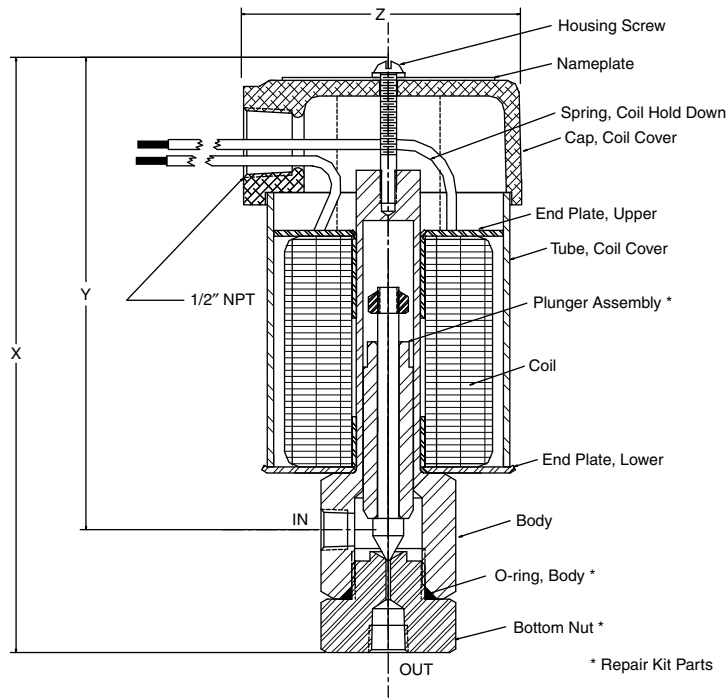

1002 1/8" valve, shown with NEMA 1 coil housing and metal seat

CATALOG NUM. PREFIX				PIPE SIZE	X	Y	Z	SHIPPING WEIGHT (lbs)
SINGLE WOUND COIL, METAL SEAT	SINGLE WOUND COIL, SOFT SEAT	DOUBLE WOUND COIL, METAL SEAT	DOUBLE WOUND COIL, SOFT SEAT					
1000	1002	1004	1009	1/8"	5 3/4"	4 5/8"	2 3/4"	5
1100	1102	1104	1109	1/4"	5 3/4"	4 5/8"	2 3/4"	5

### Cv Flow Factors

ORIFICE SIZE	Cv
1/16	0.093
3/32	0.22
1/8	0.44
3/16	0.72

# 1000 Series

## How to Order

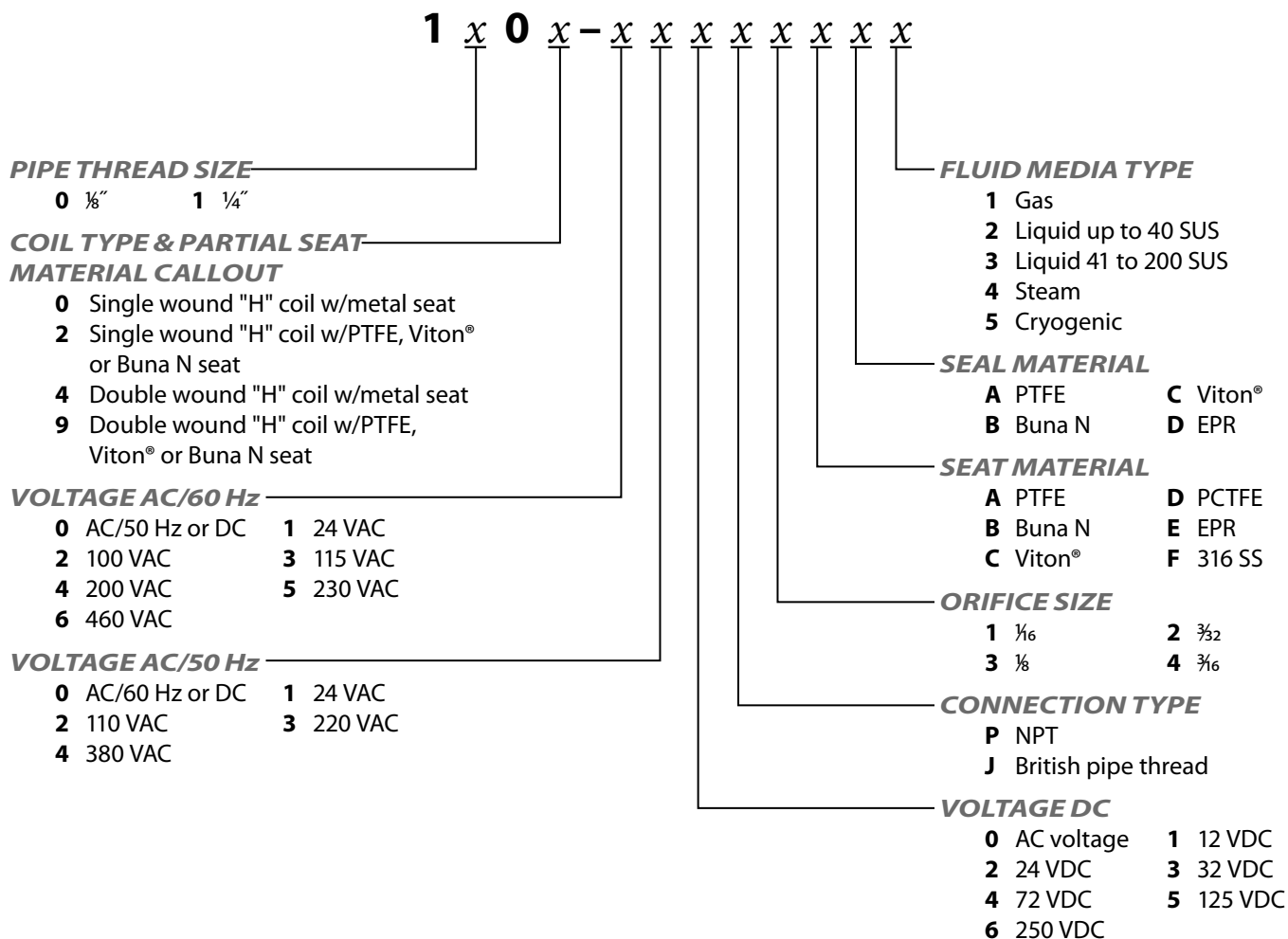

Viton® is a registered trademark of DuPont Dow Elastomers.

# ATKOMATIC

## 2000 Series

Stainless Steel, Direct Lift to 10,000 psig (690 bar)  
Medium Pressure Valve Configurable for Variety of Fluid Applications



atkomatic solenoid

### Features

- Direct acting valve
- Pressure to 10,000 psig (690 bar) depending on fluid and orifice size
- Barstock body construction
- Stainless steel construction on all wetted parts: 316 for pressure containing parts and plunger material is 416 stainless that is treated for increased corrosion resistance
- Will handle fluids with viscosity up to 200 SUS
- Fluid temperatures from  $-423^{\circ}$  to  $+500^{\circ}$  F ( $-253^{\circ}$  C to  $260^{\circ}$  C)
- Suitable for use with wide variety of fluid including: air, gasses, liquids, hydraulic fluids, steam, cryogenic fluids, and corrosive fluids
- Optional seat materials of PTFE, PCTFE, Buna N, Viton<sup>®</sup>, EPR, or 316 stainless steel depending on fluid type and pressure. These are available with  $\frac{1}{16}$ " through  $\frac{3}{16}$ " orifices
- Seat material is Stellite<sup>®</sup> with  $\frac{1}{32}$ " and  $\frac{3}{64}$ " orifices
- Body seal materials of PTFE, Viton<sup>®</sup>, Buna N, or EPR.
- Flow orifice sizes of  $\frac{1}{32}$ ",  $\frac{3}{64}$ ",  $\frac{1}{16}$ ",  $\frac{3}{32}$ ",  $\frac{1}{8}$ ", and  $\frac{3}{16}$ "
- Pipe sizes of  $\frac{1}{8}$ ",  $\frac{1}{4}$ ",  $\frac{3}{8}$ ", and  $\frac{1}{2}$ " NPT
- British BSPT, AND, and AMINCO ports available
- Cv from 0.020 to 0.72
- Can use a class H double wound coil (requires use with a relay to drop put primary coil winding after valve actuation) depending on pressure
- Coil housings available in NEMA 1 (standard), NEMA 4 (waterproof), NEMA 7 (explosion-proof for hazardous locations), and combination NEMA 4 & 7
- Class H coil is standard

### Circle Seal Controls

2301 Wardlow Circle • P.O. Box 3300 • Corona, CA 92880

Phone (951) 270-6200 Fax (951) 270-6201

www.circlesealcontrols.com • am\_sales@circlesealcontrols.com • ind\_sales@circlesealcontrols.com

# 2000 Series

## Operational Pressures (No minimum pressure differential)

### Single Wound Coils—Series 2000–2300 Metal (Stellite®) Seats

ORIFICE SIZE	GASES		LIQUIDS TO 40 SUS		LIQUIDS OVER 40 SUS		STEAM	
	AC	DC	AC	DC	AC	DC	AC	DC
½	8,000	3000	8,000	3000	6000	2000	300	300
¾	3500	1,800	3500	1000	3000	750	300	300

### Single Wound Coils—Series 2000–2300 Metal Seats

ORIFICE SIZE	GASES		LIQUIDS TO 40 SUS		LIQUIDS OVER 40 SUS		STEAM	
	AC	DC	AC	DC	AC	DC	AC	DC
⅙	2500	1500	1,800	1000	1500	500	300	300
⅓	1000	500	800	350	500	170	300	300
½	500	200	400	125	250	60	300	125
¾	175	55	125	35	125	15	125	35

### Single Wound Coils—Series 2000–2300 Soft Seats (Buna N, Viton®, EPR, PTFE, and PCTFE)

ORIFICE SIZE	GASES		LIQUIDS TO 40 SUS		LIQUIDS OVER 40 SUS		STEAM	
	AC	DC	AC	DC	AC	DC	AC	DC
⅙	2500	1,275	1500	765	1500	500	300	300
⅓	850	425	675	300	425	150	300	200
½	425	170	350	100	200	50	300	100
¾	150	40	100	30	100	17	110	30

### Double Wound Coils—Series 2004–2304 Metal (Stellite®) Seats

ORIFICE SIZE	GASES		LIQUIDS TO 40 SUS		LIQUIDS OVER 40 SUS		STEAM	
	AC	DC	AC	DC	AC	DC	AC	DC
½	10,000	10,000	10,000	10,000	10,000	6000	300	300
¾	9,000	4000	9,000	4000	9,000	4000	300	300

### Double Wound Coils—Series 2004–2304 Soft Seats (Buna N, Viton®, EPR, PTFE, and PCTFE)

ORIFICE SIZE	GASES		LIQUIDS TO 40 SUS		LIQUIDS OVER 40 SUS		STEAM	
	AC	DC	AC	DC	AC	DC	AC	DC
⅙	6000	4000	6000	3500	6000	2500	300	300
⅓	3500	2000	3000	1500	2000	1000	300	300
½	1000	800	600	600	500	500	300	300

Note: Buna N, Viton® and EPR seats are limited to 500 psig (34.5 barg).

## Dimensions and Shipping Weights

CATALOG NUM. PREFIX		PIPE SIZE	X	Y	NEMA 1 Z <sup>1</sup>	NEMA 7 Z <sup>2</sup>	SHIPPING WEIGHT (lbs)
SINGLE WOUND COIL	DOUBLE WOUND COIL						
2000	2004	⅝"	7⅞"	6"	2¾"	4 11/16"	7
2100	2104	¼"	7⅞"	6"	2¾"	4 11/16"	7
2200	2204	⅜"	7⅞"	6"	2¾"	4 11/16"	7
2300	2304	½"	7⅞"	6"	2¾"	4 11/16"	7

## Cv Flow Factors

ORIFICE SIZE	Cv
½	0.020
¾	0.056
⅙	0.093
⅓	0.22
½	0.44
¾	0.72

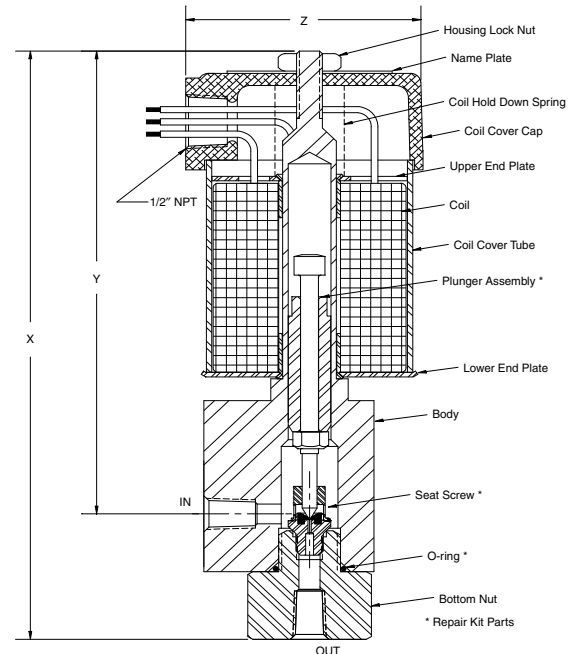

2004 Series ⅝" valve shown with NEMA 1 coil housing and a soft seat

# 2000 Series

## How to Order

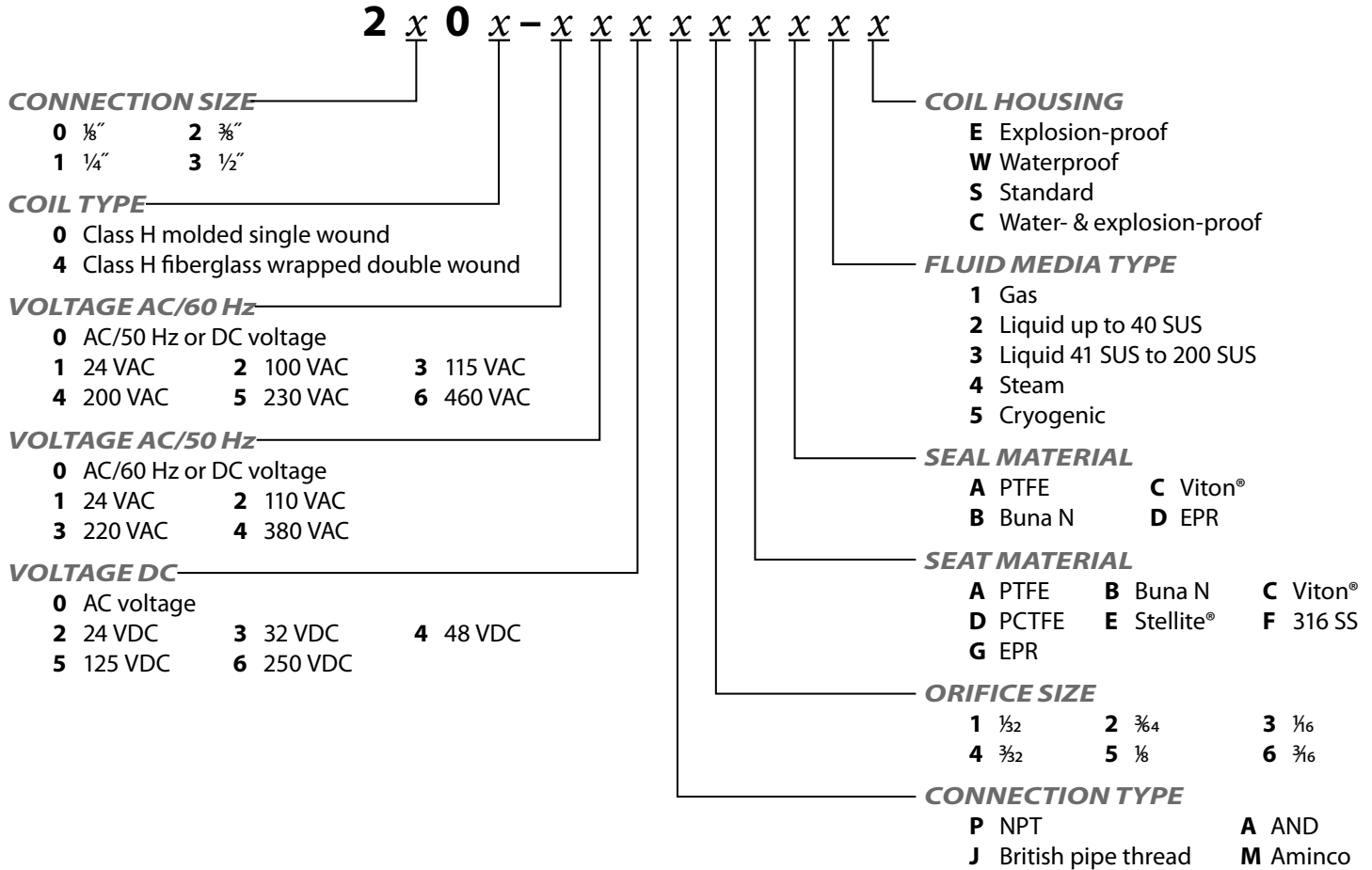

Viton® is a registered trademark of DuPont Dow Elastomers.  
Stellite® is a registered trademark of Deloro Stellite Company Inc.



# ATKOMATIC

## 3000 Series

Bronze, Direct Lift Medium Pressure Valve to 1500 psig (104 bar)  
Configurable for Variety of Fluid Applications



### Features

- |  |  |
|--|--|
| • Direct acting valve  | • Body seal materials of PTFE, Viton®, Buna N, or EPR  |
| • Pressure to 1500 psig (104 bar) depending on fluid and orifice size  | • Pipe sizes of 1/4, 3/8, 1/2, 3/4, and 1" NPT   |
| • Available in normally open and normally closed versions  | • British BSPT ports available   |
| • <b>Bronze valve material (naval M bronze) % plunger is electroless nickel plated 416 stainless</b>                       | • Flow orifice sizes of 1/16, 3/32, 1/8, & 3/16"   |
| • For use with any gas or liquid (max. viscosity of 200 SSU), including steam and cryogenic, that is not harmful to bronze | • Cv from 0.093 to 0.72  |
| • Fluid temperatures from -423° to +500° F (-253° C to +260° C)  | • Coil housings available in NEMA 1 (standard), NEMA 4 (waterproof), NEMA 7 (explosion-proof for hazardous locations), and combination NEMA 4 & 7      |
| • Optional seat materials of PTFE, PCTFE, Buna N, Viton®, EPR, or 316 stainless steel depending on fluid type and pressure | • Class B coils are available for media temperatures of 0° through 220° F  |
|  | • Class H coils are available: recommended for media temperatures of -423° through +500° F (-253° C to +260° C) (is standard on normally open version) |

### Circle Seal Controls

2301 Wardlow Circle • P.O. Box 3300 • Corona, CA 92880

Phone (951) 270-6200 Fax (951) 270-6201

www.circlesealcontrols.com • am\_sales@circlesealcontrols.com • ind\_sales@circlesealcontrols.com

atkomatic solenoid

# 3000 Series

## Operational Pressures (No minimum pressure differential)

### Normally Closed 3000–3400 & 3008–3408 Metal Seats

ORIFICE SIZE	GASES		LIQUIDS TO 40 SUS		LIQUIDS OVER 40 SUS		STEAM	
	AC	DC	AC	DC	AC	DC	AC	DC
1/6	1000*	1000*	1000*	1000	1000*	500	250	250
3/32	1000*	500	800	350	500	150	250	250
1/8	500	200	400	125	250	60	250	125
3/16	175	50	125	35	125	20	165	35

### Normally Closed 3000–3400 & 3008–3408 Soft Seats (Buna N, Viton®, EPR, PTFE, & PCTFE)

ORIFICE SIZE	GASES		LIQUIDS TO 40 SUS		LIQUIDS OVER 40 SUS		STEAM	
	AC	DC	AC	DC	AC	DC	AC	DC
1/6	1000*	1000*	1000*	765	1000*	500	250	250
3/32	1000*	425	675	300	425	170	250	250
1/8	425	170	350	100	200	50	250	100
3/16	150	40	100	30	100	17	140	30

### Normally Open 3001–3401 Metal Seats

ORIFICE SIZE	GASES		LIQUIDS TO 40 SUS		LIQUIDS OVER 40 SUS		STEAM	
	AC	DC	AC	DC	AC	DC	AC	DC
1/6	1000*	800	1000	350	700	300	250	250
3/32	500	250	300	150	275	90	250	250
1/8	225	100	200	50	125	35	200	150
3/16	65	25	40	15	25	10	50	25

### Normally Open 3001–3401 Soft Seats (Buna N, Viton®, EPR, PTFE, & PCTFE)

ORIFICE SIZE	GASES		LIQUIDS TO 40 SUS		LIQUIDS OVER 40 SUS		STEAM	
	AC	DC	AC	DC	AC	DC	AC	DC
1/6	1000*	680	1000	300	600	250	250	250
3/32	425	200	250	125	230	75	200	200
1/8	190	85	170	40	100	30	170	125
3/16	65	20	35	12	20	8	40	20

\* 1500 psi for 1/4, 3/8, and 1/2" sizes only

NOTE: Normally open 3001 Series valves are subject to the intermittent operation restrictions described on page 8.

Note: Buna N, Viton® and EPR seats are limited to 500 psi

### Normally Open 3007–3407 Soft Seats (Buna N, Viton®, EPR, PTFE, & PCTFE)

ORIFICE SIZE	GASES		LIQUIDS TO 40 SUS		LIQUIDS OVER 40 SUS		STEAM	
	AC	DC	AC	DC	AC	DC	AC	DC
1/6	1000	1000	1000	765	1000	500	250	250
3/32	1000	425	675	300	425	170	250	250
1/8	425	170	350	100	200	50	250	100
3/16	150	40	100	30	100	17	140	30

# 3000 Series

## Dimensions and Shipping Weights

### 3000 Series Normally Closed Bronze

CATALOG NUM. PREFIX		PIPE SIZE	X	Y	Z	SHIPPING WEIGHT (lbs)
CLASS B COIL	CLASS H COIL					
3000	3008	1/4"	7 7/16"	6 1/2"	2 1/16"	5
3100	3108	3/8"	7 7/16"	6 1/2"	2 1/16"	5
3200	3208	1/2"	7 7/16"	6 1/2"	3"	6
3300	3308	3/4"	7 1/16"	6 3/8"	3 3/4"	7
3400	3408	1"	7 1/16"	6 5/8"	3 3/4"	7

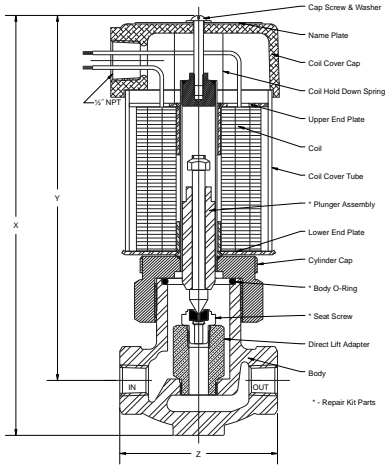

### Cv Flow Factors

ORIFICE SIZE	Cv
1/16	0.093
3/32	0.22
1/8	0.44
3/16	0.72

Normally closed 1/4" 3000 valve, shown with a NEMA 1 coil housing and a soft seat

### 3000 Series Normally Open Bronze

CATALOG NUM. PREFIX		PIPE SIZE	X	Y	Z	SHIPPING WEIGHT (lbs)
CLASS H COIL	CLASS H COIL					
3001/3007	3007	1/4"	9 3/32"	8 3/16"	2 1/16"	7
3101/3107	3107	3/8"	9 3/32"	8 3/16"	2 1/16"	7
3201/3207	3207	1/2"	9 3/16"	8 3/16"	3"	7
3301/3307	3307	3/4"	9 1/2"	8 1/4"	3 3/4"	8
3401/3407	3407	1"	9 1/2"	8 1/4"	3 3/4"	8

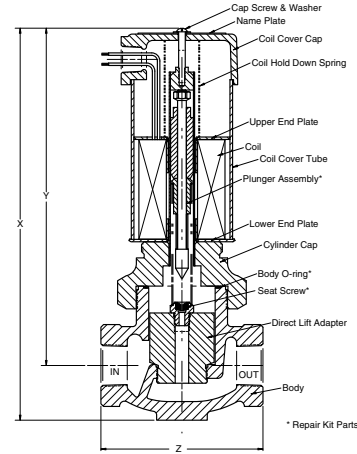

Normally open 1/4" 3001 valve, shown with a NEMA 1 coil housing and a soft seat

## How to Order

**3** x **0** x - x x x x x x x x x x

### PIPE THREAD SIZE

- 0** 1/4"      **3** 3/4"
- 1** 3/8"      **4** 1"
- 2** 1/2"

### PLUNGER/ORIFICE STYLE & COIL TYPE & NORMAL POSITION OF VALVE

- 0** Class B molded coil, normally closed valve
- 1** Class H molded coil, normally open valve
- 8** Class H molded coil, normally closed valve

### VOLTAGE AC/60 Hz

- 0** AC/50 Hz or DC voltage
- 1** 24 VAC    **2** 100 VAC    **3** 115 VAC
- 4** 200 VAC    **5** 230 VAC    **6** 460 VAC

### VOLTAGE AC/50 Hz

- 0** AC/60 Hz or DC voltage
- 1** 24 VAC    **2** 110 VAC
- 3** 220 VAC    **4** 380 VAC

### VOLTAGE DC

- 0** AC voltage
- 1** 12 VDC    **2** 24 VDC    **3** 32 VDC
- 4** 72 VDC    **5** 125 VDC    **6** 250 VDC

### CONNECTION TYPE

- P** NPT
- J** British pipe thread

### COIL HOUSING

- E** Explosion-proof
- W** Waterproof
- S** Standard
- C** Water- & explosion-proof

### FLUID MEDIA TYPE

- 1** Gas
- 2** Liquid up to 40 SUS
- 3** Liquid 40 SUS to 200 SUS
- 4** Steam
- 5** Cryogenic

### SEAL MATERIAL

- A** PTFE
- B** Buna N
- C** Viton®
- D** EPR

### SEAT MATERIAL

- A** PTFE
- B** Buna N
- C** Viton®
- D** EPR
- E** PCTFE
- F** Stainless

### ORIFICE SIZE

- 1** 1/16      **2** 3/32      **3** 1/8
- 4** 3/16

Viton® is a registered trademark of DuPont Dow Elastomers.

# ATKOMATIC

## 4000 & 5000 Series

Bronze, Pilot-piston, Pressure 5 to 500 psig (0.4 to 34.5 bar)  
Medium Pressure Valve Configurable for Variety of Fluid Applications



### Features

- Pressures to 500 psig (0.4 to 34.5 bar)
- Full ported valves
- Pilot operated: require a minimum pressure differential of 5 psig (0.4 bar)
- For use with any gas or liquid (max. viscosity of 200 SSU), including steam and cryogenics, that is not harmful to bronze
- Pipe sizes of 1/4" through 1 1/2" NPT for 4000 Series and 2" through 3" NPT in 5000 Series (British BSPT ports available)
- Cv from 1.4 to 71
- Available in normally open and normally closed versions
- Fluid temperatures from -423° F to +500° F (-253° C to +260° C)
- Optional seat materials of PTFE, PCTFE, Buna N, Viton®, EPR, or metal (316 stainless steel pilot and/or brass piston seat) depending on fluid type and pressure
- Body seal materials of PTFE, Viton®, Buna N, or EPR.
- Bronze valve material (naval M Bronze)
- Removable 316 stainless steel body inserts (stainless steel trim) 4000 Series only
- Coil housings available in NEMA 1 (standard), NEMA 4 (waterproof), NEMA 7 (explosion-proof for hazardous locations), and combination NEMA 4 & 7
- Manual opening and throttling devices are available as options
- Class B coils are available for media temperatures of 0° F (-18° C) through +220° F (104° C) (available on both normally closed and normally open valves)
- Class H coils are available: recommended for media temperatures of -423° F (-253° C) through +500° F(+260° C) (available on both normally closed and normally open valves)

### Circle Seal Controls

2301 Wardlow Circle • P.O. Box 3300 • Corona, CA 92880

Phone (951) 270-6200 Fax (951) 270-6201

www.circlesealcontrols.com • am\_sales@circlesealcontrols.com • ind\_sales@circlesealcontrols.com

atkomatic solenoid

# 4000 & 5000 Series

## Operational Pressures (5 psid minimum pressure differential)

GASES		LIQUIDS TO 40 SUS		LIQUIDS OVER 40 SUS		STEAM	
AC	DC	AC	DC	AC	DC	AC	DC
500	500	500	500	500	300	200	200

Note: Normally open valves are rated for intermittent duty only unless other operational parameters are at their nominal values.

## Dimensions, Shipping Weights, and Cv Flow Factors

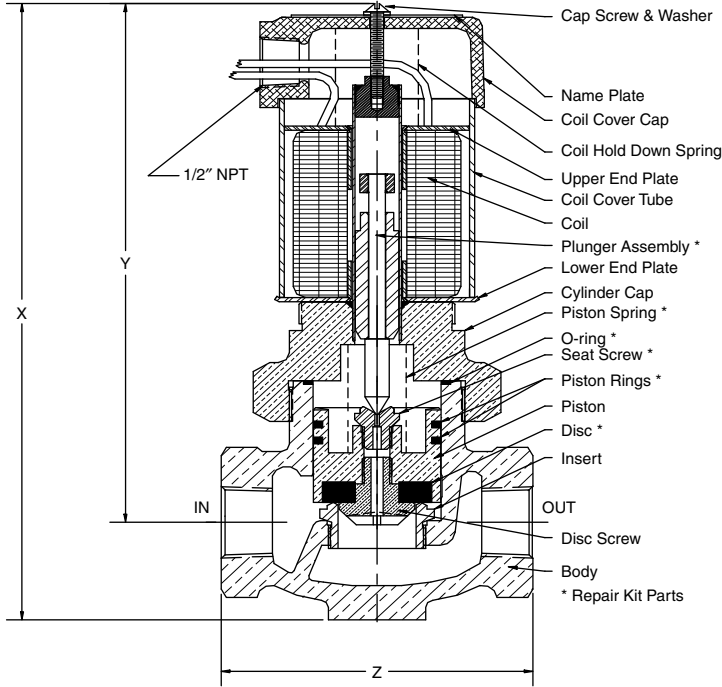

Normally closed 1" 4408 valve, shown with a NEMA 1 coil housing and a metal pilot seat

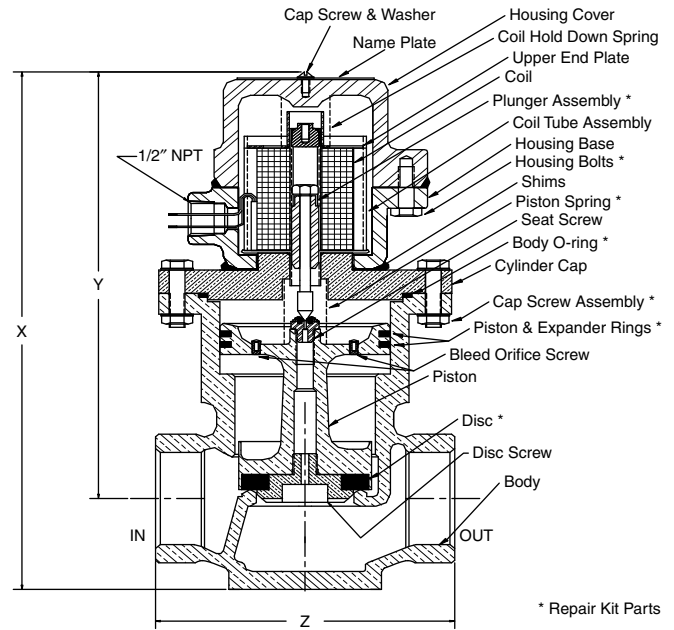

Normally closed 2" 5700 Valve, shown with a NEMA 7 explosion-proof coil housing and a soft pilot seat

## Normally Closed

CATALOG NUM. PREFIX		PIPE SIZE	MAIN SEAT ORIFICE	X	Y	Z	SHIPPING WEIGHT (lbs)	Cv
CLASS B COIL	CLASS H COIL							
4000	4008	1/4"	3/8"	7 1/8"	6 1/4"	2 1/16"	6	1.4
4100	4108	3/8"	3/8"	7 1/8"	6 1/4"	2 1/16"	6	2.7
4200	4208	1/2"	1/2"	7 1/8"	6 1/4"	3"	8	3.5
4300	4308	3/4"	1"	8 1/4"	7"	4"	9	8.4
4400	4408	1"	1"	8 1/4"	7"	4"	9	9.5
4500	4508	1 1/4"	1 1/2"	9 13/16"	8"	5 1/16"	15	19.5
4600	4608	1 1/2"	1 1/2"	9 13/16"	8"	5 1/16"	15	21.0
5700	5708	2"	2"	12 3/8"	9 3/4"	6 1/8"	35	43.0
5800	5808	2 1/2"	3"	14 3/8"	10 1/2"	8 1/2"	35	63.0
5900	5908	3"	3"	14 3/8"	10 1/2"	8 1/2"	76	71.0

# 4000 & 5000 Series

## Dimensions, Shipping Weights, and Cv Flow Factors

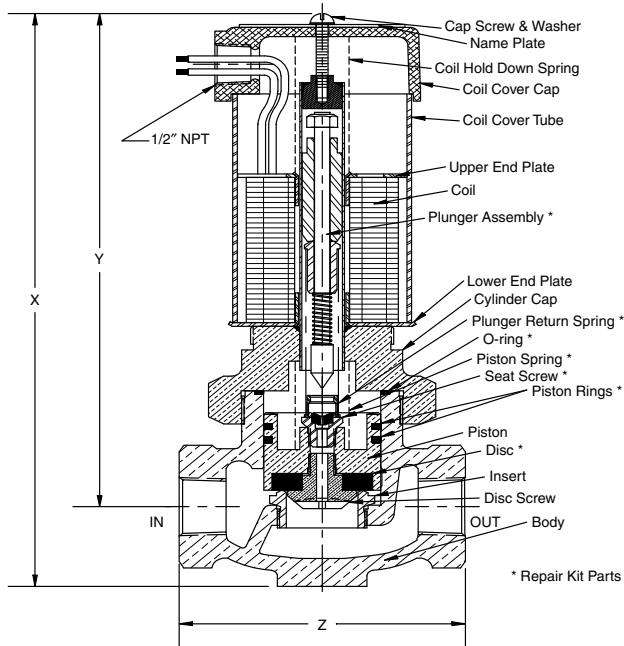

Normally open 1" 4407 valve, shown with a standard NEMA 1 coil housing and a soft pilot seat

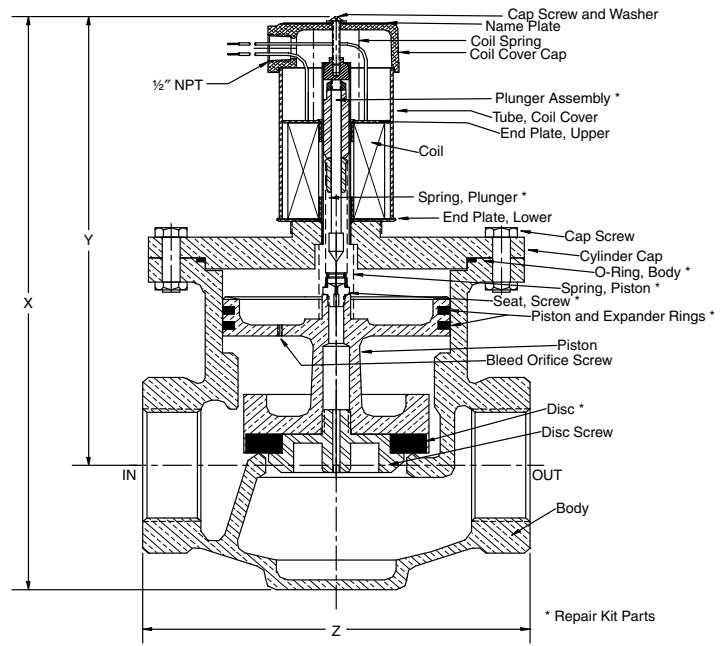

Normally open 2 1/2" 5801 valve, shown with a NEMA 1 coil housing and a metal pilot seat

### Normally Open

CATALOG NUM. PREFIX		PIPE SIZE	MAIN SEAT ORIFICE	X	Y	Z	SHIPPING WEIGHT (lbs)	Cv
CLASS B COIL	CLASS H COIL							
4001	4007	1/4"	3/8"	8 1/8"	7 1/4"	2 1/16"	6	1.4
4101	4107	3/8"	3/8"	8 1/8"	7 1/4"	2 1/16"	6	2.7
4201	4207	1/2"	1/2"	8 1/8"	7 1/4"	3"	8	3.5
4301	4307	3/4"	1"	9 7/16"	8 3/16"	4"	9	8.4
4401	4407	1"	1"	9 7/16"	8 3/16"	4"	9	9.5
4501	4507	1 1/4"	1 1/2"	11"	9 3/16"	5 1/16"	15	19.5
4601	4607	1 1/2"	1 1/2"	11"	9 3/16"	5 1/16"	15	21.0
5701	5707	2"	2"	13 3/4"	10 7/8"	6 1/8"	36	43.0
5801	5807	2 1/2"	3"	15 1/2"	11 3/8"	8 1/2"	75	63.0
5901	5907	3"	3"	15 1/2"	11 3/8"	8 1/2"	75	71.0

# 4000 & 5000 Series

## How to Order

x x 0 x - x x x x x x x x x x x

### VALVE SERIES

- 4** 4000 Series  
(are 1/4" through 1 1/2")
- 5** 5000 Series  
(are 2" through 3")

### CONNECTION SIZES

- 0** 1/4"
- 1** 3/8"      **4** 1"      **7** 2"
- 2** 1/2"      **5** 1 1/4"      **8** 2 1/2"
- 3** 3/4"      **6** 1 1/2"      **9** 3"

### COIL TYPE & NORMAL POSITION OF VALVE

- 0** Class B molded coil & normally closed valve
- 8** Class H molded coil & normally closed valve
- 1** Class B molded coil & normally open valve
- 7** Class H molded coil & normally open valve

### VOLTAGE AC/60 Hz

- 0** AC/50 Hz or DC voltage
- 1** 24 VAC    **3** 115 VAC    **5** 230 VAC
- 2** 100 VAC    **4** 200 VAC    **6** 460 VAC

### VOLTAGE AC/50 Hz

- 0** AC/60 Hz or DC voltage
- 1** 24 VAC      **3** 220 VAC
- 2** 110 VAC     **4** 380 VAC

### VOLTAGE DC

- 0** AC voltage
- 1** 12 VDC    **3** 32 VDC    **5** 125 VDC
- 2** 24 VDC    **4** 72 VDC    **6** 250 VDC

### CONNECTION TYPE

- P** NPT
- J** British pipe thread

### OPTIONS

- T** Manual throttling
- M** Manual opening
- P** Position indicator

### COIL HOUSING

- E** Explosion-proof
- S** Standard
- W** Waterproof
- C** Combined water- & explosion-proof

### FLUID MEDIA TYPE

- 1** Gas
- 2** Liquid up to 40 SUS
- 3** Liquid from 41 SUS to 150 SUS
- 4** Steam
- 5** Cryogenic

### SEAL MATERIAL

- A** PTFE      **B** Buna N
- C** Viton®    **D** EPR

### SEAT/PILOT MATERIAL

- A** TFE pilot & TFE disc
- B** Buna N pilot & Buna N disc
- C** Viton® pilot & Viton® disc
- D** EPR pilot & EPR disc
- E** PCTFE pilot & PCTFE disc
- F** Metal pilot & Metal disc
- G** Metal pilot & TFE disc
- H** Metal pilot & Buna disc
- I** Metal pilot & Viton® disc
- J** Metal pilot & EPR disc
- K** Metal pilot & PCTFE disc

### MAX. OPERATING PRESS (psig)

- A** 25      **F** 200
- B** 50      **G** 250
- C** 75      **H** 300
- D** 100    **I** 500
- E** 150

# ATKOMATIC

## 6000 Series

Bronze, Pilot-piston, Pressure 0 to 1500 psig (0.4 to 103.5 bar)  
Medium Pressure Valve Configurable for Variety of Fluid Applications



### Features

- Pressures to 1500 psig (103.5 bar)
- Pilot operated: require a minimum pressure differential of 5 psig (0.4 bar)
- Full ported valves
- Fluid temperatures from  $-423^{\circ}\text{F}$  to  $+500^{\circ}\text{F}$  ( $-253^{\circ}\text{C}$  to  $+260^{\circ}\text{C}$ )
- For use with any gas or liquid (max. viscosity of 200 SSU), including steam and cryogenic, that is not harmful to bronze
- Pipe sizes of  $\frac{1}{4}$ " through  $1\frac{1}{2}$ " (British BSPT ports available)
- Cv from 1.4 to 21
- Available in normally open and normally closed versions
- Optional pilot & piston seat seal materials of PTFE, PCTFE, Buna N, Viton<sup>®</sup>, EPR, or metal (316 stainless steel pilot & brass piston seat) depending on fluid type and pressure
- Body seal materials of PTFE, Viton<sup>®</sup>, Buna N, or EPR.
- Bronze valve material (naval M bronze)
- Removable 316 stainless steel body inserts (stainless steel trim)
- Coil housings available in NEMA 1 (standard), NEMA 4 (waterproof), NEMA 7 (explosion-proof for hazardous locations), and combination NEMA 4 & 7
- Manual opening and throttling devices are available as options
- Class B coils are available for media temperatures of  $0^{\circ}\text{F}$  ( $-18^{\circ}\text{C}$ ) through  $+220^{\circ}\text{F}$  ( $104^{\circ}\text{C}$ ) (available on both normally closed and normally open valves)
- Class H coils are available: recommended for media temperatures of  $-423^{\circ}\text{F}$  ( $-253^{\circ}\text{C}$ ) through  $+500^{\circ}\text{F}$  ( $+260^{\circ}\text{C}$ ) (available on both normally closed and normally open valves)
- Treated 416 stainless steel plunger material for increased corrosion resistance

### Circle Seal Controls

2301 Wardlow Circle • P.O. Box 3300 • Corona, CA 92880

Phone (951) 270-6200 Fax (951) 270-6201

www.circlesealcontrols.com • am\_sales@circlesealcontrols.com • ind\_sales@circlesealcontrols.com

atkomatic solenoid



# 6000 Series

## Operational Pressures (5 psid minimum pressure differential)

Normally closed 6000–6200 ¼" through ½"

GASES		LIQUIDS TO 40 SUS		LIQUIDS OVER 40 SUS		STEAM	
AC	DC	AC	DC	AC	DC	AC	DC
1500	1500	1500	1000	1,200	600	200	200

Normally closed 6300–6600 ¾" through 1½"

GASES		LIQUIDS TO 40 SUS		LIQUIDS OVER 40 SUS		STEAM	
AC	DC	AC	DC	AC	DC	AC	DC
1000	1000	1000	1000	1000	600	200	200

Normally open 6001–6201 ¼" through ½"

GASES		LIQUIDS TO 40 SUS		LIQUIDS OVER 40 SUS		STEAM	
AC	DC	AC	DC	AC	DC	AC	DC
1500	1000	1000	500	1000	350	200	200

Normally open 6301–6601 ¾" through 1½"

GASES		LIQUIDS TO 40 SUS		LIQUIDS OVER 40 SUS		STEAM	
AC	DC	AC	DC	AC	DC	AC	DC
1000	1000	1000	500	1000	350	200	200

**Note:** Normally open 6001 Series valves are rated for intermittent duty only, unless other operational parameters are at their nominal values.

**Note:** Buna N, Viton® and EPR seats are limited to 500 psi (34.5 bar)

## Dimensions, Shipping Weights, and Cv Flow Factors

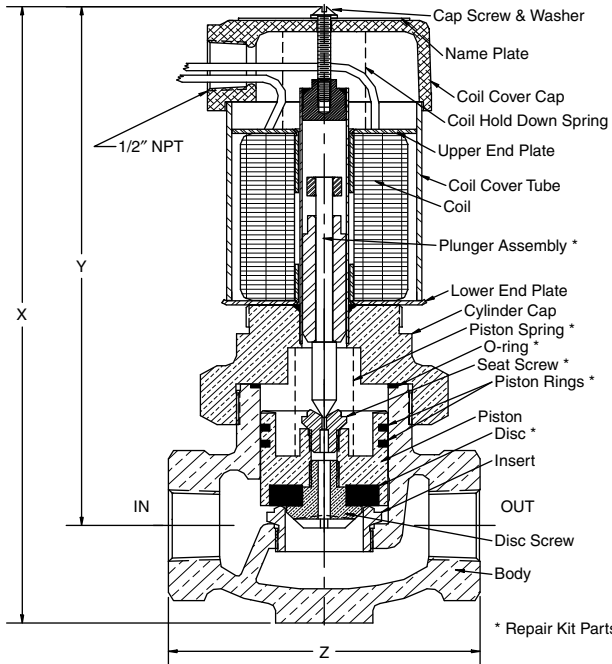

Normally closed 1" 6400 valve, shown with a NEMA 1 coil housing and a metal pilot seat

### Normally Closed

CATALOG NUM.	PIPE SIZE	MAIN SEAT ORIFICE	X	Y	Z	SHIPPING WEIGHT (lbs)	Cv
6000	¼"	⅜"	7⅞"	6¼"	2⅛"	6	1.4
6100	⅜"	⅜"	7⅞"	6¼"	2⅛"	6	2.7
6200	½"	½"	7⅞"	6¼"	3"	8	3.5
6300	¾"	1"	8¼"	7"	4"	9	8.4
6400	1"	1"	8¼"	7"	4"	9	9.5
6500	1¼"	1½"	9⅜"	8"	5⅛"	15	19.5
6600	1½"	1½"	9⅜"	8"	5⅛"	15	21.0

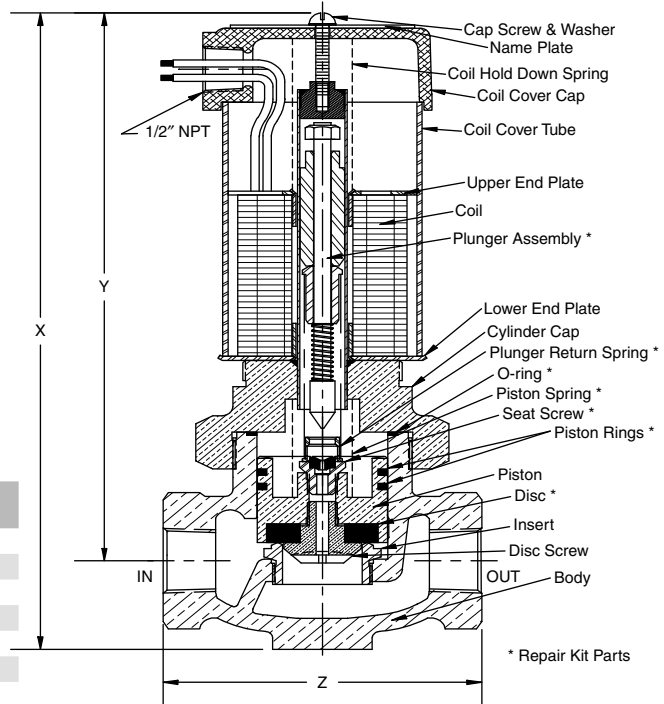

Normally open 1" 6401 valve, shown with a NEMA 1 coil housing and a soft pilot seat

### Normally Open

CATALOG NUM.	PIPE SIZE	MAIN SEAT ORIFICE	X	Y	Z	SHIPPING WEIGHT (lbs)	Cv
6001	¼"	⅜"	8⅞"	7¼"	2⅛"	6	1.4
6101	⅜"	⅜"	8⅞"	7¼"	2⅛"	6	2.7
6201	½"	½"	8⅞"	7¼"	3"	8	3.5
6301	¾"	1"	9⅞"	8⅜"	4"	9	8.4
6401	1"	1"	9⅞"	8⅜"	4"	9	9.5
6501	1¼"	1½"	11"	9⅜"	5⅛"	15	19.5
6601	1½"	1½"	11"	9⅜"	5⅛"	15	21.0

# 6000 Series

## How to Order

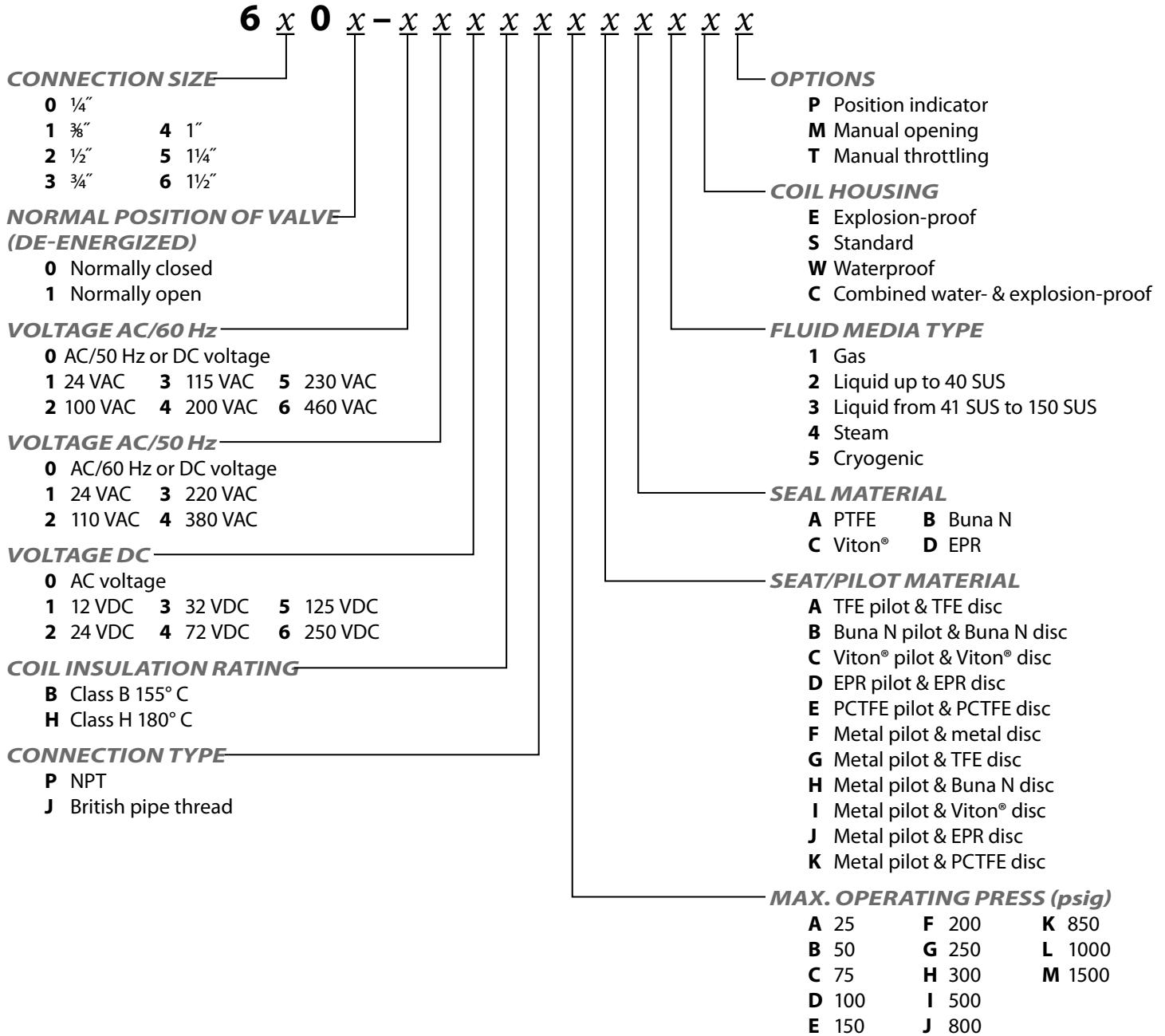

Viton® is a registered trademark of DuPont Dow Elastomers.

# ATKOMATIC

## 7000 Series

Stainless Steel, Pilot-piston, Pressure 5 to 6000 psig (0.4 to 414 bar)  
High Pressure Valve Configurable for Variety of Fluid Applications



### Features

- Pressure to 6000 psig (414 bar)
- Pilot operated: require a minimum pressure differential of 5 psig (0.4 bar)
- Barstock body configuration
- Fluid temperatures of  $-423^{\circ}\text{F}$  ( $-253^{\circ}\text{C}$ ) through  $+500^{\circ}\text{F}$  ( $+260^{\circ}\text{C}$ ) (Kel-F<sup>®</sup> piston recommended for  $-400^{\circ}\text{F}$  ( $-240^{\circ}\text{C}$ ) through  $+400^{\circ}\text{F}$  ( $+204^{\circ}\text{C}$ ))
- All 316 stainless steel construction on pressure containing parts; plunger material is 416 stainless that is treated for increased corrosion resistance
- Will handle fluids with viscosity up to 200 SUS
- Suitable for use with wide variety of fluid including: air, gasses, liquids, hydraulic fluids, steam, cryogenic fluids, and corrosive fluids
- Piston material (same as seat material) of PCTFE or 17-4 stainless steel
- Body seal materials of PTFE, Viton<sup>®</sup>, Buna N, or EPR
- Pipe ports of  $\frac{1}{4}$ ",  $\frac{3}{8}$ ", or  $\frac{1}{2}$ " NPT (British BSPT ports available)
- Flow orifice of  $\frac{5}{16}$ "
- Cv from 1.0 to 2.0
- Uses a class H fiberglass wrapped, double wound coil (requires use with a relay to drop put primary coil winding after valve actuation)
- Coil housings available in NEMA 1 (standard), NEMA 4 (waterproof), NEMA 7 (explosion-proof for hazardous locations), and combination NEMA 4 & 7

### Operational Pressures (5 psi minimum pressure differential)

GASES		LIQUIDS TO 40 SUS		LIQUIDS OVER 40 SUS		STEAM	
AC	DC	AC	DC	AC	DC	AC	DC
6000	4000	6000	3500	6000	2500	300	300
414 bar	276 bar	414 bar	242 bar	414 bar	173 bar	21 bar	21 bar

### Circle Seal Controls

2301 Wardlow Circle • P.O. Box 3300 • Corona, CA 92880

Phone (951) 270-6200 Fax (951) 270-6201

www.circlesealcontrols.com • am\_sales@circlesealcontrols.com • ind\_sales@circlesealcontrols.com

atkomatic solenoid

# 7000 Series

## Dimensions, Shipping Weights, and Cv Flow Factors

CATALOG NUM. PREFIX	PIPE SIZE	MAIN SEAT ORIFICE	X	Y	Z	SHIPPING WEIGHT (lbs)	Cv
7004	1/4"	5/16"	7 5/16"	6"	2 3/4"	7	1.0
7104	3/8"	5/16"	7 5/16"	6"	2 3/4"	7	2.0
7204	1/2"	5/16"	7 5/16"	6"	2 3/4"	7	2.0

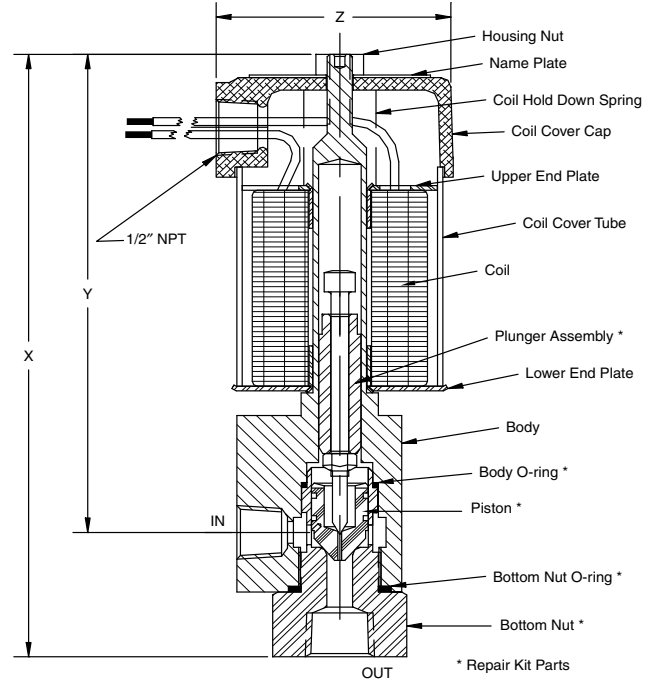

7104 3/8" Valve, shown with a NEMA 1 coil housing

## How to Order

**7 x 0 4 - x x x x x x x x x**

**CONNECTION SIZES**

- 0 1/4"
- 1 3/8"
- 2 1/2"

**VOLTAGE AC/60 Hz**

- 0 AC/60 Hz or DC voltage
- 1 100 VAC    3 200 VAC    5 460 VAC
- 2 115 VAC    4 230 VAC    6 550 VAC

**VOLTAGE AC/50 Hz**

- 0 AC/60 Hz or DC voltage
- 1 110 VAC    2 220 VAC

**VOLTAGE DC**

- 0 AC voltage
- 1 24 & 32 VDC    3 125 VDC
- 2 48 VDC        4 250 VDC

**CONNECTION TYPE**

- P NPT
- J British pipe thread

**COIL HOUSING**

- E Explosion-proof
- S Standard
- W Waterproof
- C Combined water- & explosion-proof

**FLUID MEDIA TYPE**

- 1 Gas
- 2 Liquid up to 40 SUS
- 3 Liquid from 41 SUS to 150 SUS
- 4 Steam
- 5 Cryogenic

**SEAL MATERIAL**

- A PTFE        B Buna N
- C Viton®      D EPR

**SEAT/PISTON MATERIAL**

- 1 PCTFE
- 2 Stainless steel
- 3 Stainless steel piston with Stellite® stem

**MAX. OPERATING PRESS (psig)**

A 300	E 1000	I 3500
B 500	F 1500	J 4000
C 700	G 2000	K 5000
D 800	H 2500	L 6000

Viton® is a registered trademark of DuPont Dow Elastomers.  
Stellite® is a registered trademark of Deloro Stellite Company Inc.

# ATKOMATIC

## 8000 Series

Stainless Steel, Pilot-piston, Pressure 5 to 4000 psig (0.4 to 276 bar)  
High Pressure Valve Configurable for Variety of Fluid Applications



### Features

- Pressure to 4000 psig depending on fluid and coil type (276 bar)
- Pilot operated: require a minimum pressure differential of 5 psig (0.4 bar)
- Full ported valves
- Available in normally open and normally closed versions
- Fluid temperatures of  $-423^{\circ}\text{F}$  ( $-253^{\circ}\text{C}$ ) through  $+500^{\circ}\text{F}$  ( $+260^{\circ}\text{C}$ )
- Stainless steel construction on all wetted parts—316 for machined parts and CF8M for cast parts. Plunger material is 416 stainless that is treated for increased corrosion resistance
- Will handle fluids with viscosity up to 200 SUS
- Suitable for use with wide variety of fluid including: air, gasses, liquids, hydraulic fluids, steam, cryogenic fluids, and corrosive fluids
- Removable 316 stainless steel body inserts (stainless steel trim)
- Optional pilot and piston seat materials of PTFE, PCTFE, Buna N, Viton<sup>®</sup>, EPR, or 316 stainless steel depending on fluid type and pressure
- Body seal materials of PTFE, Viton<sup>®</sup>, Buna N, or EPR
- Pipe ports of  $\frac{1}{4}$ " through 2" NPT ( $1\frac{1}{2}$ " max. in 4000 psig (276 bar) version); British BSPT ports available
- Cv from 1.1 through 45
- Class H coils standard
- Can use a class H double wound coil (requires use with a relay to drop put primary coil winding after valve actuation) depending on pressure (for operation up to 4000 psi (276 bar))
- Coil housings available in NEMA 1 (standard), NEMA 4 (waterproof), NEMA 7 (explosion-proof for hazardous locations), and combination NEMA 4 & 7
- Manual opening device is available as an option

### Circle Seal Controls

2301 Wardlow Circle • P.O. Box 3300 • Corona, CA 92880

Phone (951) 270-6200 Fax (951) 270-6201

www.circlesealcontrols.com • am\_sales@circlesealcontrols.com • ind\_sales@circlesealcontrols.com

atkomatic solenoid

# 8000 Series

## Operational Pressures (5 psid minimum pressure differential)

Single wound coils normally closed 1/4" through 2" 8000-8710

GASES		LIQUIDS TO 40 SUS		LIQUIDS OVER 40 SUS		STEAM	
AC	DC	AC	DC	AC	DC	AC	DC
1500 / 104 bar	1500 / 104 bar	1500 / 104 bar	1000 / 69 bar	1500 / 104 bar	500 / 34.5 bar	300 / 21 bar	250 / 17.3 bar

Single wound coils normally open 1/4" through 2" 8001-8711

GASES		LIQUIDS TO 40 SUS		LIQUIDS OVER 40 SUS		STEAM	
AC	DC	AC	DC	AC	DC	AC	DC
1500 / 104 bar	800 / 55.2 bar	1000 / 69 bar	350 / 24.2 bar	700 / 48.3 bar	300 / 21 bar	250 / 17.3 bar	250 / 17.3 bar

Double wound coils normally closed only 1/4" through 1 1/2" 8004-8604

GASES		LIQUIDS TO 40 SUS		LIQUIDS OVER 40 SUS		STEAM	
AC	DC	AC	DC	AC	DC	AC	DC
4000 / 276 bar	3000 / 207 bar	4000 / 276 bar	2500 / 173 bar	4000 / 276 bar	2000 / 138 bar	300 / 21 bar	300 / 21 bar

**Note:** Normally open valves are rated for intermittent duty only on 8000 Series.

**Note:** Buna N, Viton® and EPR seats are limited to 500 psig (34.5 barg).

## Dimensions, Shipping Weights, and Cv Flow Factors

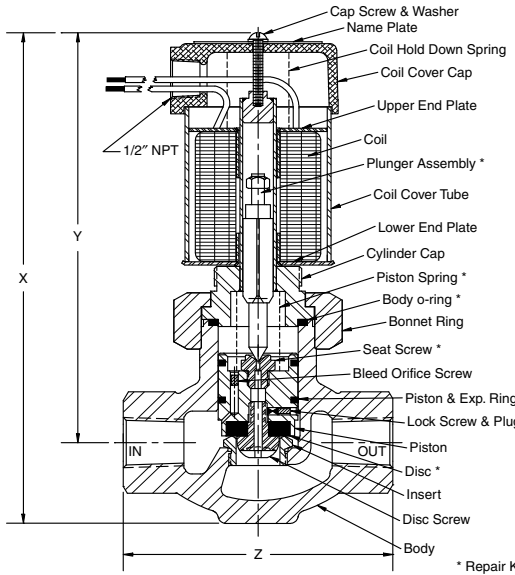

Normally closed 1/2" 8200 valve, shown with a NEMA 1 coil housing and a metal pilot seat

### 8000 Series Normally Closed, Single and Double Wound Coils

CATALOG NUM. PREFIX		PIPE SIZE	MAIN SEAT ORIFICE	X	Y	Z	SHIPPING WEIGHT (lbs)	Cv
SINGLE WOUND COIL	DOUBLE WOUND COIL							
8000	8004	1/4"	3/8"	7"	6 1/2"	3"	6	1.1
8100	8104	3/8"	3/8"	7"	6 1/2"	3"	6	2.5
8200	8204	1/2"	3/4"	8 1/2"	7 3/8"	4 5/8"	9	5.1
8300	8304	3/4"	3/4"	8 1/2"	7 3/8"	4 5/8"	9	7.5
8400	8404	1"	1"	9 3/16"	7 1/16"	5 1/4"	14	12.5
8510	8504	1 1/4"	1 1/2"	9 1/2"	7 5/8"	5 7/8"	20	19.5
8610	8604	1 1/2"	1 1/2"	9 1/2"	7 5/8"	5 7/8"	20	21.0
8710	—	2"	2"	11 7/8"	9 1/2"	7"	28	45.0

Note: 2" size available in single wound, 1500 psi max. only (104 bar).

### 8000 Series Normally Open Single Wound Coils Only

CATALOG NUM. PREFIX	PIPE SIZE	MAIN SEAT ORIFICE	X	Y	Z	SHIPPING WEIGHT (lbs)	Cv
8001	1/4"	3/8"	8 1/8"	7 5/16"	3"	6	1.1
8101	3/8"	3/8"	8 1/8"	7 5/16"	3"	6	2.5
8201	1/2"	3/4"	9 5/8"	8 1/2"	4 5/8"	9	5.1
8301	3/4"	3/4"	9 5/8"	8 1/2"	4 5/8"	9	7.5
8401	1"	1"	10 3/16"	8 13/16"	5 1/4"	14	12.5
8511	1 1/4"	1 1/2"	10 11/16"	8 13/16"	5 7/8"	20	19.5
8611	1 1/2"	1 1/2"	10 11/16"	8 13/16"	5 7/8"	20	21.0
8711	2"	2"	13"	10 5/8"	7"	28	45.0

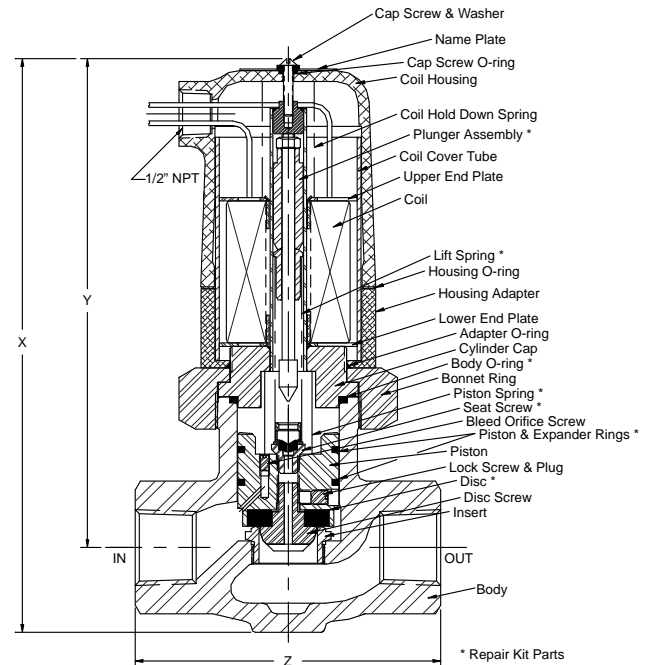

Normally open 1" 8401 valve, shown with a NEMA 4 waterproof coil housing and a soft pilot seat

# 8000 Series

## How to Order

**8** X X X - X X X X X X X X X X X

### CONNECTION SIZES

- |        |          |          |
|--------|----------|----------|
| 0 1/4" | 4 1"     | 7 2"     |
| 1 3/8" | 5 1 1/4" | 8 2 1/2" |
| 2 1/2" | 6 1 1/2" | 9 3"     |
| 3 3/4" |          |          |

### PRODUCT PREFIX

- 0 1/4", 3/8", 1/2", 3/4" and 1" single wound coils and double wound coils.  
 1 1 1/4", 1 1/2", and 2" single wound coils.  
 This field conveys no meaning and is used only to match historic catalog numbers

### NORMAL POSITION OF VALVE

#### COIL TYPE (DE-ENERGIZED)

- 0 Normally closed valve & single wound coil  
 1 Normally open valve & single wound coil  
 4 Normally closed valve & double wound coil

### VOLTAGE AC/60 Hz

- 0 AC/50 Hz or DC voltage  
 1 24 VAC    3 115 VAC    5 230 VAC  
 2 100 VAC    4 200 VAC    6 460 VAC

### VOLTAGE AC/50 Hz

- 0 AC/60 Hz or DC voltage  
 1 24 VAC    3 220 VAC  
 2 110 VAC    4 380 VAC

### VOLTAGE DC

- 1 12 VDC    3 32 VDC    5 125 VDC  
 2 24 VDC    4 72 VDC    6 250 VDC

### CONNECTION TYPE

- P NPT  
 J British pipe thread

### OPTIONS

- P Position indicator  
 M Manual opening

### COIL HOUSING

- E Explosion-proof  
 S Standard  
 W Waterproof  
 C Combined water- & explosion-proof

### FLUID MEDIA TYPE

- 1 Gas  
 2 Liquid up to 40 SUS  
 3 Liquid from 41 SUS to 150 SUS  
 4 Steam  
 5 Cryogenic

### SEAL MATERIAL

- A PTFE    B Buna N  
 C Viton®    D EPR

### SEAT/PILOT MATERIAL

- A TFE pilot & TFE disc  
 B Buna N pilot & Buna N disc  
 C Viton® pilot & Viton® disc  
 D EPR pilot & EPR disc  
 E PCTFE pilot & PCTFE disc  
 F Metal pilot & metal disc  
 G Metal pilot & TFE disc  
 H Metal pilot & Buna N disc  
 I Metal pilot & Viton® disc  
 J Metal pilot & EPR disc  
 K Metal pilot & PCTFE disc

### MAX. OPERATING PRESS (psig)

- |       |       |        |
|-------|-------|--------|
| A 50  | F 300 | K 1000 |
| B 75  | G 400 | L 1500 |
| C 100 | H 500 | M 2000 |
| D 150 | I 600 | N 2500 |
| E 200 | J 750 | O 3000 |
|       |       | P 4000 |

# ATKOMATIC

## 12000 Series

Bronze, Pilot-piston, Pressure 5 to 3000 psig (0.4 to 207 bar)  
High Pressure Valve Configurable for Variety of Fluid Applications

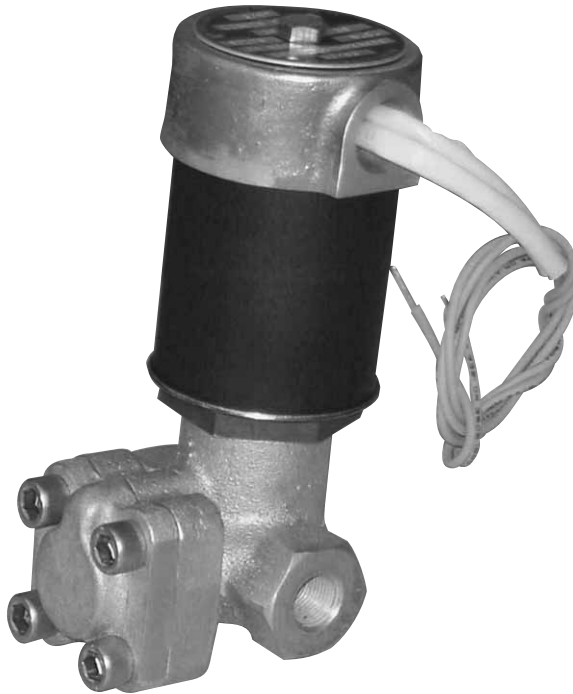

atkomatic solenoid

### Features

- Pressures to 3000 psig (207 bar)
- Fluid temperatures from  $-423^{\circ}\text{F}$  to  $+400^{\circ}\text{F}$  ( $-54^{\circ}\text{C}$  to  $+204^{\circ}\text{C}$ )
- For use with any gas or liquid (max. viscosity of 150 SSU) including steam, that is not harmful to bronze
- Pipe sizes of  $\frac{3}{8}$ " through 1" (British BSPT ports available)
- Full ported valve, Cv from 2.8 to 8.9
- Pilot operated: require a minimum pressure differential of 5 psig
- Optional pilot seat materials of PTFE, PCTFE, or 440 stainless steel
- Optional piston seat materials of PTFE, PCTFE, Buna N, Viton®, or EPR depending on fluid type and pressure
- Body seal materials of Viton®, Buna N, EPR, or Kalrez®
- Bronze valve material (naval M bronze)
- Removable 316 stainless steel body inserts (stainless steel trim)
- Coil housings available in NEMA 1 (standard), NEMA 4 (waterproof), NEMA 7 (explosion-proof for hazardous locations), and combination NEMA 4 & 7
- Manual opening device is available as an option
- Class B coils are available for media temperatures of  $0^{\circ}\text{F}$  through  $+220^{\circ}\text{F}$
- Class H coils are available: recommended for media temperatures of  $-423^{\circ}\text{F}$  through  $+400^{\circ}\text{F}$  ( $-54^{\circ}\text{C}$  to  $+204^{\circ}\text{C}$ )
- Can be mounted in any orientation
- Compact size and relatively low current draw with AC coils
- Treated 416 stainless steel plunger material for increased corrosion resistance

### Operational Pressures (5 psi minimum pressure differential)

GASES		LIQUIDS TO 40 SUS		LIQUIDS OVER 40 SUS		STEAM	
AC	DC	AC	DC	AC	DC	AC	DC
3000 / 207 bar	3000 / 207 bar	3000 / 207 bar	3000 / 207 bar	3000 / 207 bar	3000 / 207 bar	3000 / 207 bar	3000 / 207 bar

Note: Buna N, Viton® and EPR seats are limited to 500 psig (34.5 barg).

### Circle Seal Controls

2301 Wardlow Circle • P.O. Box 3300 • Corona, CA 92880

Phone (951) 270-6200 Fax (951) 270-6201

www.circlesealcontrols.com • am\_sales@circlesealcontrols.com • ind\_sales@circlesealcontrols.com



# 12000 Series

## Dimensions, Shipping Weights, and Cv Flow Factors

### 12000 Series AC

CATALOG NUM. PREFIX	PIPE SIZE	MAIN SEAT ORIFICE	X	Y	Z	SHIPPING WEIGHT (lbs)	Cv
12410	3/8"	1/2"	3 3/4"	4 3/4"	3 1/4"	6	2.8
12420	1/2"	1/2"	3 3/4"	4 3/4"	3 1/4"	6	4.2
12430	3/4"	1"	4 7/8"	6"	4 3/4"	11	8.5
12440	1"	1"	4 7/8"	6"	4 3/4"	11	8.9

### 12000 Series DC

CATALOG NUM. PREFIX	PIPE SIZE	MAIN SEAT ORIFICE	X	Y	Z	SHIPPING WEIGHT (lbs)	Cv
12410	3/8"	1/2"	7"	6"	3 1/4"	8	2.8
12420	1/2"	1/2"	7"	6"	3 1/4"	8	4.2
12430	3/4"	1"	8 1/4"	6 3/8"	4 3/4"	13	8.5
12440	1"	1"	8 1/4"	6 3/8"	4 3/4"	13	8.9

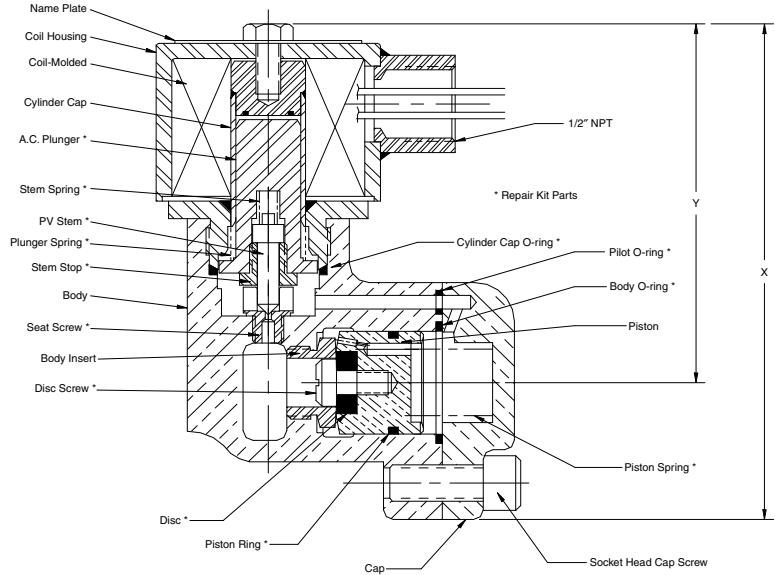

12410 3/8" Valve, shown with a NEMA 7 explosion-proof coil housing & AC coil

**124** x **0** - x x x x x x x x x x x x

#### CONNECTION SIZES

- 1 3/8"      3 3/4"
- 2 1/2"      4 1"

#### VOLTAGE AC/60 Hz

- 0 AC/50Hz or DC voltage
- 1 100 VAC    3 200 VAC    5 460 VAC
- 2 115 VAC    4 230 VAC

#### VOLTAGE AC/50 Hz

- 0 AC/60 Hz or DC voltage
- 1 110 VAC    2 220 VAC

#### VOLTAGE DC

- 0 AC voltage
- 1 12 VDC    2 24 VDC    3 125 VDC

#### COIL INSULATION RATING

- B Class B 155° C
- H Class H 180° C

#### CONNECTION TYPE

- P NPT
- J British pipe thread

#### MAX. OPERATING PRESSURE (psig)

- A 200      E 1,300      I 2,100
- B 500      F 1,400      J 2500
- C 850      G 1,900      K 3000
- D 1000    H 2000

#### OPTIONS

- M Manual opening device

#### COIL HOUSING

- E Explosion-proof
- S Standard
- W Waterproof
- C Combined water- & explosion-proof

#### FLUID MEDIA TYPE

- 1 Gas
- 2 Liquid up to 40 SUS
- 3 Liquid from 41 SUS to 150 SUS
- 4 Steam

#### SEAL MATERIAL

- B Buna N    C Viton®
- D EPR      K Kalrez®

#### SEAT/PILOT MATERIAL

- B TFE pilot & Buna N disc
- C TFE pilot & Viton® disc
- D TFE pilot & EPR disc
- E PCTFE pilot & PCTFE disc
- F PCTFE pilot & TFE disc
- G Metal pilot & TFE disc
- H Metal pilot & Buna N disc
- I Metal pilot & EPR disc
- J Metal pilot & PCTFE disc

# ATKOMATIC

## 13000 Series

Stainless Steel, 3-Way, Direct Lift, Pressure 0 to 2500 psig (173 bar)  
High Pressure Valve Configurable for Variety of Fluid Applications



atkomatic solenoid

### Features

- 3-Way valve
- Direct acting valve
- Barstock construction
- Can be installed as normally closed, normally open, or as a directional valve
- Can be mounted in any orientation (except normally open version)
- Pressure to 2500 psig (173 bar) depending on valve type, fluid and orifice size
- Media temperatures from  $-423^{\circ}\text{F}$  to  $+350^{\circ}\text{F}$  ( $-253^{\circ}\text{C}$  to  $177^{\circ}\text{C}$ )
- Stellite® seats (cobalt alloy for hardness and corrosion resistance)
- Ports sizes of  $\frac{1}{4}$ ",  $\frac{3}{8}$ ", and  $\frac{1}{2}$ " NPT (British BSBT ports available)
- Cv from 0.056 through 0.40
- Stainless steel construction on all wetted parts: 316 for pressure containing parts and plunger material is 416 stainless that is treated for increased corrosion resistance
- Will handle fluids with viscosity up to 150 SUS
- Class H coils standard
- Suitable for use with wide variety of fluid including: air, gasses, liquids, hydraulic fluids, steam, cryogenic fluids, and corrosive fluids
- Explosion-proof NEMA 7 coil housing is standard; can also be furnished with a combination water- and explosion-proof NEMA 4 & 7 coil housing

### Circle Seal Controls

2301 Wardlow Circle • P.O. Box 3300 • Corona, CA 92880

Phone (951) 270-6200 Fax (951) 270-6201

www.circlesealcontrols.com • am\_sales@circlesealcontrols.com • ind\_sales@circlesealcontrols.com

# 13000 Series

## Operational Pressures (No minimum pressure differential)

Normally Open 13110–13130 ¼"–½"

ORIFICE SIZE	GASES		LIQUIDS TO 40 SUS		LIQUIDS OVER 40 SUS		STEAM	
	AC	DC	AC	DC	AC	DC	AC	DC
¾"	2500	2500	2500	2500	2000	2000	300	300
½"	2,300	2,300	2,300	2,300	1,400	1,400	300	300
¾"	1,200	1,200	1,200	1,200	700	700	300	300
¼"	600	600	600	600	300	300	300	300

Directional 13310–13330 ¼"–½"

ORIFICE SIZE	GASES		LIQUIDS TO 40 SUS		LIQUIDS OVER 40 SUS		STEAM	
	AC	DC	AC	DC	AC	DC	AC	DC
¾"	2500	2500	2500	2500	2000	2000	300	300
½"	2500	2500	2,300	2,300	1,400	1,400	300	300
¾"	1,200	1,200	1,200	1,200	700	700	300	300
¼"	600	600	600	600	300	300	300	300

Normally Closed 13210–13230 ¼"–½"

ORIFICE SIZE	GASES		LIQUIDS TO 40 SUS		LIQUIDS OVER 40 SUS		STEAM	
	AC	DC	AC	DC	AC	DC	AC	DC
¾"	1,300	1,300	1,300	1,300	1,200	1,200	300	300
½"	1,200	1,200	1,200	1,200	1,100	1,100	300	300
¾"	600	600	600	600	500	500	300	300
¼"	300	300	300	300	250	250	300	300

Note: Normally open 13000 Series valves are NOT subject to intermittent operation restrictions

## Dimensions (inches), Shipping Weights and Cv Flow Factors

### Dimensions and Shipping Weights

CATALOG NUM. PREFIX							
NORMALLY OPEN (INLET B)	NORMALLY OPEN (INLET C)	DIRECTIONAL (INLET A)	PIPE SIZE	X	Y	Z	SHIPPING WEIGHT (lbs)
13110	13210	13310	¼"	7¼"	5½"	4¼"	10
13120	13220	13320	¾"	7¼"	5½"	4¼"	10
13130	13230	13330	½"	7¼"	5½"	4¼"	10

### Cv Flow Factors

ORIFICE SIZE	Cv
¾"	0.056
½"	0.093
¾"	0.22
¼"	0.44

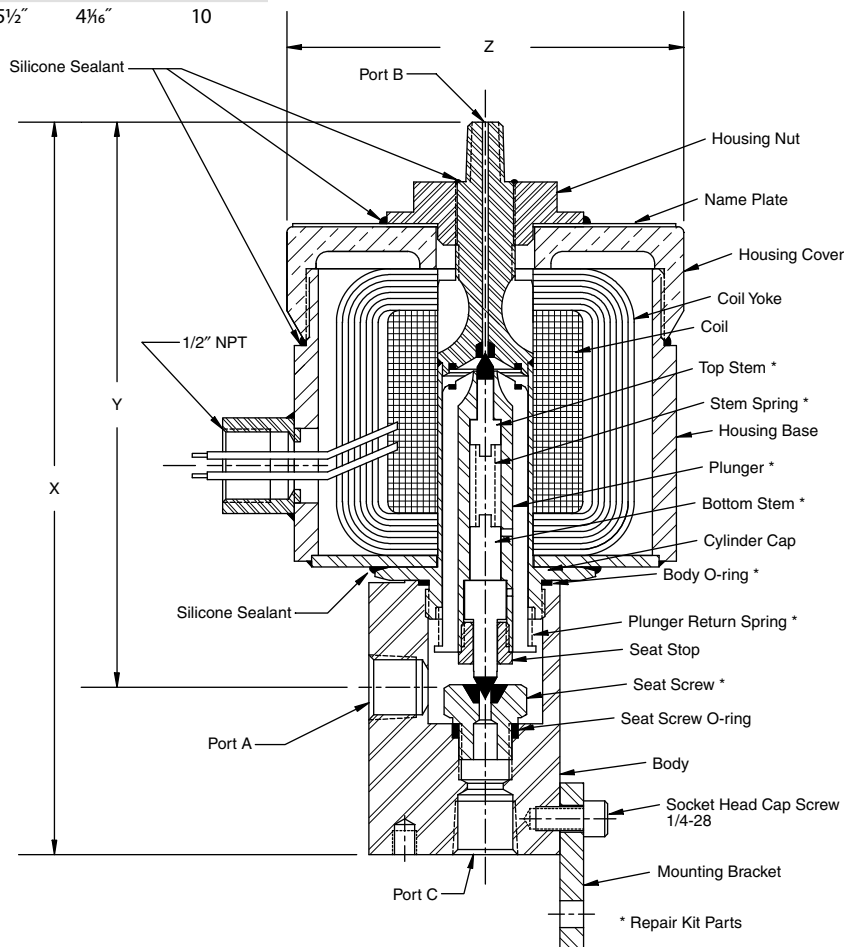

13230 ½" 3-Way valve, shown with a combination explosion-proof NEMA 7 and waterproof NEMA 4 coil housing

# 13000 Series

The 13000 Series valve can be built as either a normally open, a normally closed, or a directional valve. For each types of function different ports are used as the inlet and outlet ports. The valve itself is exactly the same. These different types of valve functions are illustrated by the following schematics:

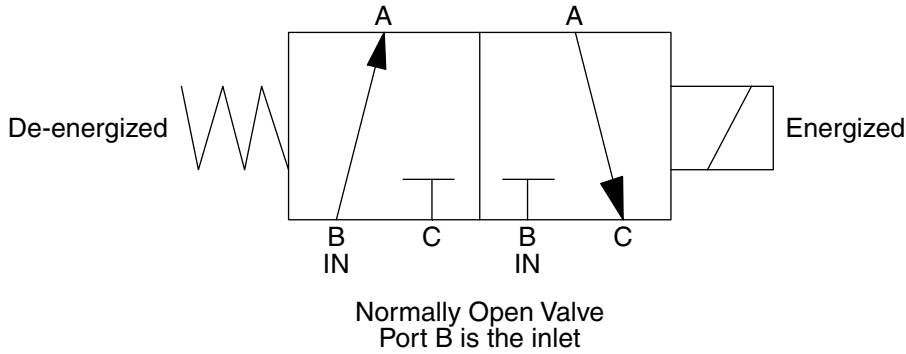

## How to Order

**13** x x **0** - x x x x x x x x

<p><b>VALVE TYPE</b></p> <ul style="list-style-type: none"> <li>1 3-Way valve, normally open</li> <li>2 3-Way valve, normally closed</li> <li>3 3-Way valve, distributor (FLIP-FLOP)</li> </ul> <p><b>PORT CONNECTION SIZE</b></p> <ul style="list-style-type: none"> <li>1 1/4"</li> <li>2 3/8"</li> <li>3 1/2"</li> </ul> <p><b>VOLTAGE AC/60 Hz</b></p> <ul style="list-style-type: none"> <li>0 AC/50 Hz or DC voltage</li> <li>1 100 VAC      4 230 VAC</li> <li>2 115 VAC      5 460 VAC</li> <li>3 200 VAC</li> </ul> <p><b>VOLTAGE AC/50 Hz</b></p> <ul style="list-style-type: none"> <li>0 AC/60 Hz or DC voltage</li> <li>1 110 VAC</li> <li>2 220 VAC</li> </ul> <p><b>VOLTAGE DC</b></p> <ul style="list-style-type: none"> <li>0 AC voltage</li> <li>1 12 VDC      4 125 VDC</li> <li>2 24 VDC      5 250 VDC</li> <li>3 48 VDC</li> </ul>	<p><b>COIL HOUSING</b></p> <ul style="list-style-type: none"> <li>E Explosion-proof</li> <li>W Waterproof</li> <li>C Explosion-proof &amp; waterproof</li> <li>S Standard</li> </ul> <p><b>FLUID MEDIA TYPE</b></p> <ul style="list-style-type: none"> <li>1 Gas</li> <li>2 Liquid up to 40 SUS</li> <li>3 Liquid from 41 to 150 SUS</li> <li>4 Steam</li> <li>5 Cryogenic</li> </ul> <p><b>ORIFICE SIZES</b></p> <ul style="list-style-type: none"> <li>1 3/4"      3 3/32"</li> <li>2 1/6"      4 1/8"</li> </ul> <p><b>CONNECTION TYPE</b></p> <ul style="list-style-type: none"> <li>P NPT</li> <li>J British pipe thread</li> </ul>
--	--

# ATKOMATIC

## 14000 Series

Stainless Steel, Direct Lift, Pressure 0 to 3000 psig (207 bar)  
High Pressure Valve Configurable for Variety of Fluid Applications



### Features

- Direct acting valve
- Pressure to 3000 psig (207 bar) depending on fluid and orifice size
- Barstock construction
- Can be mounted in any orientation
- Stainless steel construction on all wetted parts: 316 for pressure containing parts and plunger material is 416 stainless that is treated for increased corrosion resistance
- Optional stem materials of PTFE, PCTFE, or 440 stainless steel
- Media temperatures from  $-423^{\circ}\text{F}$  to  $+400^{\circ}\text{F}$  ( $-253^{\circ}\text{C}$  to  $+204^{\circ}\text{C}$ )
- Will handle fluids with viscosity up to 150 SUS
- Suitable for use with wide variety of fluid including: air, gasses, liquids, hydraulic fluids, steam, cryogenic fluids, and corrosive fluids
- Ports are oriented inline or at  $90^{\circ}$  degrees (inlet on side & outlet on bottom)
- Pipe sizes from  $\frac{1}{4}''$  &  $\frac{3}{8}''$  NPT (British BSPT ports available)
- Flow orifices of  $\frac{1}{16}''$ ,  $\frac{1}{8}''$ ,  $\frac{3}{32}''$ , and  $\frac{1}{4}''$
- Cv from 0.093 to 0.40
- Compact size and relatively low current draw with AC coils
- Class H coils are standard
- Coil housings available in NEMA 1 (standard), NEMA 4 (waterproof), NEMA 7 (explosion-proof for hazardous locations), and combination NEMA 4 & 7

### Operational Pressures (No minimum pressure differential)

ORIFICE SIZE	GASES		LIQUIDS TO 40 SUS		LIQUIDS OVER 40 SUS		STEAM	
	AC	DC	AC	DC	AC	DC	AC	DC
$\frac{1}{16}$	3000 / 207 bar	3000 / 207 bar	3000 / 207 bar	3000 / 207 bar	3000 / 207 bar	3000 / 207 bar	200 / 14 bar	200 / 14 bar
$\frac{1}{8}$	2500 / 173 bar	2100 / 145 bar	2000 / 138 bar	1400 / 97 bar	1800 / 124 bar	1300 / 90 bar	200 / 14 bar	200 / 14 bar
$\frac{3}{32}$	1900 / 131 bar	1100 / 76 bar	1,400 / 97 bar	1100 / 76 bar	1000 / 69 bar	850 / 59 bar	200 / 14 bar	200 / 14 bar
$\frac{1}{4}$	450 / 31 bar	300 / 21 bar	300 / 21 bar	225 / 16 bar	275 / 19 bar	175 / 12 bar	200 / 14 bar	200 / 14 bar

### Circle Seal Controls

2301 Wardlow Circle • P.O. Box 3300 • Corona, CA 92880

Phone (951) 270-6200 Fax (951) 270-6201

www.circlesealcontrols.com • am\_sales@circlesealcontrols.com • ind\_sales@circlesealcontrols.com

atkomatic solenoid

# 14000 Series

## Dimensions, Shipping Weights and Cv Flow Factors

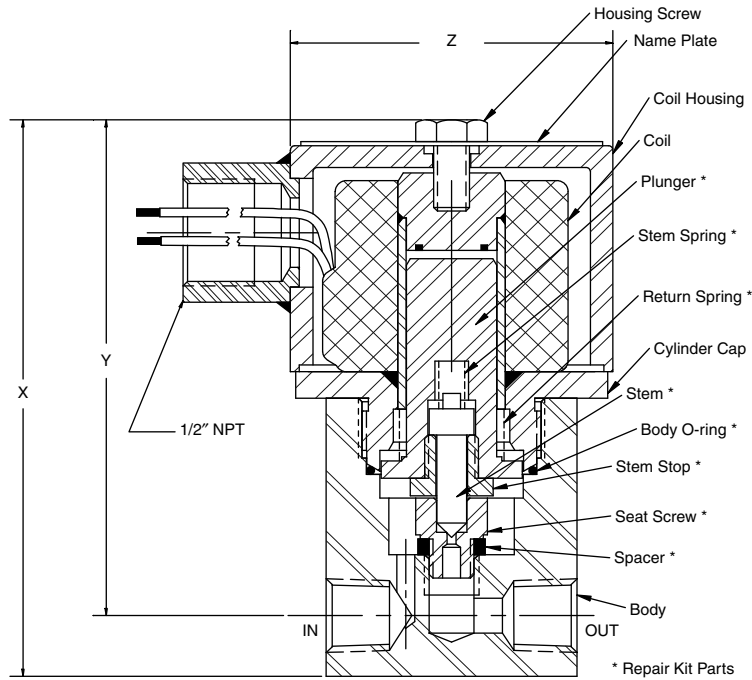

14810 3/8" valve, shown with a NEMA 7 explosion-proof coil housing & AC coil

### AC Valve

X	Y	Z	SHIPPING WEIGHT (lbs)
4"	3 3/8"	2"	4

### DC Valve

X	Y	Z	SHIPPING WEIGHT (lbs)
6 1/8"	5 3/8"	2 3/4"	6

### Cv Flow Factors

ORIFICE SIZE	Cv
1/16"	0.093
5/64"	0.15
3/32"	0.22
1/8"	0.44

CATALOG NUM. PREFIX	PIPE SIZE
14800	1/4"
14810	3/8"

## How to Order

**148** X **0** - X X X X X X X X X X X

### CONNECTION SIZE

0 1/4"      1 3/8"

### VOLTAGE AC/60 Hz

0 AC/50 Hz or DC voltage  
 1 100 VAC      4 230 VAC  
 2 115 VAC      5 460 VAC  
 3 200 VAC

### VOLTAGE AC/50 Hz

0 AC/60 Hz or DC voltage  
 1 110 VAC      2 220 VAC

### VOLTAGE DC

0 AC voltage  
 1 12 VDC      2 24 VDC      3 125 VDC

### BODY PORT LOCATION

B Inline  
 H 90°

### CONNECTION TYPE

P NPT  
 J British pipe thread

### COIL HOUSING

E Explosion-proof  
 C Combined water- & explosion-proof  
 S Standard  
 W Waterproof

### FLUID MEDIA TYPE

1 Gas  
 2 Liquid up to 40 SUS  
 3 Liquid from 41 SUS to 150 SUS  
 4 Steam  
 5 Cryogenic

### SEAL MATERIAL

A PTFE  
 B Buna N  
 C Viton®

### STEM (SEAT) MATERIAL

A PTFE  
 B PCTFE  
 C 440 stainless steel

### ORIFICE SIZE

1 1/16"      3 3/32"  
 2 5/64"      4 1/8"

Viton® is a registered trademark of DuPont Dow Elastomers.  
 PTFE is a registered trademark of DuPont.

# ATKOMATIC

## 15400 Series

Bronze, Semi-direct Lift, Pressure 0 to 300 psig (21 bar)  
Low Pressure Valve Configurable for Variety of Fluid Applications



### Features

- Semi-direct lift action for operation down to zero pressure differential
- Operation up to 300 psi (21 bar)
- Bronze valve material (naval M bronze)
- Available normally closed or normally open
- Media temperatures from  $-423^{\circ}\text{F}$  to  $+500^{\circ}\text{F}$  ( $-253^{\circ}\text{C}$  to  $+260^{\circ}\text{C}$ )
- Will handle fluids with viscosity up to 150 SUS
- Suitable for use with wide variety of fluid including: air, gasses, liquids, hydraulic fluids, steam, cryogenic fluids, and fluid not harmful to bronze
- Optional seat materials of PTFE, PCTFE, Buna N, Viton<sup>®</sup>, EPR, or metal (316 stainless steel pilot and/or brass piston seat) depending on fluid type and pressure
- Body seal materials of PTFE, Viton<sup>®</sup>, Buna N, or EPR
- Pipe sizes from  $\frac{1}{4}$ " through  $1\frac{1}{2}$ " NPT
- British BSPT ports are available
- Full ported valves: Cv from 1.1 through 21.5
- Coil housings available in NEMA 1 (standard), NEMA 4 (waterproof), NEMA 7 (explosion-proof for hazardous locations), and combination NEMA 4 & 7
- Manual opening and throttling devices are available as options
- Valve position indicator option is available
- Class B coils are available for media temperatures of  $0^{\circ}\text{F}$  through  $220^{\circ}\text{F}$
- Class H coils are available: recommended for media temperatures of  $-423^{\circ}\text{F}$  ( $-253^{\circ}\text{C}$ ) through  $+500^{\circ}\text{F}$  ( $+260^{\circ}\text{C}$ )
- Treated 416 stainless steel plunger material for increased corrosion resistance

### Operational Pressures (No minimum pressure differential)

GASES		LIQUIDS TO 40 SUS		LIQUIDS OVER 40 SUS		STEAM	
AC	DC	AC	DC	AC	DC	AC	DC
300 / 21 bar	300 / 21 bar	300 / 21 bar	300 / 21 bar	300 / 21 bar	300 / 21 bar	125 / 9 bar	125 / 9 bar

Note: Normally open valves are rated for intermittent duty only on 15000 Series valves and are not recommended for cryogenic service above 50 psig

### Circle Seal Controls

2301 Wardlow Circle • P.O. Box 3300 • Corona, CA 92880

Phone (951) 270-6200 Fax (951) 270-6201

www.circlesealcontrols.com • am\_sales@circlesealcontrols.com • ind\_sales@circlesealcontrols.com

atkomatic solenoid

# 15400 Series

## Dimensions, Shipping Weights and Cv Flow Factors

### 15400 Series Normally Closed Bronze

CATALOG NUM. PREFIX		PIPE SIZE	MAIN SEAT ORIFICE	X	Y	Z	SHIPPING WEIGHT (lbs)	Cv
CLASS B COIL	CLASS H COIL							
15400	15408	1/4"	1/2"	7 5/16"	6 1/2"	2 1/16"	5	1.4
15410	15418	3/8"	1/2"	7 5/16"	6 1/2"	2 1/16"	5	2.7
15420	15428	1/2"	1/2"	7 5/16"	6 1/2"	3"	6	3.5
15430	15438	3/4"	1"	7 15/16"	6 5/8"	3 3/4"	7	7.5
15440	15448	1"	1"	7 15/16"	6 5/8"	3 3/4"	7	9.1
—	15458	1 1/4"	1 1/2"	9 13/16"	8"	5 1/16"	20	19.5
—	15468	1 1/2"	1 1/2"	9 13/16"	8"	5 1/16"	20	21.0

Note: 1 1/4" & 1 1/2" valves have aluminum pistons (for reduced weight) and are not suitable for steam, water and other media harmful to aluminum.

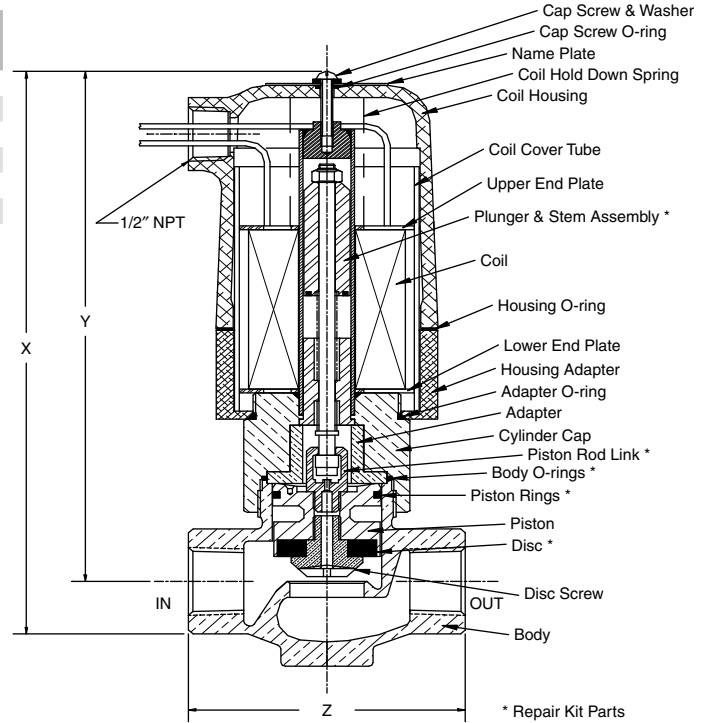

15447 1" normally open valve, shown with a waterproof NEMA 4 coil housing and a soft pilot seat

### 15400 Series Normally Open Bronze

CATALOG NUM. PREFIX		PIPE SIZE	MAIN SEAT ORIFICE	X	Y	Z	SHIPPING WEIGHT (lbs)	Cv
CLASS B COIL	CLASS H COIL							
15401	15407	1/4"	1/2"	9 3/32"	8 3/16"	2 1/16"	5	1.4
15411	15417	3/8"	1/2"	9 3/32"	8 3/16"	2 1/16"	5	2.7
15421	15427	1/2"	1/2"	9 3/16"	8 3/16"	3"	6	3.5
15431	15437	3/4"	1"	9 1/2"	8 1/4"	3 3/4"	7	7.5
15441	15447	1"	1"	9 1/2"	8 1/4"	3 3/4"	7	9.1

15448 1" normally closed valve, shown with a explosion-proof NEMA 7 coil housing and a metal pilot seat

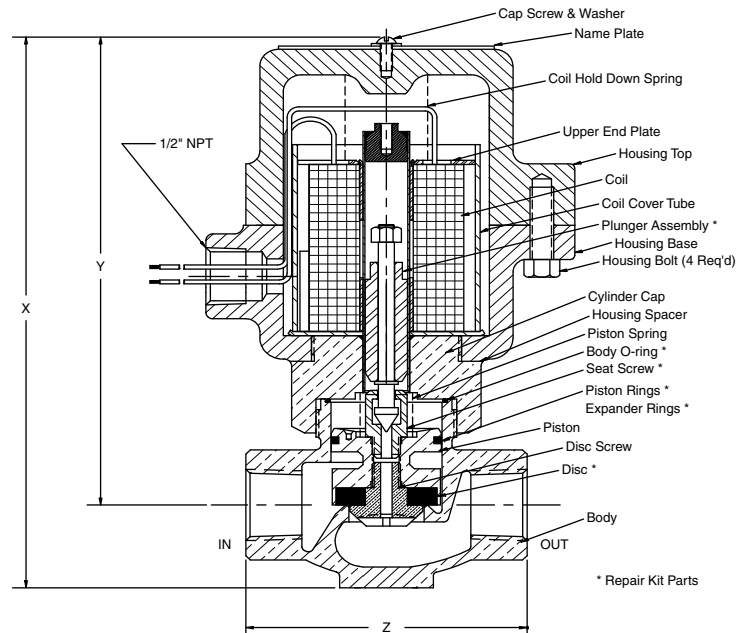



# 15400 Series

## How to Order

154 x x - x x x x x x x x x x x x

### CONNECTION SIZE

- 0 1/4" pipe      1 3/8" pipe
- 2 1/2" pipe      3 3/4" pipe
- 4 1" pipe        5 1 1/4" pipe
- 6 1 1/2" pipe

### VALVE NORMAL POSITION

- 0 Normally closed & Class B coil
- 1 Normally open & Class B coil
- 7 Normally open & Class H coil
- 8 Normally closed & Class H coil

### VOLTAGE AC/60 Hz

- 0 AC/50Hz or DC voltage
- 1 24 VAC    2 100 VAC    3 115 VAC
- 4 200 VAC    5 230 VAC    6 460 VAC

### VOLTAGE AC/50 Hz

- 0 AC/60 Hz or DC voltage
- 1 24 VAC    2 110 VAC
- 3 220 VAC    4 380 VAC

### VOLTAGE DC

- 0 AC voltage
- 1 12 VDC    2 24 VDC    3 32 VDC
- 4 72 VDC    5 125 VDC    6 250 VDC

### COIL INSULATION RATING

- B Class B (155° C)
- H Class H (180° C)

### CONNECTION TYPE

- P NPT
- J British pipe thread

### OPTIONS

- P Position indicator
- M Manual opening
- T Manual throttling

### COIL HOUSING

- E Explosion-proof
- S Standard
- W Waterproof
- C Combined water- & explosion-proof

### FLUID MEDIA TYPE

- 1 Gas
- 2 Liquid up to 40 SUS
- 3 Liquid from 41 SUS to 150 SUS
- 4 Steam
- 5 Cryogenic

### SEAL MATERIAL

- A PTFE      B Buna N
- C Viton®    D EPR

### SEAT/PILOT MATERIAL

- A TFE pilot & TFE disc
- B Buna N pilot & Buna N disc
- C Viton® pilot & Viton® disc
- D EPR pilot & EPR disc
- E PCTFE pilot & PCTFE disc
- F Metal pilot & metal disc
- G Metal pilot & TFE disc
- H Metal pilot & Buna N disc
- I Metal pilot & Viton® disc
- J Metal pilot & EPR disc
- L Metal pilot & PCTFE disc

### MAX. OPERATING PRESSURE (psig)

- A 100      E 250
- B 125      F 300
- C 150      M 50
- D 200

# ATKOMATIC

## 15800 Series

Stainless Steel, Semi-direct Lift, Pressure 0 to 1500 psig (104 bar)  
Medium Pressure Valve Configurable for Variety of Fluid Applications



atkomatic solenoid

### Features

- Stainless steel construction on all wetted parts: 316 for barstock parts and CF8M for cast parts.
- Plunger material is 416 stainless that is treated for increased corrosion resistance
- Semi-direct lift action for operation down to zero pressure differential
- Normally closed operation
- Operation up to 1500 psi (104 bar)
- Media temperatures from  $-423^{\circ}\text{F}$  to  $+500^{\circ}\text{F}$  ( $-253^{\circ}\text{C}$  to  $+260^{\circ}\text{C}$ )
- Will handle fluids with viscosity up to 150 SUS
- Suitable for use with wide variety of fluid including: air, gasses, liquids, hydraulic fluids, steam, cryogenic fluids, and corrosive fluids
- Optional pilot and piston seat materials of PTFE, PCTFE, Buna N, Viton®, EPR, or 316 stainless steel depending on fluid type and pressure
- Body seal materials of PTFE, Viton®, Buna N, or EPR
- Pipe sizes from  $\frac{1}{4}$ " through 1" NPT
- British BSPT ports are available
- Full ported valves: Cv from 1.1 through 12.5
- Removable 316 stainless steel body inserts (stainless steel trim)
- Class H coils standard
- Coil housings available in NEMA 1 (standard), NEMA 4 (waterproof), NEMA 7 (explosion-proof for hazardous locations), and combination NEMA 4 & 7
- Manual opening device is available as an option
- Valve position indicator option is available

### Operational Pressures (No minimum pressure differential)

GASES		LIQUIDS TO 40 SUS		LIQUIDS OVER 40 SUS		STEAM	
AC	DC	AC	DC	AC	DC	AC	DC
1500 / 104 bar	1500 / 104 bar	1500 / 104 bar	1000 / 69 bar	1500 / 104 bar	1000 / 69 bar	200 / 14 bar	200 / 14 bar

Note: Buna N, Viton® and EPR seats are limited to 500 psi.

### Circle Seal Controls

2301 Wardlow Circle • P.O. Box 3300 • Corona, CA 92880

Phone (951) 270-6200 Fax (951) 270-6201

www.circlesealcontrols.com • am\_sales@circlesealcontrols.com • ind\_sales@circlesealcontrols.com

# 15800 Series

## Dimensions, Shipping Weights, and Cv Flow Factors

### 15800 Series Normally Closed Stainless Steel

CATALOG NUM. PREFIX	PIPE SIZE	MAIN SEAT ORIFICE	X	Y	Z	SHIPPING WEIGHT (lbs)	Cv
15800	1/4"	3/8"	7 3/8"	6 1/2"	3"	7	1.1
15810	3/8"	3/8"	7 3/8"	6 1/2"	3"	7	2.5
15820	1/2"	3/4"	8 1/4"	7 1/8"	4 3/8"	9	5.1
15830	3/4"	3/4"	8 1/4"	7 1/8"	4 5/8"	9	7.5
15840	1"	1"	9 3/8"	7 1/16"	5 1/4"	15	12.5

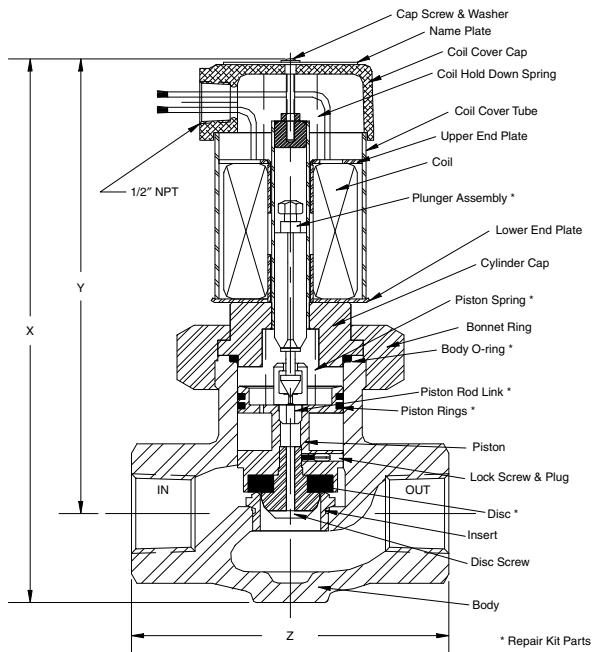

15840 1" valve, shown with a NEMA 1 coil housing and a metal pilot seat

## How to Order

**PED158** X 0 X - X X H X X X X X X X

### PED CERTIFICATION

(optional, otherwise blank)

### CONNECTION SIZE

- |               |               |
|---------------|---------------|
| 0 1/4" pipe   | 1 3/8" pipe   |
| 2 1/2" pipe   | 3 3/4" pipe   |
| 4 1" pipe     | 5 1 1/4" pipe |
| 6 1 1/2" pipe |               |

### VOLTAGE AC/60 Hz

- |                          |           |
|--------------------------|-----------|
| 0 AC/50 Hz or DC voltage |           |
| 1 24 VAC                 | 2 100 VAC |
| 3 115 VAC                | 4 200 VAC |
| 5 230 VAC                | 6 460 VAC |

### VOLTAGE AC/50 Hz

- |                          |           |
|--------------------------|-----------|
| 0 AC/60 Hz or DC voltage |           |
| 1 24 VAC                 | 2 110 VAC |
| 3 220 VAC                | 4 380 VAC |

### VOLTAGE DC

- |              |           |
|--------------|-----------|
| 0 AC voltage |           |
| 1 12 VDC     | 2 24 VDC  |
| 3 32 VDC     | 4 72 VDC  |
| 5 125 VDC    | 6 250 VDC |

### CONNECTION TYPE

- |       |                       |
|-------|-----------------------|
| P NPT | J British pipe thread |
|-------|-----------------------|

### MAX. OPERATING PRESSURE

(psig)

- |       |       |         |
|-------|-------|---------|
| A 100 | E 250 | I 700   |
| B 125 | F 300 | J 1000  |
| C 150 | G 350 | K 1,200 |
| D 200 | H 500 | L 1500  |

### OPTIONS

- P Position indicator
- M Manual opening

### COIL HOUSING

- A ATEX approved coil housing
- E Explosion-proof
- S Standard
- W Waterproof
- C Combined water- & explosion-proof

### FLUID MEDIA TYPE

- |                                 |             |
|---------------------------------|-------------|
| 1 Gas                           | 4 Steam     |
| 2 Liquid up to 40 SUS           | 5 Cryogenic |
| 3 Liquid from 41 SUS to 150 SUS |             |

### SEAL MATERIAL

- |          |          |
|----------|----------|
| A PTFE   | B Buna N |
| C Viton® | D EPR    |

### SEAT/PILOT MATERIAL

- A TFE pilot & TFE disc
- B Buna N pilot & Buna N disc
- C Viton® pilot & Viton® disc
- D EPR pilot & EPR disc
- E PCTFE pilot & PCTFE disc
- F Metal pilot & metal disc
- G Metal pilot & TFE disc
- H Metal pilot & Buna N disc
- I Metal pilot & Viton® disc
- J Metal pilot & EPR disc
- K Metal pilot & PCTFE disc

# ATKOMATIC

## 16000 Series

Stainless Steel, Direct Lift, Pressure 0 to 6000 psig (414 bar)  
High Pressure Valve Configurable for a Variety of Fluid Applications



### Features

- Direct acting valve
- Pressure to 6000 psig 414 bar depending on coil type, fluid and orifice size
- Available in normally open and normally closed versions
- Stainless steel construction on all wetted parts: 316 for machined parts and CF8M for cast parts.
- Plunger material is 416 stainless that is treated for increased corrosion resistance
- Will handle fluids with viscosity up to 200 SUS
- Media temperature from  $-423^{\circ}\text{F}$  to  $+500^{\circ}\text{F}$  ( $-253^{\circ}\text{C}$  to  $+260^{\circ}\text{C}$ )
- Suitable for use with wide variety of fluid including: air, gasses, liquids, hydraulic fluids, steam, cryogenic fluids, and corrosive fluids
- Optional seat materials of PTFE, PCTFE, Buna N, Viton<sup>®</sup>, EPR, or 316 stainless steel depending on fluid type and pressure
- Body seal materials of PTFE, Viton<sup>®</sup>, Buna N, or EPR.
- Pipe sizes from  $\frac{1}{4}$ " through 1" NPT (British BSBT ports available)
- Flow orifices of  $\frac{1}{16}$ ",  $\frac{3}{32}$ ",  $\frac{1}{8}$ ", or  $\frac{3}{16}$ "
- Cv from 0.093 to 0.72
- Class H coils standard
- Can use a class H double wound coil (requires use with a relay to drop put primary coil winding after valve actuation) depending on pressure
- Coil housings available in NEMA 1 (standard), NEMA 4 (waterproof), NEMA 7 (explosion-proof for hazardous locations), and combination NEMA 4 & 7

### Circle Seal Controls

2301 Wardlow Circle • P.O. Box 3300 • Corona, CA 92880

Phone (951) 270-6200 Fax (951) 270-6201

www.circlesealcontrols.com • am\_sales@circlesealcontrols.com • ind\_sales@circlesealcontrols.com

atkomatic solenoid

# 16000 Series

## Operational Pressures (No minimum pressure differential)

Single wound coils, metal seats, normally closed 16000–16400

ORIFICE SIZE	GASES		LIQUIDS TO 40 SUS		LIQUIDS OVER 40 SUS		STEAM	
	AC	DC	AC	DC	AC	DC	AC	DC
1/16	2500	1500	1,800	900	1500	500	300	300
3/32	1000	500	800	350	500	170	300	300
1/8	500	190	400	125	250	60	300	125
3/16	175	55	125	35	125	20	125	35

Single wound coils, PTFE - PCTFE, soft seats, normally closed 16000–16400

ORIFICE SIZE	GASES		LIQUIDS TO 40 SUS		LIQUIDS OVER 40 SUS		STEAM	
	AC	DC	AC	DC	AC	DC	AC	DC
1/16	500	500	500	500	500	340	300	300
3/32	500	425	500	300	425	150	300	300
1/8	425	160	340	100	210	40	300	100
3/16	150	50	100	30	100	12	100	30

Single wound coils, metal seats, normally open 16001–16401

ORIFICE SIZE	GASES		LIQUIDS TO 40 SUS		LIQUIDS OVER 40 SUS		STEAM	
	AC	DC	AC	DC	AC	DC	AC	DC
1/16	1,800	800	1000	350	700	300	300	300
3/32	500	250	300	150	275	90	300	150
1/8	250	100	200	50	125	35	200	50
3/16	65	25	40	15	25	10	40	15

Single wound coils, soft seats, normally open 16001–16401

ORIFICE SIZE	GASES		LIQUIDS TO 40 SUS		LIQUIDS OVER 40 SUS		STEAM	
	AC	DC	AC	DC	AC	DC	AC	DC
1/16	1500	680	850	300	600	250	300	300
3/32	425	200	250	130	230	75	300	150
1/8	200	85	170	40	100	30	170	40
3/16	55	20	85	12	20	8	85	12

Double wound coils, metal seats 16004–16404

ORIFICE SIZE	GASES		LIQUIDS TO 40 SUS		LIQUIDS OVER 40 SUS		STEAM	
	AC	DC	AC	DC	AC	DC	AC	DC
1/16	6000	4000	6000	3500	5000	2500	300	300
3/32	3500	2000	3000	1500	3000	1000	300	300
1/8	2000	800	1500	600	1,200	400	300	300
3/16	700	250	600	200	500	175	300	200

Double wound coils, soft seats 16004–16404

ORIFICE SIZE	GASES		LIQUIDS TO 40 SUS		LIQUIDS OVER 40 SUS		STEAM	
	AC	DC	AC	DC	AC	DC	AC	DC
1/16	6000	4000	5500	3000	4,250	2,100	300	300
3/32	3000	1,700	2,600	1,300	2,250	850	300	300
1/8	1,700	680	1,275	500	1000	425	300	300
3/16	600	200	500	170	425	150	300	170

Note: Normally open valves are rated for intermittent duty only on 16000 Series valves.

Note: Buna N, Viton® and EPR seats are limited to 500 psig (34.5 barg).

# 16000 Series

## Dimensions and Shipping Weights

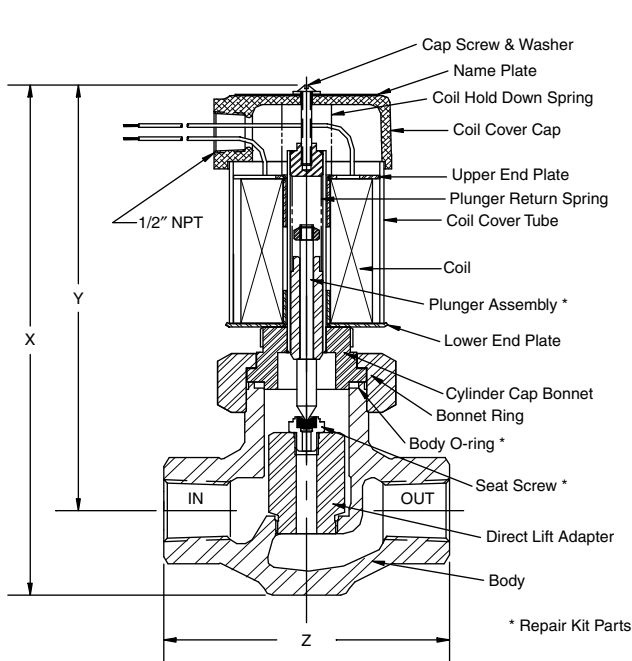

Normally closed 16200 1/2" valve,  
shown with a NEMA 1 coil housing and a soft seat

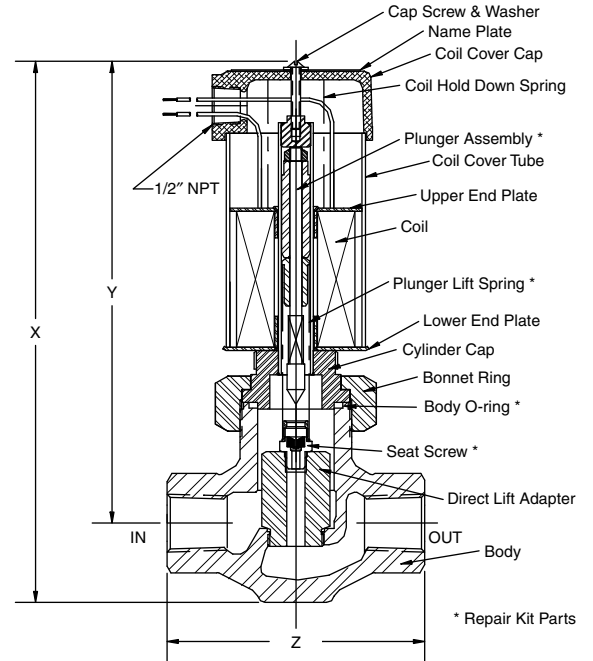

Normally open 16201 1/2" valve,  
shown with a NEMA 1 coil housing and a soft seat

### 16000 Series Normally Closed, Single and Double Wound Coils

CATALOG NUM. PREFIX		PIPE SIZE	X	Y	Z	SHIPPING WEIGHT (lbs)
SINGLE WOUND COIL	DOUBLE WOUND COIL					
16000	16004	1/4"	7"	6 1/8"	3"	6
16100	16104	3/8"	7"	6 1/8"	3"	6
16200	16204	1/2"	8 1/2"	7 3/8"	4 3/8"	9
16300	16304	3/4"	8 1/2"	7 3/8"	4 3/8"	9
16400	16404	1"	9 3/16"	7 1/16"	5 1/4"	14

### 16000 Series Normally Open, Single Wound Coils Only

CATALOG NUM. PREFIX	PIPE SIZE	X	Y	Z	SHIPPING WEIGHT (lbs)
16001	1/4"	8 1/8"	7 3/16"	3"	6
16101	3/8"	8 1/8"	7 3/16"	3"	6
16201	1/2"	9 5/8"	8 1/2"	4 5/8"	9
16301	3/4"	9 5/8"	8 1/2"	4 3/8"	9
16401	1"	10 3/16"	8 13/16"	5 1/4"	14

### Cv Flow Factors

ORIFICE SIZE	Cv
1/16"	0.093
3/32"	0.22
1/8"	0.44
3/16"	0.72

# 16000 Series

## How to Order

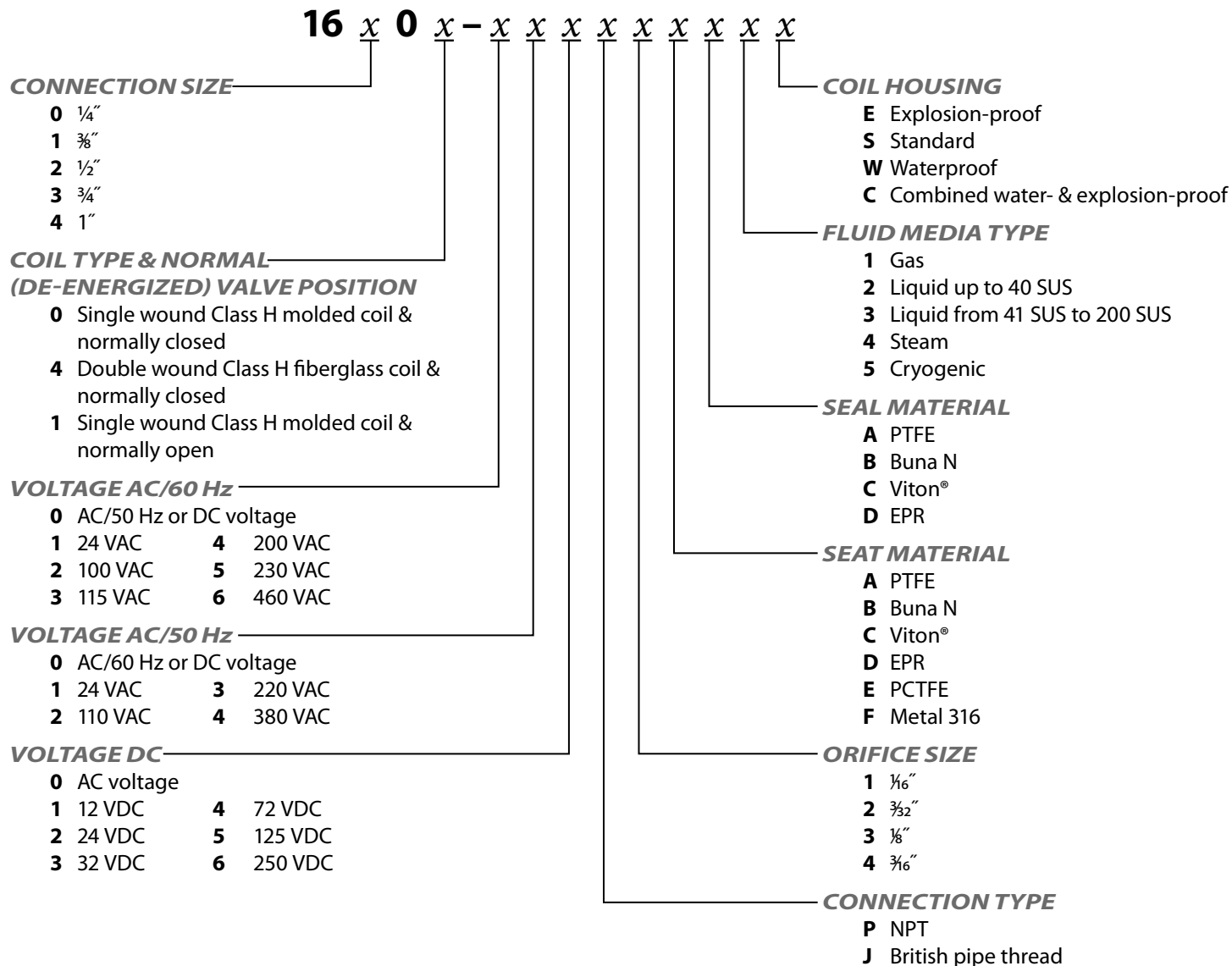

Viton® is a registered trademark of DuPont Dow Elastomers.  
PTFE is a registered trademark of DuPont.

# ATKOMATIC

## 30400 Series

Bronze, Semi-direct Lift, Pressure 0 to 1500 psig (104 bar)  
Medium Pressure Valve, Configurable for a Variety of Fluid Applications



atkomatic solenoid

### Features

- Semi-direct lift action for operation down to zero pressure differential
- Operation up to 1500 psig (104 bar)
- Media temperatures from  $-423^{\circ}\text{F}$  to  $+500^{\circ}\text{F}$  ( $-253^{\circ}\text{C}$  to  $+260^{\circ}\text{C}$ )
- Will handle fluids with viscosity up to 150 SUS
- Bronze valve material (naval M bronze)
- Suitable for use with wide variety of fluid including: air, gasses, liquids, hydraulic fluids, steam, cryogenic fluids, and fluids not harmful to bronze
- Heaviest duty and most rugged construction
- Optional seat materials of PTFE, PCTFE, Buna N, Viton<sup>®</sup>, EPR, or metal (316 stainless steel pilot and/or brass piston seat) depending on fluid type and pressure
- Body seal materials of PTFE, Viton<sup>®</sup>, Buna N, or EPR
- Removable 316 stainless steel body inserts (stainless steel trim)
- Available in normally closed configuration from  $\frac{1}{4}$ " to 3" NPT ports
- Available in normally open configuration from  $\frac{1}{4}$ " to  $1\frac{1}{2}$ " NPT ports
- British BSPT ports available
- Full ported valves
- Normally closed Cv from 2.7 to 71
- Normally open Cv from 2.7 to 21
- Class H coils are standard
- Coil housings available in NEMA 1 (standard), NEMA 4 (waterproof), NEMA 7 (explosion-proof for hazardous locations), and combination NEMA 4 & 7
- Manual opening and throttling devices are available as options (requires aluminum piston on  $2\frac{1}{2}$ " & 3")
- Valve position indicator option is available

### Circle Seal Controls

2301 Wardlow Circle • P.O. Box 3300 • Corona, CA 92880

Phone (951) 270-6200 Fax (951) 270-6201

www.circlesealcontrols.com • am\_sales@circlesealcontrols.com • ind\_sales@circlesealcontrols.com



# 30400 Series

## Operational Pressures (No minimum pressure differential)

Normally closed, 1/4"– 1 1/2"

GASES		LIQUIDS TO 40 SUS		LIQUIDS OVER 40 SUS		STEAM	
AC	DC	AC	DC	AC	DC	AC	DC
1500	1000	1500	1000	1500	1000	200	200

Normally closed, 2"–3"

GASES		LIQUIDS TO 40 SUS		LIQUIDS OVER 40 SUS		STEAM	
AC	DC	AC	DC	AC	DC	AC	DC
500	500	500	350	500	350	200	100

Normally open, 1/4"– 1 1/2"

GASES		LIQUIDS TO 40 SUS		LIQUIDS OVER 40 SUS		STEAM	
AC	DC	AC	DC	AC	DC	AC	DC
1500	1500	1500	1500	1500	1,250	200	200

NOTE 1: Normally open valves are rated for intermittent duty only on 30000 Series valves and are not recommended for cryogenic service above 50 psig.

NOTE 2: Buna N, Viton® and EPR seats are limited to 500 psig (34.5 barg).

## Dimensions, Shipping Weights, and Cv Flow Factors

### 30400 Series Normally Open Bronze

CATALOG NUM.	PIPE SIZE	MAIN SEAT ORIFICE	X	Y	Z	SHIPPING WEIGHT (lbs)	Cv
32400	1/4"	3/8"	8 5/8"	7 3/4"	2 1/16"	10	1.4
32410	3/8"	3/8"	8 5/8"	7 3/4"	2 1/16"	10	2.7
32420	1/2"	1/2"	8 3/4"	7 13/16"	3"	10	3.5
32430	3/4"	1"	9 3/8"	8 1/16"	4"	12	8.4
32440	1"	1"	9 3/8"	8 1/16"	4"	12	9.5
32450	1 1/4"	1 1/2"	10 1/2"	8 7/8"	5 1/16"	26	19.5
32460	1 1/2"	1 1/2"	10 1/2"	8 7/8"	5 1/16"	26	21.0

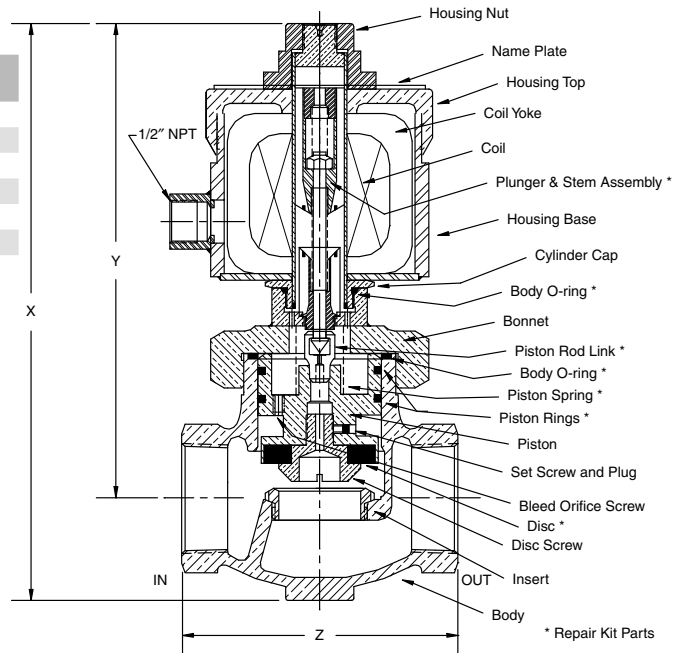

Normally open 1 1/2" 32460 valve, shown with explosion-proof NEMA 7 coil, housing and AC coil.

# 30400 Series

## Dimensions, Shipping Weights, and Cv Flow Factors

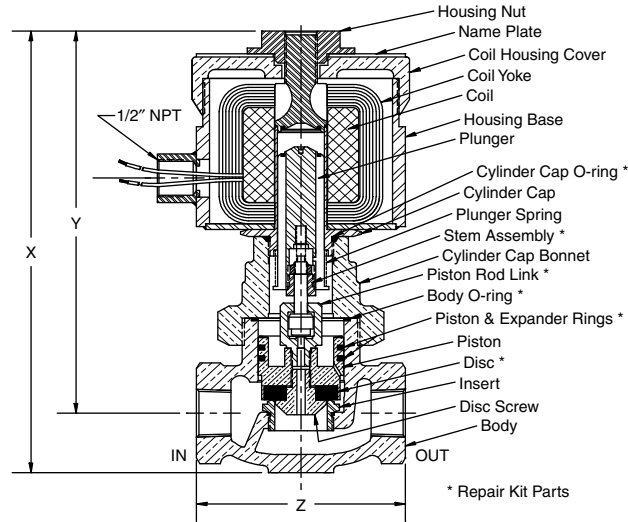

Normally closed 1" 31440 valve,  
shown with explosion-proof NEMA 7 coil. Housing an AC coil, and a soft  
pilot seat.

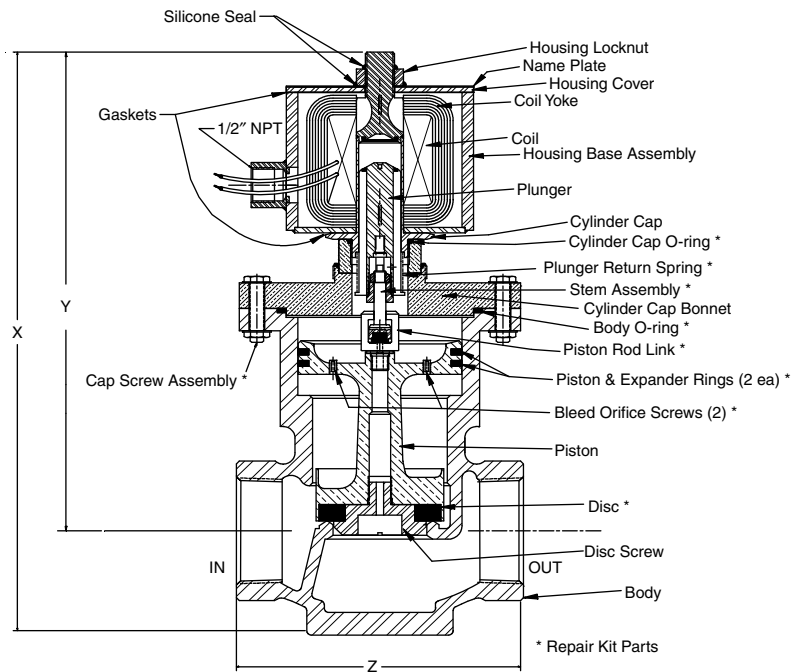

Normally closed 2" 31570 valve,  
shown with NEMA 4 coil. Housing an AC coil, and a soft pilot seat.

### 30400 Series Normally Closed Bronze

CATALOG NUM. PREFIX	PIPE SIZE	MAIN SEAT ORIFICE	X	Y	Z	SHIPPING WEIGHT (lbs)	Cv
31400	1/4"	3/8"	7 7/8"	7"	2 1/16"	10	1.4
31410	3/8"	3/8"	7 7/8"	7"	2 1/16"	10	2.7
31420	1/2"	1/2"	8"	7 1/8"	3"	10	3.5
31430	3/4"	1"	8 5/8"	7 3/8"	4"	12	8.4
31440	1"	1"	8 5/8"	7 3/8"	4"	12	9.5
31450	1 1/4"	1 1/2"	10 5/8"	8 3/4"	5 1/16"	26	19.5
31460	1 1/2"	1 1/2"	10 5/8"	8 3/4"	5 1/16"	26	21.0
31570	2"	2"	13 3/16"	10 9/16"	6 1/8"	38	43.0
31580	2 1/2"	3"	14 1/4"	10 3/8"	8 1/2"	76	63.0
31590	3"	3"	14 1/4"	10 3/8"	8 1/2"	76	71.0

# 30400 Series

## How to Order

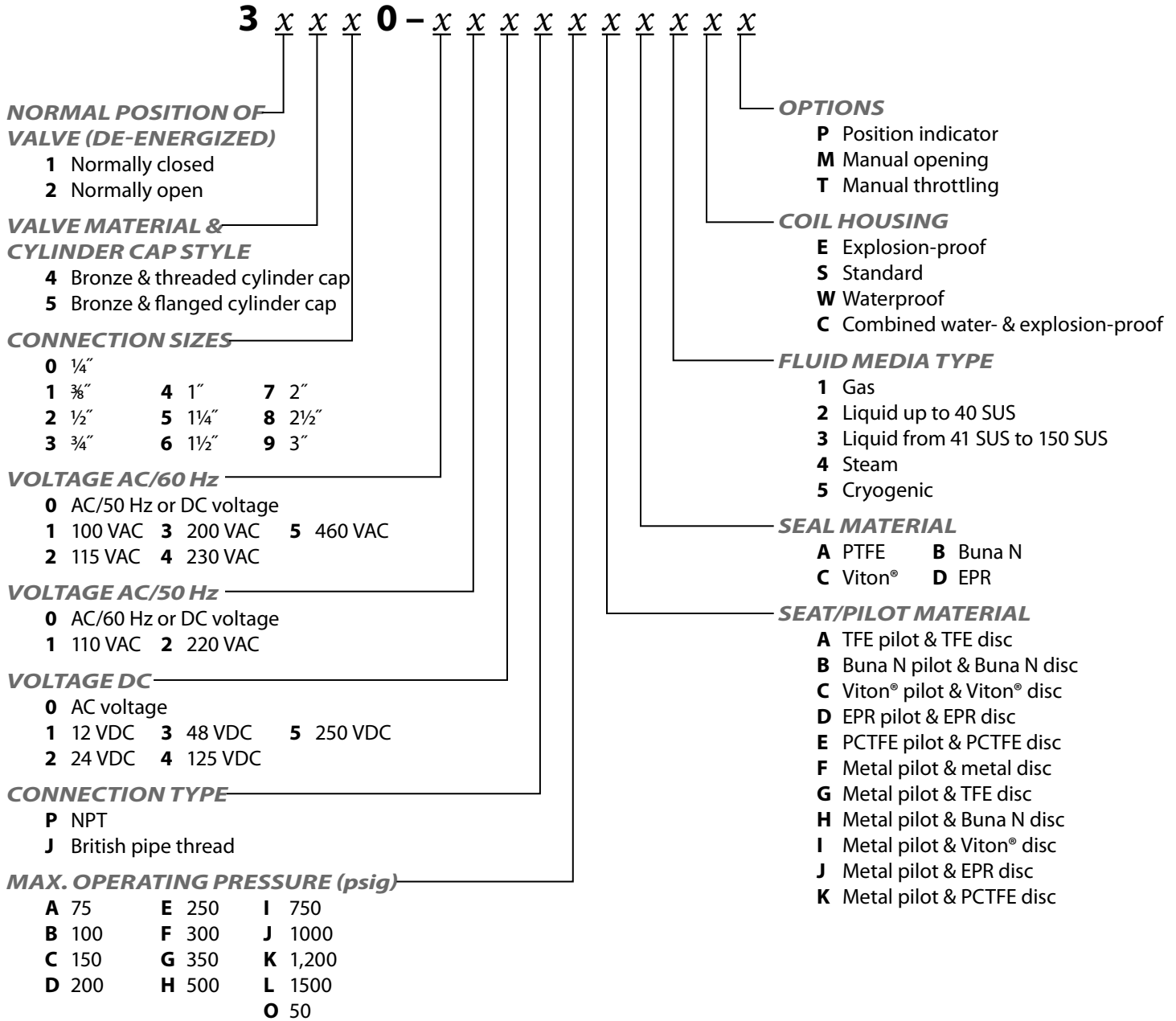

Viton® is a registered trademark of DuPont Dow Elastomers.  
PTFE is a registered trademark of DuPont.

# ATKOMATIC

## 30800 Series

Stainless Steel, Semi-direct Lift, Pressure 0 to 3000 psig (207 bar)  
High Pressure Valve Configurable for a Variety of Fluid Applications



atkomatic solenoid

### Features

- Stainless steel construction on all wetted parts: 316 for machined parts and CF8M for cast parts
- Plunger material is 416 stainless that is treated for increased corrosion resistance
- Semi-direct lift action for operation down to zero pressure differential
- Operation up to 3000 psig (207 bar)
- Media temperatures from  $-423^{\circ}\text{F}$  to  $+500^{\circ}\text{F}$  ( $-253^{\circ}\text{C}$  to  $+260^{\circ}\text{C}$ )
- Will handle fluids with viscosity up to 150 SUS
- Suitable for use with wide variety of fluid including: air, gasses, liquids, hydraulic fluids, steam, cryogenic fluids, and corrosive fluids
- Optional seat materials of PTFE, PCTFE, Buna N, Viton<sup>®</sup>, EPR, or metal (316 pilot seat and/or 316 piston seat) depending on fluid type and pressure
- Body seal materials of PTFE, Viton<sup>®</sup>, Buna N, or EPR
- Heaviest duty and most rugged construction
- Removable 316 stainless steel body inserts (stainless steel trim)
- Available in normally closed configuration from  $\frac{1}{4}$ " to 2" ports
- Available in normally open configuration from  $\frac{1}{4}$ " to  $1\frac{1}{2}$ " ports
- British BSPT ports are available
- Full ported valves
- Cv from 2.5 to 45 in normally closed valves
- Cv from 2.5 to 21.5 in normally open valves
- Class H coils are standard
- Coil housings available in NEMA 1 (standard), NEMA 4 (waterproof), NEMA 7 (explosion-proof for hazardous locations), and combination NEMA 4 & 7
- Manual opening device is available as an option
- Valve position indicator option is available

### Circle Seal Controls

2301 Wardlow Circle • P.O. Box 3300 • Corona, CA 92880

Phone (951) 270-6200 Fax (951) 270-6201

www.circlesealcontrols.com • am\_sales@circlesealcontrols.com • ind\_sales@circlesealcontrols.com

# 30800 Series

## Operational Pressures (No minimum pressure differential)

Normally closed, 1/4"-1", 31800-31860

GASES		LIQUIDS TO 40 SUS		LIQUIDS OVER 40 SUS		STEAM	
AC	DC	AC	DC	AC	DC	AC	DC
3000	1500	3000	1000	3000	1000	300	300

Normally closed, 1 1/4"-2" with threaded cylinder cap, 31851-31871

GASES		LIQUIDS TO 40 SUS		LIQUIDS OVER 40 SUS		STEAM	
AC	DC	AC	DC	AC	DC	AC	DC
1500	1500	1500	1000	1500	1000	300	300

Normally open, 1/4"-1", 32800-32860

GASES		LIQUIDS TO 40 SUS		LIQUIDS OVER 40 SUS		STEAM	
AC	DC	AC	DC	AC	DC	AC	DC
3000	2000	3000	1500	3000	1,250	300	300

Normally open, 1 1/4"-2" with threaded cylinder cap, 32851-32871

GASES		LIQUIDS TO 40 SUS		LIQUIDS OVER 40 SUS		STEAM	
AC	DC	AC	DC	AC	DC	AC	DC
1500	1500	1500	1000	1500	1000	300	300

Note: Normally open valves are rated for intermittent duty only on 30000 Series valves and are not recommended for cryogenic service above 50 psig.

Note: Normally open 30000 Series valves are not available with 50 Hz coils for operational pressures above 1500 psi.

Note: Buna N, Viton® and EPR seats are limited to 500 psi

## Dimensions, Shipping Weights, and Cv Flow Factors

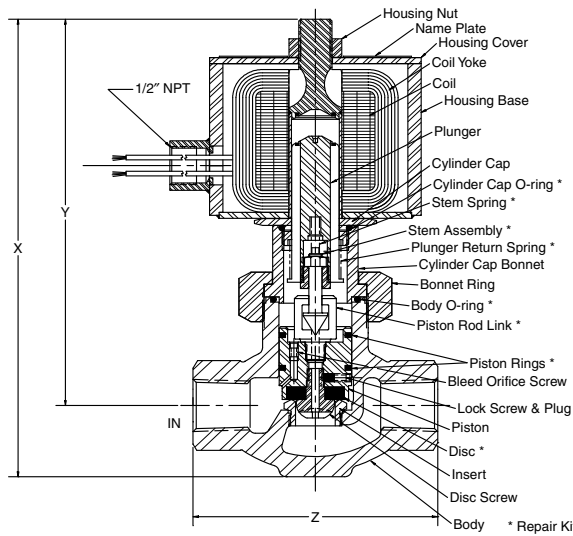

Normally closed 3/4" 31830 valve, shown with NEMA 1 coil housing, AC coil and a metal seat

### 30800 Series Normally Closed Stainless Steel

CATALOG NUM.	PIPE SIZE	MAIN SEAT ORIFICE	X	Y	Z	SHIPPING WEIGHT (lbs)	Cv
31800	1/4"	3/16"	8 1/16"	7 1/16"	3"	10	1.1
31810	3/8"	3/8"	8 1/16"	7 1/16"	3"	10	2.5
31820	1/2"	3/4"	8 1/16"	7 7/16"	4 3/8"	13	5.1
31830	3/4"	3/4"	8 1/16"	7 7/16"	4 7/8"	13	7.5
31840	1"	1"	9 1/2"	8 3/8"	5 1/4"	19	12.5
31850	1 1/4"	1 1/2"	10 1/2"	8 3/8"	7 3/8"	50	21.0
31860	1 1/2"	1 1/2"	10 1/2"	8 3/8"	7 3/8"	50	21.5
31851	1 1/4"	1 1/2"	10 3/16"	8 3/8"	5 7/8"	22	21.0
31861	1 1/2"	1 1/2"	10 3/16"	8 3/8"	5 7/8"	22	21.5
31871	2"	2"	12 3/8"	9 1/16"	7"	32	45.0

Note: 1 1/4" & 1 1/2" valve models 31850 and 31860 are rated for 3000 psig, constructed with a flanged body & cylinder cap and models 31851, 31861, and 31871 are constructed with a threaded cylinder cap & body and are rated for 1500 psi.

### 30800 Series Normally Open Stainless Steel

CATALOG NUM.	PIPE SIZE	MAIN SEAT ORIFICE	X	Y	Z	SHIPPING WEIGHT (lbs)	Cv
32800	1/4"	3/16"	8 3/8"	7 3/8"	3"	10	1.1
32810	3/8"	3/8"	8 3/8"	7 3/8"	3"	10	2.5
32820	1/2"	3/4"	9 1/2"	8"	4 3/8"	13	5.1
32830	3/4"	3/4"	9 1/2"	8"	4 3/8"	13	7.3
32840	1"	1"	10 1/2"	8 3/8"	5 1/4"	19	12.5
32851	1 1/4"	1 1/2"	10 1/2"	8 1/2"	5 7/8"	22	21.0
32861	1 1/2"	1 1/2"	10 1/2"	8 1/2"	5 7/8"	22	21.5

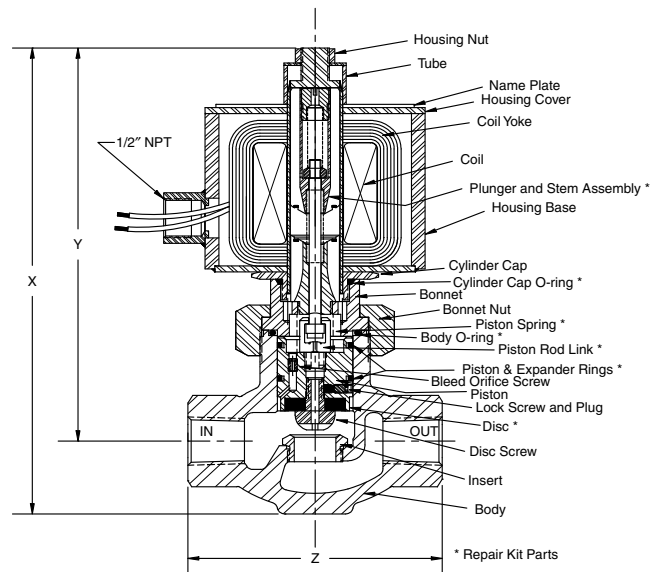

Normally open 3/4" 32830 valve, shown with NEMA 1 coil housing, AC coil and a soft pilot seat

# 30800 Series

## How to Order

**PED3** x **8** x x - x x x x x x x x x x x x

**PED CERTIFICATION**  
(optional, otherwise blank)

**NORMAL POSITION OF VALVE (DE-ENERGIZED)**  
**1** Normally closed  
**2** Normally open

**CONNECTION SIZES**  
**0** ¼"  
**1** ⅜"    **4** 1"    **7** 2"  
**2** ½"    **5** 1¼"    **8** 2½"  
**3** ¾"    **6** 1½"    **9** 3"

**BODY STYLE**  
**0** Threaded cylinder cap on ¼"-1" and flanged cylinder cap on 1¼"-1½" (3000 psig)  
**1** Screwed cylinder cap on 1¼"-2" (1500 psig)

**VOLTAGE AC/60 Hz**  
**0** AC/50 Hz or DC voltage  
**1** 100 VAC    **3** 200 VAC    **5** 460 VAC  
**2** 115 VAC    **4** 230 VAC

**VOLTAGE AC/50 Hz**  
**0** AC/60 Hz or DC voltage  
**1** 110 VAC    **2** 220 VAC

**VOLTAGE DC**  
**0** AC voltage  
**1** 12 VDC    **3** 48 VDC    **5** 250 VDC  
**2** 24 VDC    **4** 125 VDC

**CONNECTION TYPE**  
**P** NPT  
**J** British pipe thread

**MAX. OPERATING PRESS (psig)**  
**A** 75    **F** 300    **K** 1,200  
**B** 100    **G** 350    **L** 1500  
**C** 150    **H** 500    **M** 3000  
**D** 200    **I** 750    **N** 2000  
**E** 250    **J** 1000    **O** 50

**OPTIONS**  
**P** Position indicator  
**M** Manual opening

**COIL HOUSING**  
**A** ATEX approved coil housing  
**E** Explosion-proof  
**S** Standard  
**W** Waterproof  
**C** Combined water- & explosion-proof

**FLUID MEDIA TYPE**  
**1** Gas  
**2** Liquid up to 40 SUS  
**3** Liquid from 41 SUS to 150 SUS  
**4** Steam  
**5** Cryogenic

**SEAL MATERIAL**  
**A** PTFE                    **B** Buna N  
**C** Viton®                 **D** EPR

**SEAT/PILOT MATERIAL**  
**A** TFE pilot & TFE disc  
**B** Buna N pilot & Buna N disc  
**C** Viton® pilot & Viton® disc  
**D** EPR pilot & EPR disc  
**E** PCTFE pilot & PCTFE disc  
**F** Metal pilot & metal disc  
**G** Metal pilot & TFE disc  
**H** Metal pilot & Buna N disc  
**I** Metal pilot & Viton® disc  
**J** Metal pilot & EPR disc  
**K** Metal pilot & PCTFE disc

Viton® is a registered trademark of DuPont Dow Elastomers.  
 PTFE is a registered trademark of DuPont.

# ATKOMATIC

## 35800 Series

Stainless Steel, Pilot-piston, Pressure 35 to 2000 psig (2.4 to 138 bar)  
High Pressure Valve Configurable for Variety of Fluid Applications

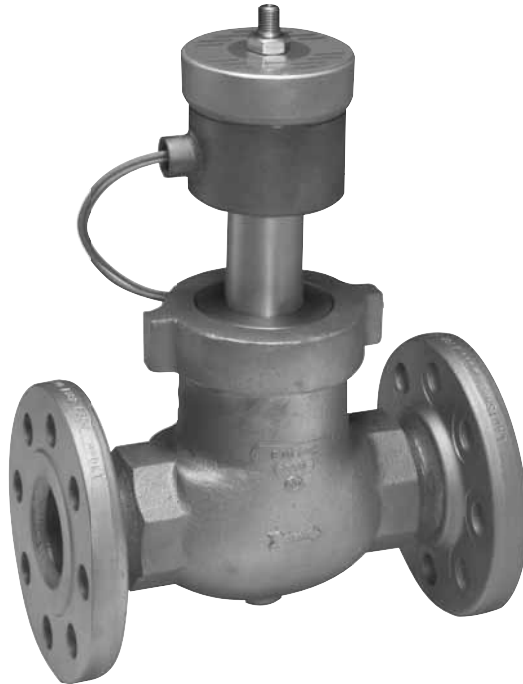

### Features

- Rapid response time: achieved by use of an external pilot source
- Pilot operated valve
- Operation up to 2000 psig (138 bar)
- Stainless steel construction on all wetted parts: 316 for machined parts and CF8M for cast parts.
- Plunger material is 416 stainless that is treated for increased corrosion resistance
- Available in 1/2" through 2" NPT pipe size
- Full ported valves; heavy duty, rugged construction
- Cv from 5.1 to 45
- British BSPT ports available
- Media temperatures from -15° F to +400° F (-26° C to 204° C)
- Optional piston seat materials of PTFE, PCTFE, Buna N, Viton®, EPR, or 316 stainless steel depending on fluid type and pressure
- Body seal materials of PTFE, Viton®, Buna N, or EPR
- Piston lip seals are Viton®
- Optional piston seat materials of PTFE, PCTFE, Buna N, Viton®, EPR or 316 stainless steel depending on fluid type and pressure.
- Removable 316 stainless steel body inserts (stainless steel trim)
- Will handle fluids with viscosity up to 150 SUS
- Suitable for use with wide variety of fluid including: air, gasses, liquids, hydraulic fluids, cryogenic fluids, and corrosive fluids
- Class H coils are standard
- Coil housings available in NEMA 1 (standard), NEMA 4 (waterproof), NEMA 7 (explosion-proof for hazardous locations), and combination NEMA 4 & 7
- Manual opening and throttling devices are available as options
- Valve position indicator option is available

### Circle Seal Controls

2301 Wardlow Circle • P.O. Box 3300 • Corona, CA 92880

Phone (951) 270-6200 Fax (951) 270-6201

www.circlesealcontrols.com • am\_sales@circlesealcontrols.com • ind\_sales@circlesealcontrols.com

atkomatic solenoid

# 35800 Series

## Operational Pressures (35 psid minimum pressure differential)

Normally closed and open 1/2"-1", 35820-35840

GASES		LIQUIDS TO 40 SUS		LIQUIDS OVER 40 SUS	
AC	DC	AC	DC	AC	DC
2000 / 138 bar	2000 / 138 bar	2000 / 138 bar	2000 / 138 bar	1200 / 83 bar	1200 / 83 bar

Normally closed and open 1 1/4"-2", 35851-35871

GASES		LIQUIDS TO 40 SUS		LIQUIDS OVER 40 SUS	
AC	DC	AC	DC	AC	DC
2000 / 138 bar	2000 / 138 bar	2000 / 138 bar	2000 / 138 bar	1200 / 83 bar	1200 / 83 bar

Note: Both the pilot inlet and pilot exhaust ports are 1/4" NPT male and female respectively.

Note: On normally open valves the position of the pilot inlet and exhaust are reversed.

## Dimensions, Shipping Weights, and Cv Flow Factors

### 35800 Series Normally Closed or Normally Open Stainless Steel

CATALOG NUM. PREFIX	PIPE SIZE	MAIN SEAT ORIFICE	X	Y	Z	SHIPPING WEIGHT (lbs)	Cv
35820	1/2"	3/4"	11 1/16"	10 1/4"	4 5/8"	15	5.1
35830	3/4"	3/4"	11 1/16"	10 1/4"	4 5/8"	15	7.5
35840	1"	1"	12 3/8"	10 1/16"	5 1/4"	21	12.5
35851	1 1/4"	1 1/2"	12 3/16"	10 5/16"	5 7/8"	25	21.0
35861	1 1/2"	1 1/2"	12 3/16"	10 5/16"	5 7/8"	25	21.5
35871	2"	2"	14 7/8"	12 3/8"	7"	34	45.0

Note: Restrictions that apply to other normally open valves do not affect the 35800 Series normally open valves.

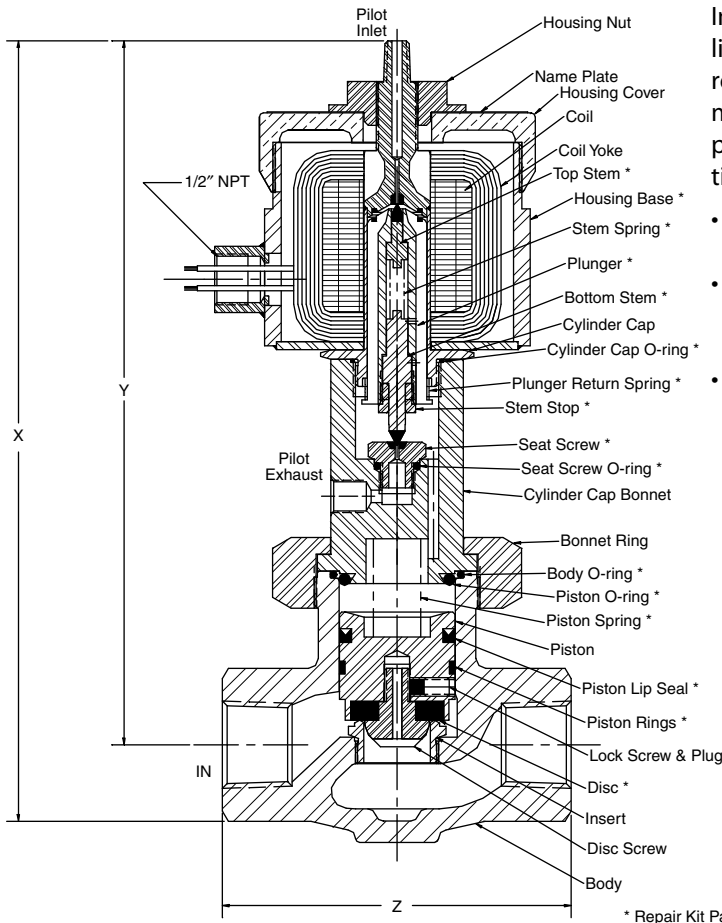

35840 1" valve, shown as a normally closed valve, with a NEMA 7 coil housing, and AC coil.

In most systems, pilot pressure is tapped off the valve's inlet line and pilot exhaust is routed to atmosphere or a low pressure receptacle. Independent sources for pilot pressure are also commonly used and occasionally the valve's outlet pipe is used for pilot exhaust. For valve operation, the following minimum conditions must be met:

- For opening, pilot exhaust pressure must be at least 35 psi less than the valve's inlet pressure.
- For closing, pilot pressure must be at least equal to the valve's inlet pressure and at least 35 psi greater than the valve's outlet pressures.
- The fastest operational speeds are obtained at maximum pressure differentials.



# 35800 Series

## How to Order

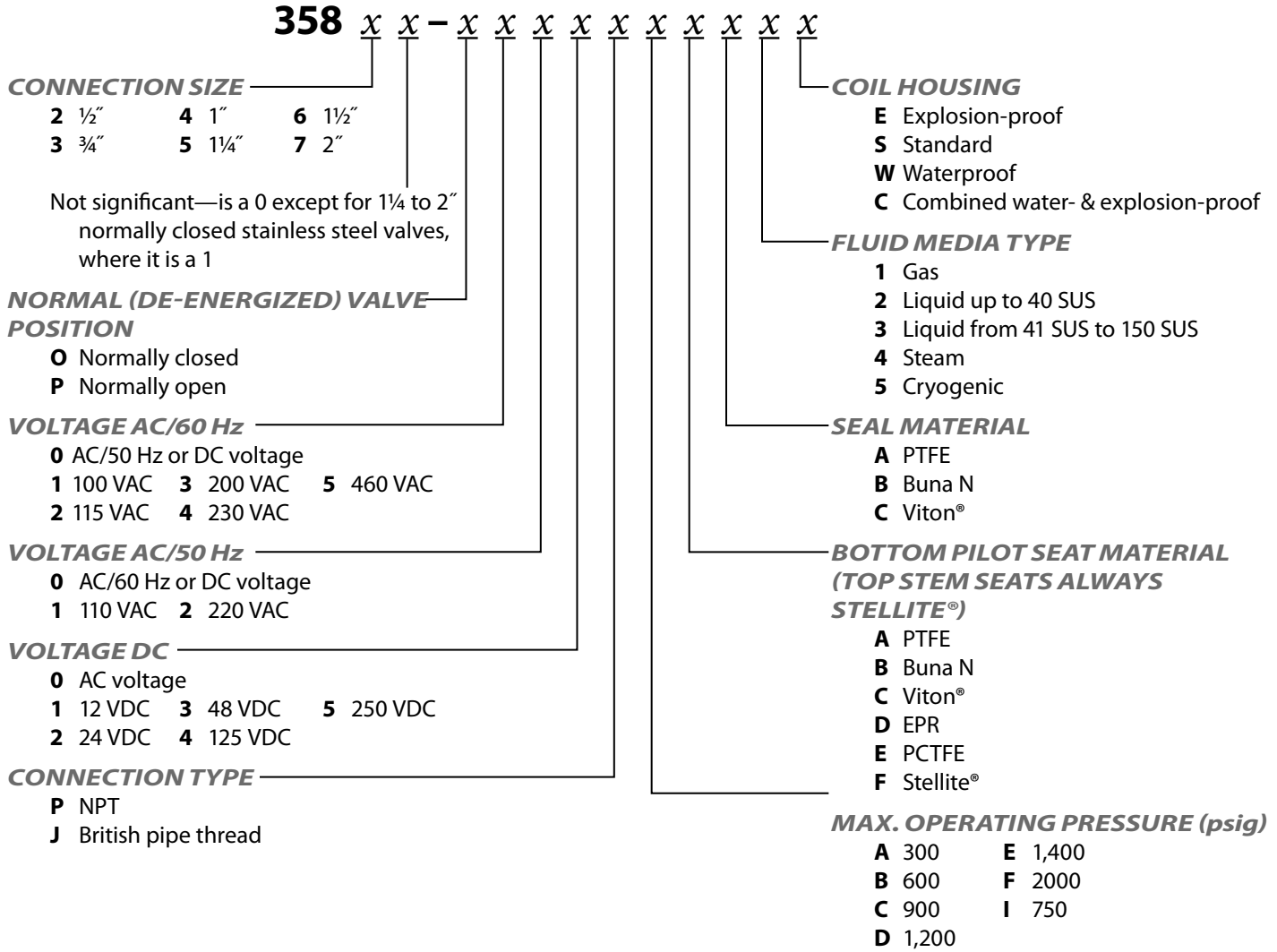

Viton® is a registered trademark of DuPont Dow Elastomers.  
 PTFE is a registered trademark of DuPont.  
 Stellite® is a registered trademark of Deloro Stellite Company Inc.

# ATKOMATIC

## 40000 Series

Stainless Steel, Semi-direct Lift, Pressure 0 to 2500 psig (173 bar)  
High Temperature High Pressure Valve Configurable for a Variety of Fluid Applications



### Features

- Designed for high temperature fluids, maximum nominal temperature rating of 750° F (399° C)
- Operational pressure up to 2500 psi (173 bar)
- Extended neck to locate the solenoid at a distance from the hot fluid flow
- Carbon graphite piston rings
- 316 stainless steel body o-rings
- Pilot seats are made of Stellite® (a cobalt alloy) for temperature and wear resistance
- Piston is made of 17-4 stainless steel and the piston seat is Stellite®
- Available in normally open and normally closed versions
- Mounted with the coil oriented down to minimize convection heating of coil from the hot media
- Stainless steel construction on all pressure containing parts: 316 for machined parts and CF8M for cast parts.
- Plunger material is 416 stainless that is treated for increased corrosion resistance
- Semi-direct lift action for operation down to zero pressure differential
- Will handle fluids with viscosity up to 150 SUS
- Suitable for use with wide variety of fluid including: air, gasses, liquids, hydraulic fluids, steam, and corrosive fluids
- Heaviest duty and most rugged construction
- Removable 316 stainless steel body inserts (stainless steel trim)
- Full ported valves
- Available in normally closed configuration from ¼" to 1½" ports
- Cv from 1.1 to 21.5 in normally closed version
- Available in normally open configuration from ¼" to 1" ports
- Cv from 1.1 to 21.0 in normally open version
- British BSPT ports are available
- Class H coils are standard
- Coil housings available in NEMA 1 (standard), NEMA 4 (waterproof), NEMA 7 (explosion-proof for hazardous locations), and combination NEMA 4 & 7

### Circle Seal Controls

2301 Wardlow Circle • P.O. Box 3300 • Corona, CA 92880

Phone (951) 270-6200 Fax (951) 270-6201

www.circlesealcontrols.com • am\_sales@circlesealcontrols.com • ind\_sales@circlesealcontrols.com

atkomatic solenoid

# 40000 Series

## Operational Pressures (No minimum pressure differential)

Normally closed

ALL GASES		ALL LIQUIDS	
AC	DC	AC	DC
2500 / 173 bar	1500 / 104 bar	2500 / 173 bar	1000 / 69 bar

Normally open

ALL GASES		ALL LIQUIDS	
AC	DC	AC	DC
2500 / 173 bar	2000 / 138 bar	2500 / 173 bar	1500 / 104 bar

Note: The operational pressure is limited to a maximum of 1500 psi (104 bar) when the fluid temperature is between 650° F and 750° F (+343° C and +399° C). The operational pressure is limited to a maximum of 2000 psi (133 bar) when the fluid temperature is between 550° F and 650° F (+288° C and +343° C). For fluid temperatures below 550° F (+288° C) the operational pressure is 2000 psi (138 bar) maximum.

Note: Normally open valves are rated for intermittent duty only on 40000 Series valves.

Note: Normally open 40000 Series valves are not available with 50 Hz coils for operational pressures above 1500 psi (104 bar).

## Dimensions, Shipping Weights, and Cv Flow Factors

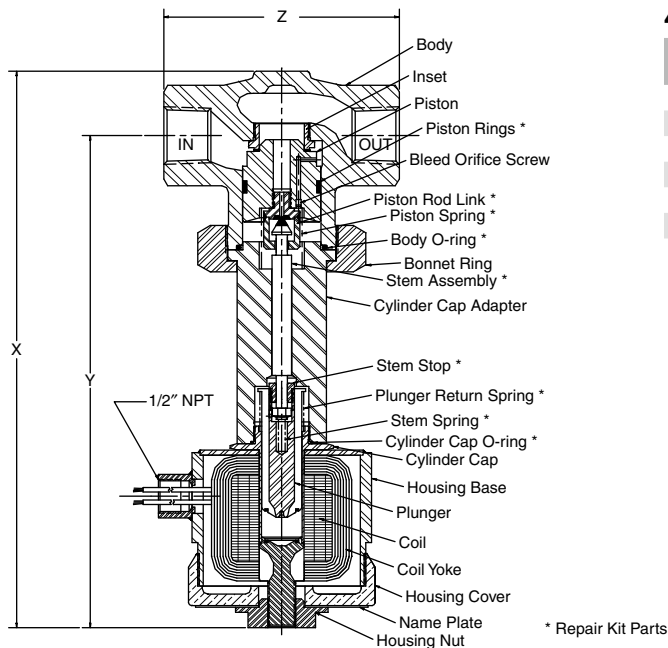

Normally closed 1" 41840 valve, shown with NEMA 7 explosion-proof coil housing and a AC coil

### 40000 Series Normally Closed

CATALOG NUM. PREFIX	PIPE SIZE	MAIN SEAT ORIFICE	X	Y	Z	SHIPPING WEIGHT (lbs)	Cv
41800	1/4"	3/8"	11 3/8"	10 9/16"	3"	14	1.1
41810	3/8"	1/2"	11 3/8"	10 9/16"	3"	14	2.5
41820	1/2"	3/4"	12 5/16"	10 7/8"	4 3/8"	17	5.1
41830	3/4"	3/4"	12 5/16"	10 7/8"	4 3/8"	17	7.5
41840	1"	1"	12 1/2"	11 1/4"	5 1/4"	23	12.5
41851	1 1/4"	1 1/2"	13 3/8"	13 1/8"	5 7/8"	22	21.0
41861	1 1/2"	1 1/2"	13 3/8"	13 1/8"	5 7/8"	22	21.5

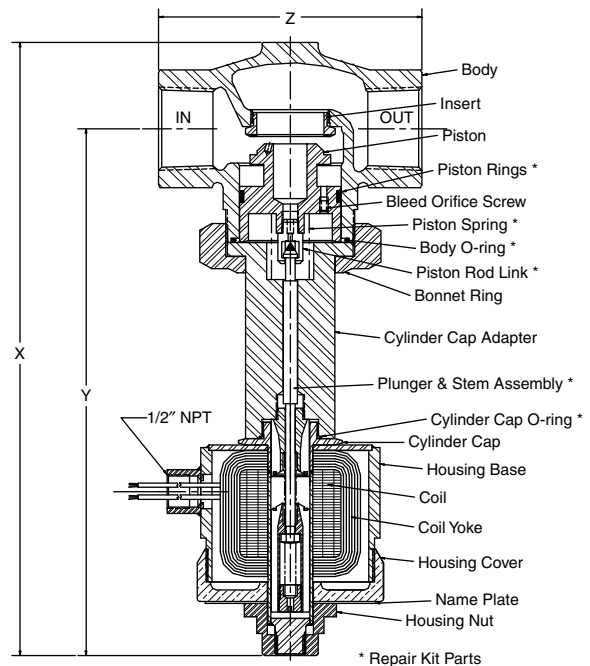

Normally open 1 1/2" 42861 valve, shown with a NEMA 7 explosion-proof coil housing and a AC coil

### 40000 Series Normally Open

CATALOG NUM. PREFIX	PIPE SIZE	MAIN SEAT ORIFICE	X	Y	Z	SHIPPING WEIGHT (lbs)	Cv
42800	1/4"	3/8"	11 1/2"	10 9/16"	3"	14	1.1
42810	3/8"	1/2"	11 1/2"	10 9/16"	3"	14	2.5
42820	1/2"	3/4"	12 5/16"	11 1/8"	4 3/8"	17	5.1
42830	3/4"	3/4"	12 5/16"	11 1/8"	4 3/8"	17	7.3
42840	1"	1"	13 3/8"	11 3/8"	5 1/4"	23	12.5

# 40000 Series

## How to Order

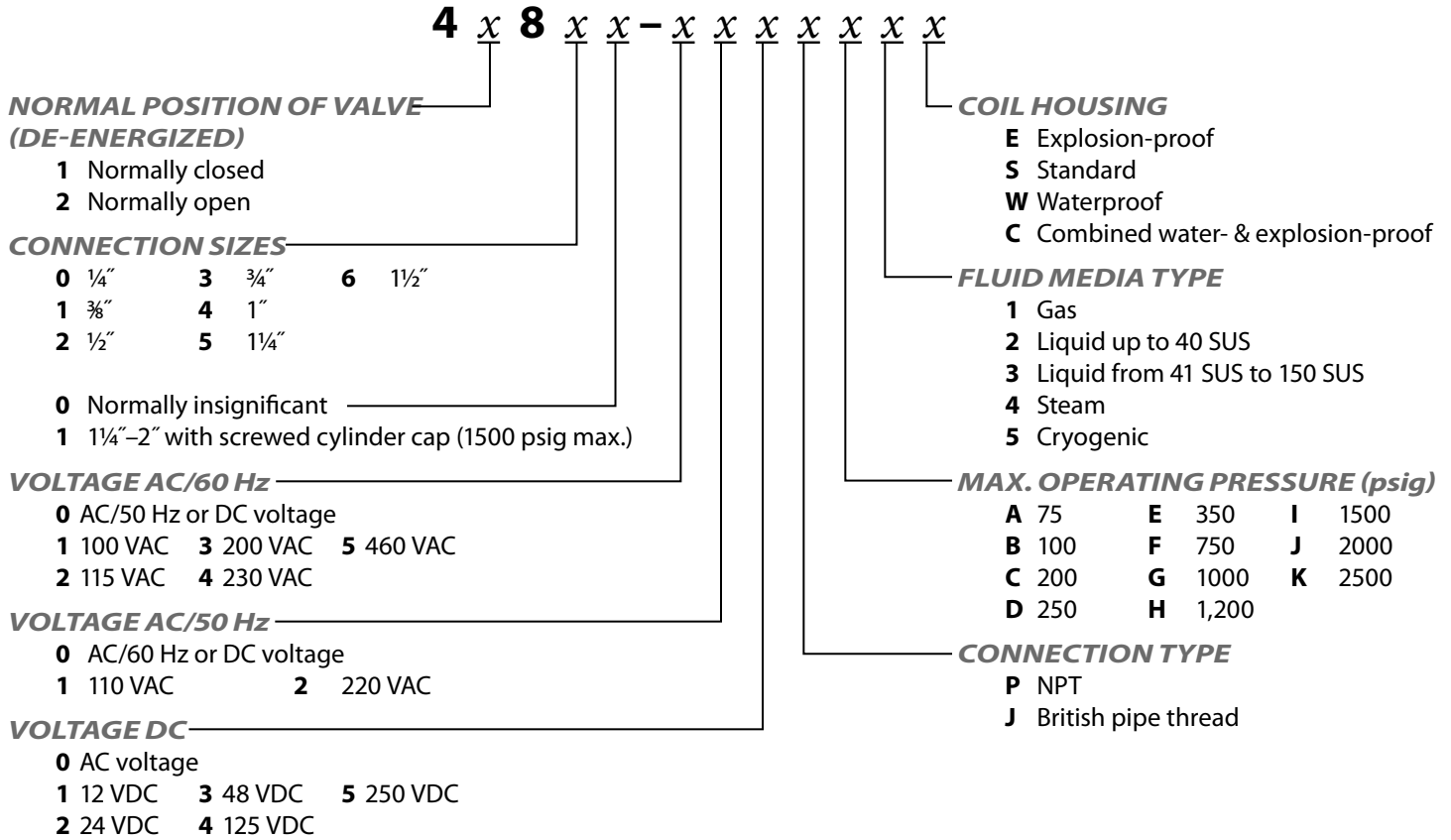

# ATKOMATIC

## 50000 Series

Stainless Steel, Direct Lift, Pressure 0 to 3000 psig (207 bar), High Temperature  
High Pressure Valve Configurable for Variety of Fluid Applications



### Features

- Designed for high temperature fluids, maximum nominal temperature rating of 750° F (399° C)
- Direct lift valve
- Barstock construction
- Mounted with coil oriented down to minimize convection heating of coil from hot media
- Flow orifices of  $\frac{1}{16}$ ",  $\frac{3}{32}$ ",  $\frac{1}{8}$ ", and  $\frac{3}{16}$ "
- Cv from 0.093 to 0.72
- Available with NPT pipe ports or welded pipe stubs as "standard" catalog items
- Normally closed and normally open versions available
- Available in pipe size from  $\frac{1}{8}$ " through 1" NPT or  $\frac{1}{8}$ " through 1" tube stubs
- Pressures up to 3000 psig (207 bar)
- Stainless steel construction on all pressure containing parts: 316 for machined parts and CF8M for cast parts.
- Plunger material is 416 stainless that is treated for increased corrosion resistance
- Will handle fluids with viscosity up to 150 SUS
- Suitable for use with wide variety of fluid including: air, gasses, liquids, hydraulic fluids, steam, cryogenic fluids, and corrosive fluids
- Stellite® seat (cobalt alloy for wear and corrosion resistance)
- Extended stem to reduce heat transfer from fluid to coil (two lengths available depending on fluid temperature)
- Class H coils are standard

### Circle Seal Controls

2301 Wardlow Circle • P.O. Box 3300 • Corona, CA 92880

Phone (951) 270-6200 Fax (951) 270-6201

www.circlesealcontrols.com • am\_sales@circlesealcontrols.com • ind\_sales@circlesealcontrols.com

atkomatic solenoid

# 50000 Series

## Operational Pressures (No minimum pressure differential)

Normally closed, extended stem, 50800–50850

ORIFICE SIZE	GASES		LIQUIDS TO 40 SUS		LIQUIDS OVER 40 SUS	
	AC	DC	AC	DC	AC	DC
1/16	2500	2500	2500	2500	2500	2500
3/32	2500	2500	2000	2000	2000	2000
1/8	1,200	1,200	900	900	900	900
3/16	500	500	350	350	350	350

Normally closed, short stem, 50900–50950

ORIFICE SIZE	GASES		LIQUIDS TO 40 SUS		LIQUIDS OVER 40 SUS	
	AC	DC	AC	DC	AC	DC
1/16	3000	3000	3000	3000	3000	3000
3/32	3000	3000	2500	2500	2500	2500
1/8	1,200	1,200	1000	1000	1000	1000
3/16	600	600	450	450	450	450

Normally open, extended stem, 50801–50851

ORIFICE SIZE	GASES		LIQUIDS TO 40 SUS		LIQUIDS OVER 40 SUS	
	AC	DC	AC	DC	AC	DC
1/16	2500	2500	2000	2000	2000	2000
3/32	1,200	1,200	1000	1000	1000	1000
1/8	400	400	350	350	350	350
3/16	250	250	150	150	150	150

Normally open, short stem, 50901–50951

ORIFICE SIZE	GASES		LIQUIDS TO 40 SUS		LIQUIDS OVER 40 SUS	
	AC	DC	AC	DC	AC	DC
1/16	3000	3000	3000	3000	3000	3000
3/32	1,600	1,600	1,200	1,200	1,200	1,200
1/8	400	400	350	350	350	350
3/16	250	250	150	150	150	150

NOTE: Normally open valves are rated for intermittent duty only on 50000 Series valves.

NOTE: Normally open 50000 Series valves are not available with 50 Hz coils for operational pressures above 1500 psi.

## Dimensions and Shipping Weights

### 50800 Series Normally Closed

(extended stem for fluid temperatures of 500° F to 750° F)

CATALOG NUM.	PIPE SIZE	X	Y	Z	SHIPPING WEIGHT (lbs)
50800	1/8"	10"	8 1/8"	4 1/16"	14
50810	1/4"	10"	8 1/8"	4 1/16"	14
50820	3/8"	10"	8 1/8"	4 1/16"	14
50830	1/2"	10"	8 1/8"	4 1/16"	14
50840	3/4"	10"	8 1/8"	4 1/16"	14
50850	1"	10"	8 1/8"	4 1/16"	14

### 50900 Series Normally Closed

(standard stem for fluid temperatures up to 500° F)

CATALOG NUM.	PIPE SIZE	X	Y	Z	SHIPPING WEIGHT (lbs)
50900	1/8"	7 1/2"	5 3/4"	4 1/16"	10
50910	1/4"	7 1/2"	5 3/4"	4 1/16"	10
50920	3/8"	7 1/2"	5 3/4"	4 1/16"	10
50930	1/2"	7 1/2"	5 3/4"	4 1/16"	10
50940	3/4"	7 1/2"	5 3/4"	4 1/16"	10
50950	1"	7 1/2"	5 3/4"	4 1/16"	10

### 50901 Series Normally Open

(standard stem for fluid temperatures up to 500° F)

CATALOG NUM.	PIPE SIZE	X	Y	Z	SHIPPING WEIGHT (lbs)
50901	1/8"	8 5/8"	6 7/8"	4 1/16"	12
50911	1/4"	8 5/8"	6 7/8"	4 1/16"	12
50921	3/8"	8 5/8"	6 7/8"	4 1/16"	12
50931	1/2"	8 5/8"	6 7/8"	4 1/16"	12
50941	3/4"	8 5/8"	6 7/8"	4 1/16"	12
50951	1"	8 5/8"	6 7/8"	4 1/16"	12

### Cv Flow Factors

ORIFICE SIZE	Cv
1/16	0.093
3/32	0.22
1/8	0.44
3/16	0.72

### 50801 Series Normally Open

(extended stem for fluid temperatures of 500° F to 750° F)

CATALOG NUM.	PIPE SIZE	X	Y	Z	SHIPPING WEIGHT (lbs)
50801	1/8"	11 1/8"	9 1/4"	4 1/16"	16
50811	1/4"	11 1/8"	9 1/4"	4 1/16"	16
50821	3/8"	11 1/8"	9 1/4"	4 1/16"	16
50831	1/2"	11 1/8"	9 1/4"	4 1/16"	16
50841	3/4"	11 1/8"	9 1/4"	4 1/16"	16
50851	1"	11 1/8"	9 1/4"	4 1/16"	16

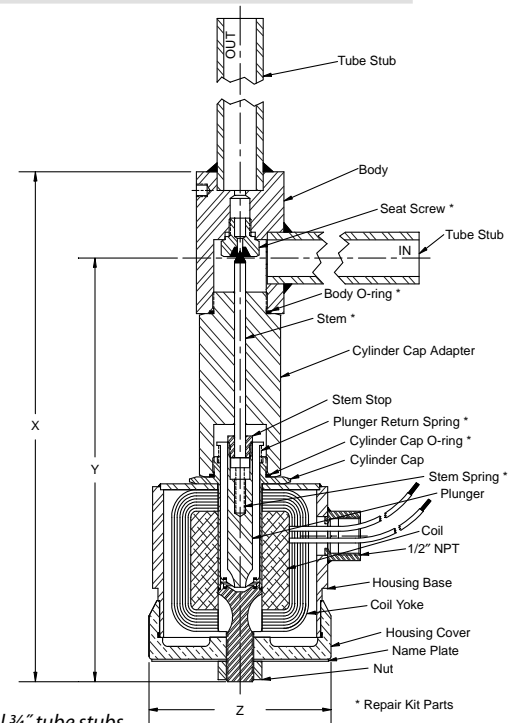

50840 valve, shown with optional 3/4" tube stubs

\* Repair Kit Parts

# 50000 Series

## How to Order

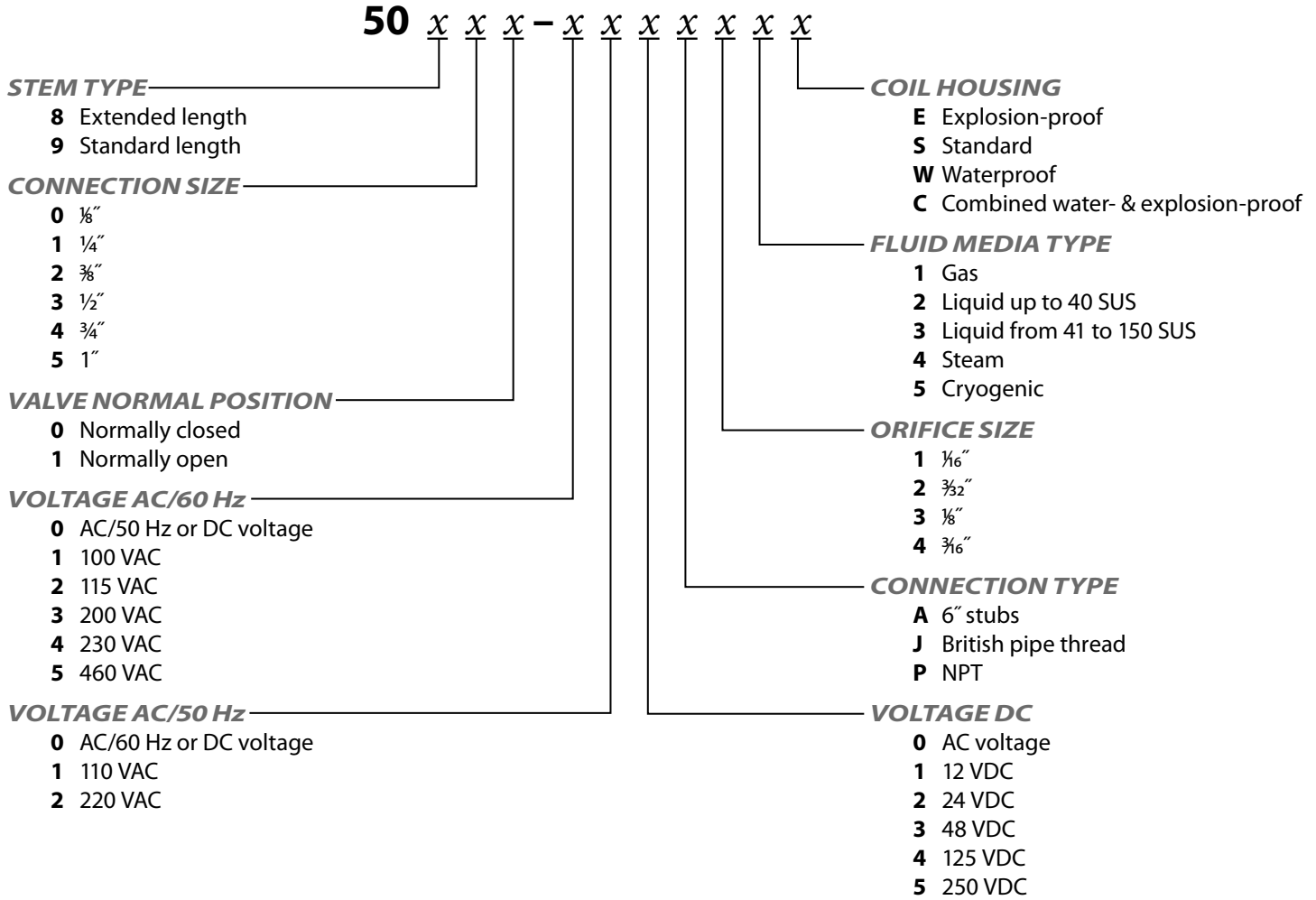

# Catalog Options

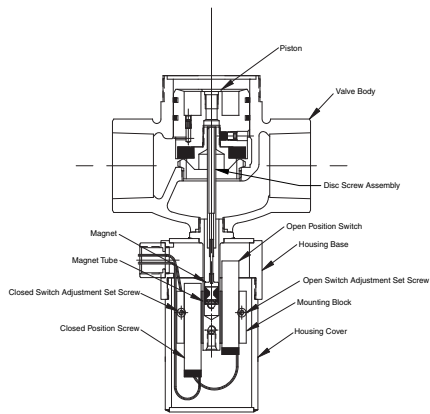

Valve position indicator option, shown with NEMA 7 explosion-proof housing

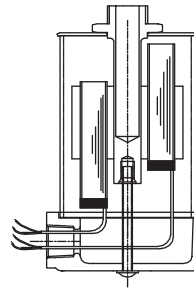

Valve position indicator option, shown with NEMA 1 standard housing

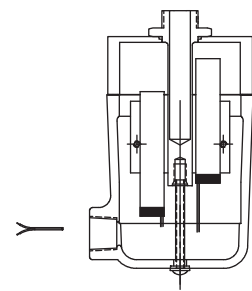

Valve position indicator option, shown with NEMA 4 waterproof housing

## Position indicator switches

This consists of a pair of reed switches that are mounted adjacent to a tube on the bottom of the valve. Inside of this tube is a magnet, which is physically attached to the piston so that it travels up and down with the piston motion. The reed switches are positioned such that when the valve is closed one switch is actuated closed by the magnet and the other switch is open. When the valve is fully open the other switch is actuated closed. It is not unusual for these switches to require some adjustments in position after final valve installation. There are set screws (one per switch) in the mounting block that can be loosened to adjust the switches position. The reed switches are a single pole, single throw configuration. Their maximum switching current is 0.7 amp for DC and 1.0 amp for AC. The maximum switching voltage is 150 volts on AC and 200 volts on DC. The switch contact rating is 70 watts on AC service and 50 watts on DC. The range of allowable fluid temperatures is reduced to a range from  $-320^{\circ}\text{F}$  to  $+450^{\circ}\text{F}$  ( $-196^{\circ}\text{C}$  to  $+232^{\circ}\text{C}$ ) when the position indicator option is installed on a valve. Typically position indicator switches are only ordered on semi-direct lift valves. It is possible to place them on pilot operated valves, but this is not generally recommended. This is because the piston position is dependent on the flow rate through the pilot operated valve. Since the magnet that actuates the switches is connected to the piston, variations in flow rate will cause the position switches to open or close. Additionally, final setting of the switches (which typically must be done after installation in the field) requires either full system flow through the valve or disassembly of the pilot operated valve and manual movement of the piston. The position indicator switch option is not available on direct lift valves.

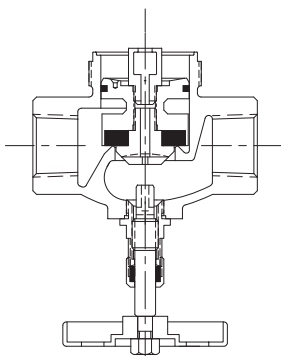

Manual opening device option

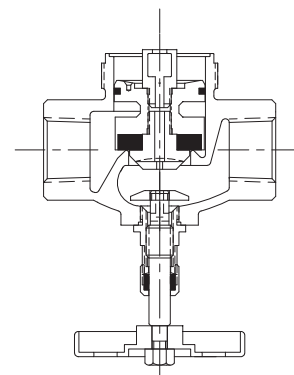

Manual throttling device option

## Manual opening

This provides a method for manually opening the valve typically for use when power failures occur. It consists of a hand wheel and rising stem attached to the bottom of the valve body. Turning the hand wheel causes the stem to mechanically push the piston open. This option requires the use of an anodized aluminum piston on models 31580 & 31590 which will affect compatibility with some fluids.

## Manual throttling

This provides a method of restricting the flow through a valve by reducing the area of the main valve orifice. It is physically similar to the manual opening device except instead of pushing the piston open, the stem pushes a baffle toward the main flow orifice under the piston. Quantitative metering of the flow is not a feature unless a separate instrument is used to measure the flow rate. This option requires the use of an anodized aluminum piston on models 31580 & 31590 which will affect compatibility with some fluids.

These options are coded into the standard catalog model number.



# Project Valve (Special, non-catalog) Options

This list of options includes some of the more commonly requested modifications to the standard catalog valves. Custom designs for specific applications are available for all the valve series. These can be requested from Circle Seal distributors or the Sales Department at Circle Seal. A complete list of stocking distributors for ATKOMATIC and other Circle Seal products is on the Internet at <http://www.circle-seal.com>.

- Flanges, pipe stubs, couplings, etc.: These are available in a variety of pressure ratings (Class 150, 300, 600, etc.) materials (stainless, carbon steel, etc.), and joining methods (butt welds, screwed and seal welded, socket welded, etc.). Special connections and installation of customer-furnished fittings is also available. Flange types available include raised face, flat face, slip-on, socket weld, weld neck, etc.
- Clad plunger for use with extremely corrosive fluids: A clad plunger consists of a slug of core iron which is encased in 316 stainless steel such that the magnetic material is separated from, and only the 316 stainless steel is in contact with, the fluid media. This option reduces operating pressure by 50% and is available on the 1000, 2000, 8000, 15800, and 16000 Series.
- Special sealing materials such as Kalrez®.
- Reduced internal leakage (frequently specified on 40000 and 50000 Series metal to metal seats accomplished by lapping seats).
- Stainless steel housings. These can meet NEMA 4X and Class I Div I Group B requirements.
- Check valve feature in piston assembly which allows full flow in the reverse direction: This consists of a small check valve mounted in the piston under the pilot orifice. There is no effect on normal valve operation, but the check valve closes off the pilot orifice when the valve is exposed to a reverse pressure differential. When this occurs the cavity above the piston is prevented from being pressurized by the downstream fluid. This allows the piston to be pushed fully open allowing free flow in the reverse direction. This option is not necessary on direct lift valves (they flow freely in the reverse direction) and is available on the following fully ported valve series: 500, 4000, 5000, 6000, 8000, 15400, 15800, 30400, 30800, and 40000. See the section on directional flow in the "Installation and General Information" section on pages 88–89.
- Fatigue resistant plunger assembly for high cycle applications: This consists of a sleeve that is brazed to the stem assembly replacing the threaded stem/nut connection.
- Nickel plating internal and/or external parts on bronze valves.
- Epoxy potted coil housings for under water installation.
- Carbon piston rings and/or metal o-rings where PTFE material is not suitable (some radioactive environments).
- Extra length coil leads and/or ground wires for coil housings.
- Special threaded connections such as AND, MS, or SAE. Not all sizes available.

These and other non-catalog options cannot be coded into standard catalog model numbers. A project valve number is assigned by the Circle Seal factory to each valve having these or other special options. These project numbers consist of the catalog valve number prefix followed by a sequentially assigned dash number. An example project number is 31840–1529 which is a 1" stainless steel 31840 valve that has been modified to meet a specific customer requirement. The factory maintains a database of all previously built project or special valves produced. Consult the Sales Department at (951) 270-6200 for application information, numbering, pricing, and deliveries of all new and existing ATKOMATIC project valves.

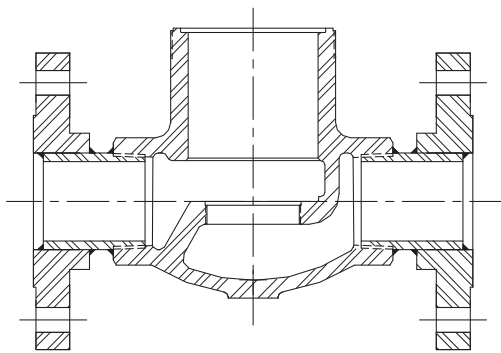

Example of coupling connection option

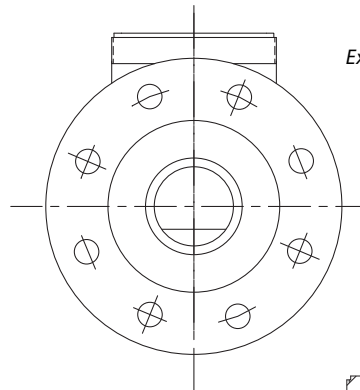

Example of flange connection option;  
raised face slip on flanges shown

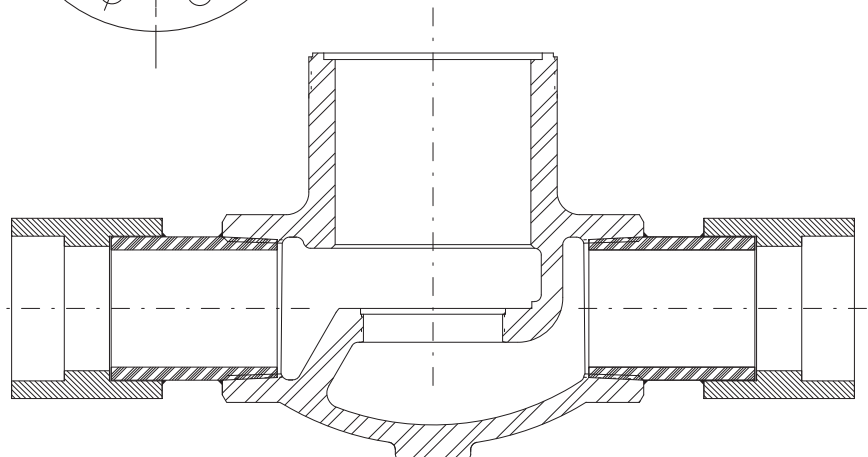

# **CIRCOR**

INSTRUMENTATION TECHNOLOGIES



**CIRCOR Instrumentation Technologies (CIT) is the logical choice for fluid control solutions. We provide the lowest cost of ownership, offering the best in class reliability and availability of our products. We have global coverage, delivering value in the form of local, flexible service to meet our customer's needs. CIT is a product group specializing in instrumentation with orifice sizes typically up to 2".**

**Our corporate head office and ISO 9001:2000 registered  
manufacturing facilities are located at  
405 Centura Court  
Spartanburg, SC, USA, 29303  
Tel +1-864-574-7966  
Fax +1-864-587-5608  
[www.hoke.com](http://www.hoke.com)  
[www.circortechnologies.com](http://www.circortechnologies.com)**

**Proudly Distributed By:**

