

INSTRUCTION MANUAL

PRESSURE-AND LEVEL TRANSMITTER

WARNING

Read this manual before working with the product. For personal and system safety, and for optimal product performance. Make sure you thoroughly understand the contents before installing, using or maintaining the SERIES 8000-VALVE-RANGE.

SERIES 8000-VALVE-RANGE



Manufactured by:

 **KLAY-INSTRUMENTS**
www.klay-instruments.com

Nijverheidsweg 5
P.O. Box 13
Tel: +31-521-591550
Fax: +31-521-592046

7991 CZ DWINGELOO
7990 AA DWINGELOO
The Netherlands
E-mail: info@klay.nl

CONTENTS

SECTION	PAGE	SECTION	PAGE
1	Description	2/6	
1.1	Dimension Drawing	2/6	
1.2	Before welding	2/6	
2	INSTALLING TRANSMITTER	3/6	
3	Mounting position effect	4/6	
3.1	Calibration	4/6	
3.2	Barometric reference	4/6	
4	Wiring	5/6	
4.1	Power supply / External Load	5/6	
4.2	Local indicator	5/6	
4.3	Traceability year of manufacturing	5/6	
4.5	CE-rules	5/6	
5	Precautions and Warnings	6/6	

1. DESCRIPTION:

De Series 8000-VALVE-RANGE is a **unique** combination of the series 8000 and ball Valve. The Series 8000-VALVE-RANGE is specially designed for the pulp- and paper industry or similar, where clogging is a problem. The very compact construction of the series 8000-VALVE-RANGE permits flush installation with the tank- or pipe wall. The transmitter part can be removed without shutting down the process (for example: during cleaning or maintaining activities). The diaphragm (21) is flush with the tank/pipe when the transmitter is pushed through the valve and locked in its measuring position. All wetted parts are made of SS 316 (AISI).

1.1 DIMENSIONAL DRAWING:

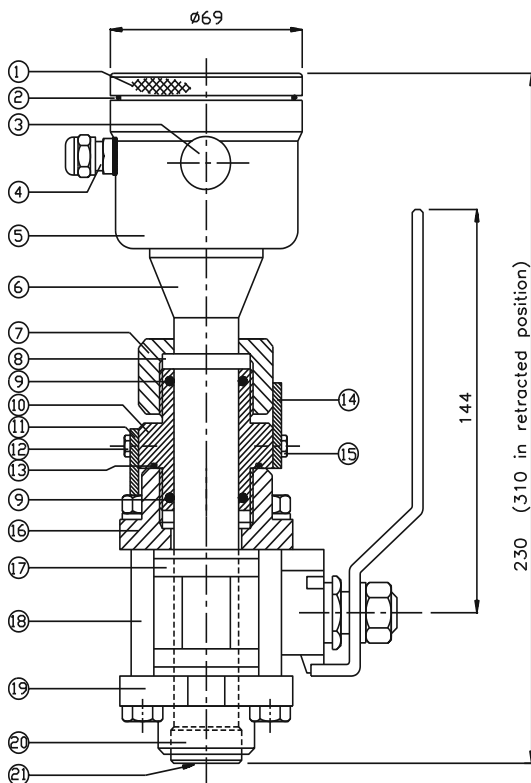

PARTS DESCRIPTION (1")

	PARTS DESCRIPTION (1")	MATERIAL
1.	Cover	SS 304
2.	O-Ring	EPDM
3.	Venting	
4.	PG9 Cable gland	
5.	Electronic Housing	SS 304
6.	Extension	SS 316
7.	Hexagon, nut SW 41	SS 304
8.	Stop	SS 316
9.	O-Ring (2x)	VITON
10.	Nipple, SW 41 (1" BSP M 2x)	SS 316
11.	Safety lock	SS 304
12.	M4 Bolt (2x)	
13.	O-Ring	VITON
14.	Safety lock	SS 304
15.	M4 Bolt(2x)	
16.	Threaded valve joint(1"BSP F)	SS 316
17.	Valve body	SS 316
18.	M8 Bolt (4x)	SS 316
19.	Weld spud (Ø 33,4 mm)	SS 316
20.	Foot with diaphragm	SS 316
21.	Diaphragm	SS 316

PARTS DESCRIPTION (1 1/2")

	PARTS DESCRIPTION (1 1/2")	MATERIAL
7.	Hexagon nut, SW 60	SS 304
10.	Nipple, SW 57 (1 1/2" BSP M 2x)	SS 316
16.	Threaded valve joint (1 1/2" BSP F)	SS 316
18.	M 10 Valve bolt (4x)	SS 316
19.	Welded spud (outside Ø 48,5 mm)	SS 316



For welding and installing the 8000-VALVE-RANGE read the next page (3/6) very carefully and follow the instructions. BEFORE OPENING THE VALVE, MAKE SURE THAT THE TRANSMITTER IS LOCKED.

1.2 BEFORE WELDING:

1. Unlock the safety lock (14).
2. Unscrew nut (7)
3. Retract transmitter until it does not want any further
4. Unlock the safety lock(11).
5. Unscrew nut (10) from threaded valve joint (16).
6. Retract transmitter from valve
7. Protect diaphragm (21) very carefully

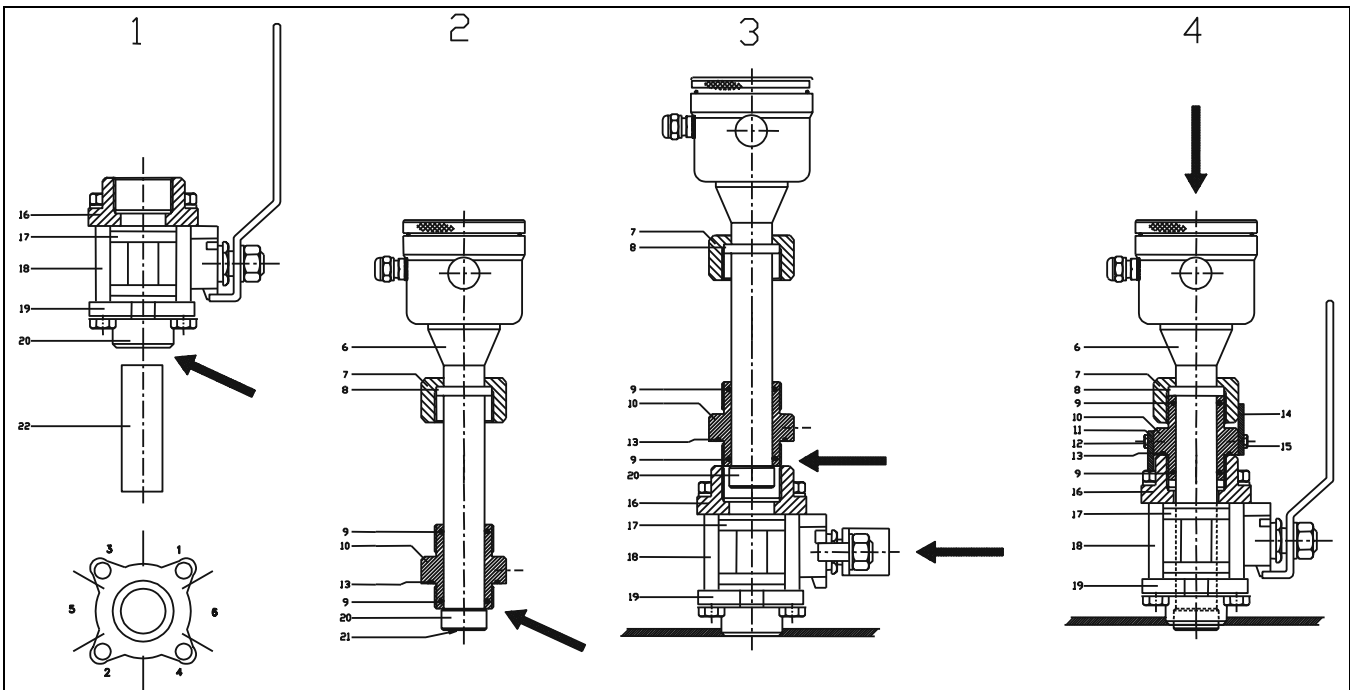

Warning:

Improper installation may result in weld spud distortion

A. Installation weld on nipple (figure 1):

1. Remove the weld spud (19) from the valve by unscrewing the four bolts(18).
2. Cut a hole in the process vessel/pipe to accept the weld spud. The hole should produce a tight fit when coupled with the weld spud.
3. Prepare the vessel hole beveling the edge to accept filler material.
4. Position the weld spud in the vessel hole and tack six places. The weld sequence is shown in figure 1.

Warning

Excessive heat will distort the weld spud (19). Weld in sections as shown in Figure 1. allow adequate cooling between passes. To reduce the chances of distortion to the weld spud, use a heat sink (22).

B. Installation Valve

1. Mount valve on the weld spud by using the auxiliary tool to ensure the parts are in-line. Use silicone grease.
2. Tighten the valve bolts (18) (4x)
3. Remove the auxiliary tool and make sure the valve and be closed and opened easily
4. Make sure valve is **CLOSED**.

Warning: DO NOT DAMAGE THE DIAPHRAGM.

C. Installation transmitter (figure 2)

1. Remove the nipple (10) to the bottom of the transmitter part as shown in figure 2. Use silicone oil or grease.
2. Make sure the O-ring (13) is properly located.

D. Figure 3

1. Make sure to correctly locate the O-ring (13) into the nipple.
2. Position the transmitter into the threaded valve joint and begin engaging the threads. The transmitter can be rotated prior to seating enabling the user to optimize access to calibration adjustments, cable entry and local indicator.
3. Tighten the nipple (10).t.
4. Lock the nipple (10) to the threaded valve joint (16) by means of the safety lock (11) and two M4 bolts(12).
5. Valve must be opened (90°) **VERY** slowly.

E. Figure 4

1. Transmitter must be pushed through valve until hexagon nut (7) reaches the nipple (10).
2. Begin engaging the threads until stop (8) reaches nipple (10).
3. Tighten hexagon nut (7).
4. Lock the nut (7) to the nipple (10) by means of the safety lock (14) and two M4 bolts (15)

2 **INSTALLING TRANSMITTER**

For welding and installing the Series 8000-VALVE-RANGE the instructions on the previous page (3/6) must be followed exactly. This is extremely important to ensure a good working of the system.

WARNING: *BEFORE OPENING THE VALVE, MAKE SURE THE TRANSMITTER IS LOCKED. BE SURE THE VALVE IS CLOSED WHEN HE TRANSMITTER IS RETRACTED FROM VALVE. THIS IS EXTREMELY IMPORTANT OTHERWISE THE TRANSMITTER WILL BE PUSHED OUT OF THE PROCESS.*

3 **MOUNTING POSITION / EFFECT:**

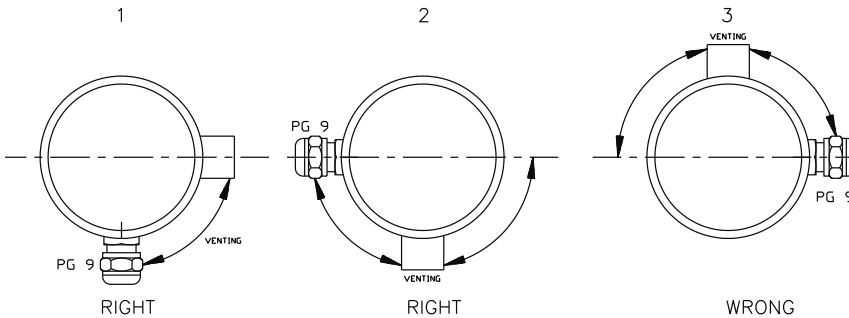

When the transmitter is mounted horizontal, the venting **MUST** be pointed horizontal to downwards. See figure left.

1=Right (=Preferred position)
2=Right

All other mounting positions are **NOT ALLOWED.**

3= Wrong

MOUNTING POSITION / EFFECT:

The transmitters are calibrated in horizontal position.

If the transmitter is mounted vertical (up or down), there will be a zero shift.

If the transmitter is mounted up there is a zero shift (<4mA). If the transmitter is mounted down a zero there is a zero shift (> 4 mA). After installation of the transmitter the zero must be set at 4mA with the zero potentiometer. **DO NOT** change the span.

3.1 **CALIBRATION:**

All transmitters are fully calibrated at the factory, to conditions stipulated in users order. When the buyer has not requested calibration, the transmitter will be calibrated at the lowest span. For wiring connection see next page.

The calibration sequence is as follows:

1. The output of the transmitter must be set at 4 mA (Zero potentiometer).
2. Air pressure in accordance with the process pressure must be put on the test nipple.
3. The output of the transmitter must be set at 20mA (Span-potentiometer).
4. Remove the air pressure.
5. Check if the output of the transmitter is 4 mA (otherwise repeat steps 1 till 4).
6. Install transmitter (see above).
7. The output must be set at 4 mA (dependable of mounting position)

3.2 **BAROMETRIC REFERENCE:**

The series 8000 is in basic a so-called "relative transmitter" which means that barometric changes will not affect the zero (4 mA). The venting is placed in the cover of the electronic housing and is the barometric reference to atmospheric pressure. The venting must be kept clean.

4 WIRING:

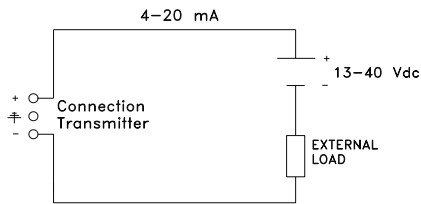

TERMINAL BOARD

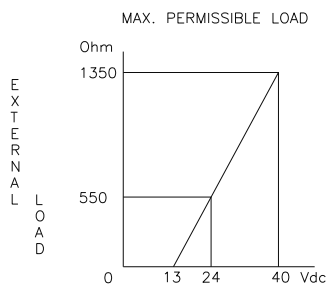
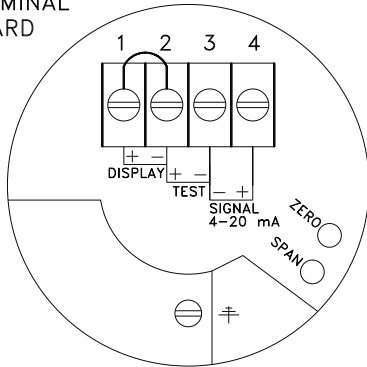

The connector, and zero / span potentiometers are under the cover. Test nipples for calibration of the SERIES 8000 and SERIES 8000-SAN are available on request.

External loads must be placed in the negative side of the 2-wire loop.

The figure left shows the wiring connection of the transmitter. The 2-wires must be connected to connectors 3 (-) and 4 (+) of the terminal board.

The transmitter must always be connected to earth.

The transmitter must be connected with standard two-wire shielded cable. **DO NOT** run signal wiring in open trays with power wiring, or near "heavy" electrical equipment (E.g. Frequency controllers or heavy pumps). Shielding must always be connected at the side of the power supply. In case the mounting position is already connected to ground (e.g. via the tank or pipe line) do NOT connect the instrument to ground. **Please ensure that the instrument is not connected to ground twice to prevent the occurrence of an 'earth loop'.**

4.1 EXTERNAL LOAD:

The maximum permissible load (Ri max.) in case of 24 Vdc is 550 Ω (Ohm).

By increasing the power supply, the external load can be increased to 1150 Ohm / 36 Vdc. (see figure left).

$$R_{I \text{ max.}} = \frac{\text{Power Supply} - 13 \text{ Vdc (min. power supply)}}{20 \text{ mA}}$$

4.2 DIGITAL LOCAL INDICATOR:

The local indicator displays a digital value that is proportional to the pressure measured by the transmitter. The full scale point may be set to any value between 0000 and 1999. The local indicator can be mounted afterwards. Remove the bridge which is placed between connector (1) and (2). Connect the red (+) wire to (1) and the black (-) wire to (2). When using a local indicator the minimum power supply must be **15.5 Vdc**.

4.3 TRACEABILITY YEAR OF MANUFACTURING:

The year of manufacturing of the transmitter can be traced as follows: take the first two numbers from the serial number that is engraved in the transmitter and add 1908.

For example: if the serial number is 10509426. The year of manufacturing is 1908 + 105 = 2013.

For older transmitters, for example with serial number 9302123, the first **two** numbers must be add with 1908

4.4 CE / EMC - Rules:

All Klay transmitters are manufactured in accordance with the RFI / EMC directives and comply with the CE standard. All transmitters are fitted with RFI filters, which provide optimum, trouble-free operation. Our products are in conformity with EMC-Directive 2014/30/EU based on test results using harmonized standards.

PRECAUTIONS and WARNINGS:

We herewith give a list of some precautions and warnings concerning the application and installation of the electronic pressure – and level transmitters, SERIES 8000-VALVE-RANGE

- * Check if the specifications of the transmitter meet the needs of the process conditions.
- * **BE SURE THE VALVE IS CLOSED WHEN THE TRANSMITTER IS RETRACTED FROM THE VALVE**
- * When the SERIES 8000–VALVE-RANGE is used as a level transmitter, be aware of the place where the transmitter is mounted. Here are some advises:
 1. **DO NOT** mount a level transmitter in- or near filling or discharging pipes.
 2. In case of automatic cleaning systems or hand cleaning: never point the water jets on the diaphragm, take necessary steps to avoid this. Guarantee will not be granted.
- * When the SERIE 8000–VALVE-RANGE is used as a pressure transmitter, be aware of the following points:
 1. Rapid closing valves in combination with high flow velocity will cause water hammer(spikes) and can destroy the transmitter. **DO NOT** mount a transmitter near such valves, always a few pipe bends away up or down stream (avoid suction).
 2. Install a pressure transmitter a few pipe bends away from pumps, as well on the suction or pressure side of the pump.
- * **WELDING ADVISEMENT:**
When using the SERIES 8000–VALVE-RANGE the welding advisements on page 3 must be followed exactly. This is very important to prevent distortion of the weld spud.
- * The diaphragm of the SERIES 8000–VALVE-RANGE transmitter is protected with a special protection cap. Protect the diaphragm until installation takes place, to prevent damaging of the diaphragm.
- * As soon as the wiring is brought inside through the PG9 cable gland and connected to the terminal board, make sure the cable gland is tightly fixed, so that moisture cannot enter into the electronic housing.
- * **NEVER unscrew the venting (3), it is especially designed to prevent moisture from entering into the electronic housing. If the ambient conditions are very wet, we advise to use a venting through the cable. A special vented cable can be delivered on request.**
- * Avoid high pressure water-jets pointed at the venting.
- * The cover must be fully engaged, so that moisture cannot ingress into the electronic housing.
- * **WARRANTY: The warranty is 1 year from delivery date. Klay Instruments B.V. does not accept liability for consequential damage of any kind due to use or misuse of the SERIES 8000–VALVE-RANGE. Warranty will be given, to be decided by the manufacturer. Transmitter must be shipped prepaid to the factory on manufacturer's authorization.**
- * **NOTE: Klay Instruments B.V. reserves the right to change its specifications at any time, without notice. Klay Instruments B.V. is not an expert in the customer's process (technical field) and therefore does not warrant the suitability of its product for the application selected by the customer.**

Manufactured by:

 **KLAY-INSTRUMENTS**

www.klay-instruments.com

Nijverheidsweg 5
P.O. Box 13
Tel: +31-521-591550
Fax: +31 -521-592046

7991 CZ DWINGELOO
7990 AA DWINGELOO
The Netherlands
E-mail: info@klay.nl