



**INSTRUCTION MANUAL "PROFIBUS PA"
PROFILE V3.0**

**"INTELLIGENT"
PRESSURE- AND LEVEL TRANSMITTERS**

**SERIES 2000-SAN
SERIES 2000
SERIES CER-2000**

WARNING

Read this manual before working with the product. For personal and system safety and for optimum product performance, make sure you thoroughly understand the contents before installing, using, or maintaining the Series 2000, Series 2000-SAN and the Series CER-2000. Read the precautions and warnings on page 52.



SERIES 2000



SERIES 2000-SAN



SERIES CER-2000

MANUFACTURER:
KLAY INSTRUMENTS B.V.

Nijverheidsweg 5 7991 CZ Dwingeloo
P.O. BOX 13 7990 AA Dwingeloo Netherlands
www.klay.nl

Tel: +31 521 591550
Fax: +31 521 592046
E-mail: info@klay.nl

CONTENTS

SECTION		PAGE
1	Introduction	5
1.1	Description Series 2000–SAN	5
1.2	Description Series 2000	5
1.3	Description Peramic® ‘S’ (Series CER-2000)	5
1.4	Barometric reference	5
2	Dimensional drawings	6
2.1	Dimensional drawing 2000-SAN	6
2.2	Dimensional drawing 2000	6
2.3	Dimensional drawing CER-2000	6
3	Installing transmitter	7
3.1	Installing weld-on nipple	7
3.2	Installing transmitter Series 2000-SAN	7
3.3	Installing transmitter Series 2000	7
3.4	Installing transmitter Series CER-2000	8
3.5	Mounting position	8
3.6	Mounting position effect	8
3.7	Calibration	8
3.8	Wiring	8
4	Remaining	10
4.1	Digital local indicator	10
4.2	CE-rules	10
5	Functions of push buttons	11
6	Programming points	12
7	Readout on display	12
8	Explanation menu	13
	Esc	13
	Ph.bl Physical block	13
	tr.bl Transducer block pressure transmitter	14
	tr.bl Transducer block level transmitter	16
	AI.BL Analog Input block	18
	Util Utility menu	20

9	Profibus	21
9.1	PA interface	21
9.2	Cyclic communications (DP-V0)	21
9.2.1	Setting the slave's network id	21
9.2.2	Identnumber and GSD-file	22
9.2.3	Setting the identnumber	22
9.2.4	Using GSD-files	22
9.2.4.1	Device set to manufacturer specific ID	22
9.2.4.2	Device set to profile specific ID	23
9.2.5	Construction of the cyclic data (OUT-value)	24
9.2.5.1	Encoding OUT-value	24
9.2.5.2	Encoding status byte	24
9.3	A-cyclic communication (DP-V1)	26
9.3.1	The PA-block model	26
9.3.2	Device Management	27
9.3.3	Physical block	27
9.3.4	Transducer block	30
9.3.4.1	Pressure transducer block	30
9.3.4.2	Level transducer block	35
9.3.5	Analog input block	39
9.3.6	Klay specific parameters	42
9.4	Configure a PA-SLAVE	43
9.4.1	Pressure transmitter: EXTENDED_CONFIG off	43
9.4.2	Pressure transmitter: EXTENDED_CONFIG on	44
9.4.3	Level transmitter: EXTENDED_CONFIG off	45
9.4.4	Level transmitter: EXTENDED_CONFIG on	45
.		
10	Specification	47
.		
APPENDIX A	Series 2000PA Pressure	48
APPENDIX B	Series 2000PA Level	50
APPENDIX C	TANK LINEARISATION (table)	53
APPENDIX D	Decoding IEEE754 Floating point notation	54
APPENDIX E	Profibus Certificates	55
APPENDIX F	Precautions and warnings	56

1 INTRODUCTION:

The SERIES 2000 and SERIES 2000-SAN are solid-state pressure- and level transmitters based upon a piezoresistive silicon sensor, with a very high burst pressure. The sensor element is mounted in a stainless steel foot. A very strong stainless steel "flush" diaphragm protects the sensor from the process medium. Silicone oil fills the chamber surrounding the sensor and transfers pressure from the flush mounted diaphragm to the sensor.

The Series CER-2000 are "All Stainless" pressure transmitters based on a ceramic pressure cell, with very high burst pressure. These transmitters do not have oil filling.

Pressure exerted on the sensor element creates a very small deflection of the silicon substrate and bridge network. The resulting strain in the silicon resistors causes a change in the bridge resistance that is proportional to the pressure applied. The transmitter electronics detects this change in bridge resistance and a digital value.

1.1 DESCRIPTION SERIES 2000-SAN:

The SERIES 2000-SAN are specially designed to be non-clogging and capable of being cleaned inside, therefore they have a flush mounted diaphragm so they fully meet the needs of the food, chemical and pharmaceutical industries.

Standard the wetted parts are made of SS 316 (AISI), many other materials are available. Various process connections can be delivered, such as Tri-Clamp, SMS, dairy milk couplings, flanges and very sanitary weld-on nipples \varnothing 62 and 85 mm.

1.2 DESCRIPTION SERIES 2000:

The SERIES 2000 is specially designed for the pulp- and paper industry or similar, where clogging is a problem. The very compact construction of the SERIES 2000 permits flush installation with the tank- or pipewall. Standard the wetted parts are made of SS 316 (AISI), a lot of other materials are available.

All transmitters are fully temperature compensated, which means that various process temperatures have nearly no effect on the accuracy of the output signal. When a failure occurs, the transmitter is repairable. However, for optimum accuracy the transmitter has to be send back to the factory.

1.3 DESCRIPTION PERAMIC® "S" (SERIES CER-2000):

The Series CER-2000 are pressure transmitters based on a ceramic pressure cell, which can be used for all gauge- and absolute pressure measurement on steam, liquids and gases. These transmitters do not have oil filling.

1.4 BAROMETRIC REFERENCE:

The SERIES 2000-SAN are in basic so-called "relative transmitter" which means that barometric changes will not affect the zero. The venting (4) is placed at the side of the electronic housing and is the barometric reference to atmospheric. The venting must be kept clean.

2 DIMENSIONAL DRAWINGS:

2.1 DIMENSIONAL DRAWING 2000-SAN:

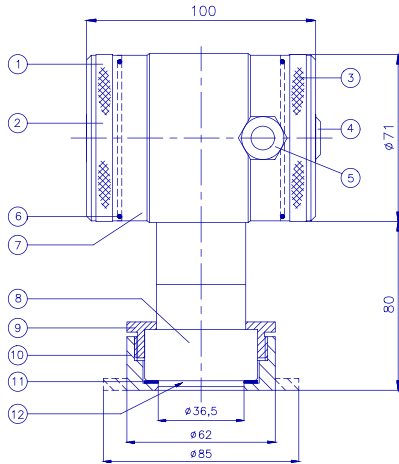

PARTS DESCRIPTION:

MATERIAL:

- | | | |
|-----|----------------------|------------|
| 1. | Cover | AISI 304 |
| 2. | Pushbutton + Display | |
| 3. | Cover with venting | AISI 304 |
| 4. | Venting | PA |
| 5. | PG9 Cable Gland | |
| 6. | O-ring (2 pcs) | EPDM |
| 7. | Electronics housing | AISI 304 |
| 8. | Foot | AISI 316 |
| 9. | Lockring | AISI 304 |
| 10. | Weld-on nipple | AISI 316 L |
| 11. | Packing | PTFE |
| 12. | Diaphragm | AISI 316 L |

2.2 DIMENSIONAL DRAWING 2000:

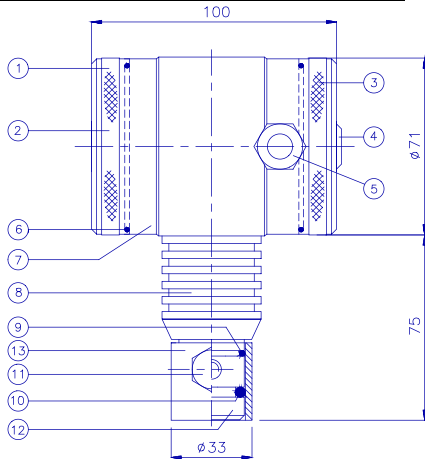

PARTS DESCRIPTION:

MATERIAL:

- | | | |
|-----|------------------------|------------|
| 1. | Cover | AISI 304 |
| 2. | Pushbutton + Display | |
| 3. | Cover with venting | AISI 304 |
| 4. | Venting | PA |
| 5. | PG9 Cable Gland | |
| 6. | O-ring (2 pcs) | EPDM |
| 7. | Electronics housing | AISI 304 |
| 8. | Foot with cooling fins | AISI 304 |
| 9. | O-ring | Viton |
| 10. | O-ring | Viton |
| 11. | M8 bolt | AISI 316 |
| 12. | Diaphragm and ring | AISI 316 |
| | Weld-on nipple | AISI 316 L |
| | Ø 33 mm | |

2.3 DIMENSIONAL DRAWING CER 2000:

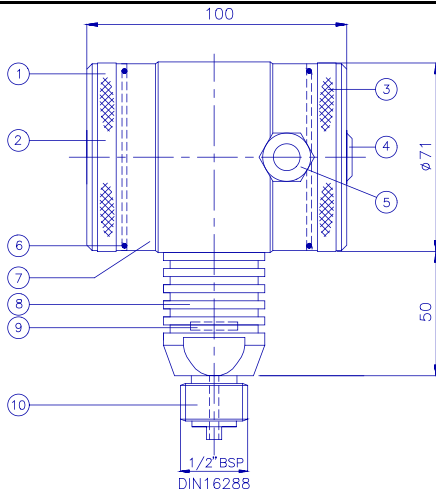

PARTS DESCRIPTION:

MATERIAL:

- | | | |
|-----|------------------------|-------------|
| 1. | Cover | AISI 304 |
| 2. | Pushbuttons + Display | |
| 3. | Cover with venting | AISI 304 |
| 4. | Venting | PA |
| 5. | PG9 Cable Gland | |
| 6. | O-ring (2 pcs) | EPDM |
| 7. | Electronics housing | AISI 304 |
| 8. | Foot with cooling fins | AISI 316 |
| 9. | Ceramic sensor | Al2O3 (96%) |
| 10. | Process connection | AISI 316 |
| | □" BSP (M) DIN | |
| | 16288 | |

Note: The ceramic sensor is sealed with an O-ring (VITON). Other O-ring materials can be applied (on request).

3 INSTALLING TRANSMITTER:

The diaphragm of the transmitter is protected with a special protection cap. Protect the diaphragm until installation takes place. * DO NOT DAMAGE THE DIAPHRAGM. *

3.1 INSTALLING WELD-ON NIPPLE:

A skilled machinist or welder should perform installation of the weld-on nipple. Weld Argon, MIG or TIG with the smallest welding pin.

1. Cut a hole in the process vessel/pipe to accept the weld-on nipple. The hole should produce a tight fit when coupled with the weld-on nipple.
2. Prepare the vessel hole by beveling the edge to accept filler material.
3. Remove the weld-on nipple from the transmitter.
4. Remove the PTFE packing of the SERIES 2000-SAN.

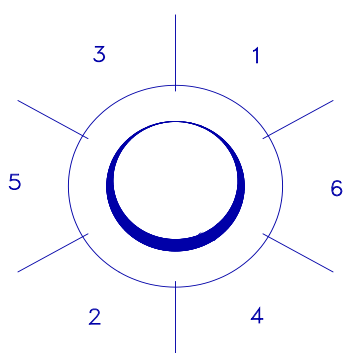

WARNING:

Improper installation may result in distortion of the weld-on nipple.

Excessive heat will distort the weld-on nipple. Weld in sections as shown in the figure left. Allow adequate cooling between passes. To reduce the chances of distortion to the weld-on nipple, use a mandrell.

(SERIES 2000-SAN Part.nr. 1019)

(SERIES 2000 Part.nr. 1016)

The position of the electronic housing (SERIES 2000) is fixed by the welding position of the weld-on nipple. Before welding, locate weld-on nipple so that the cable entry and the venting are in the right direction.

5. Position the weld-on nipple in the vessel hole and tack six places. The weld sequence is shown in the figure above.
6. Weld the weld-on nipple in place using 0,03 to 0,045 in. (0,762 to 1,143 mm) stainless rod as filler material in the beveled area. Adjust amperage for penetration.
7. Remove mandrel after the welding operation.

3.2 INSTALLING TRANSMITTER SERIES 2000-SAN:

1. Improper installation at the packing can cause a process leak.
2. Make sure to correctly locate the packing within the weld-on nipple.
3. Position the transmitter into the weld-on nipple and begin engaging threads. The transmitter can be rotated prior to seating enabling the user to optimize access to calibration adjustments, cable entry, and local indicator.
4. Once Lockring (8) has been hand tightened, snug an additional turn with adjustable pliers (1/8").

3.3 INSTALLING TRANSMITTER SERIES 2000:

1. After welding, clean up edges, take care of the inside nipple wall.
2. Make sure the O-rings (10) and (11) are properly located. Improper installation at the O-ring can cause a process leak.
3. Apply silicone grease to the O-ring (10), diaphragm ring and the hole inside wall of the weld-on nipple, this prevents galvanic cell corrosion between transmitter and nipple inside.
4. Install the transmitter and fix it with the SS M8 bolt.

3.4 INSTALLING TRANSMITTER SERIES CER-2000:

The position of the electronic housing is depends on the welding position of the weld-on nipple. Before welding, locate weld-on nipple so that the cable entry and the venting are in the right direction.

DO NOT DAMAGE THE SCREW THREAD!

3.5 MOUNTING POSITION:

When the transmitter is mounted horizontally, the cable gland MUST be pointed downwards.

3.6 MOUNTING POSITION EFFECT (Series 2000 and Series 2000-SAN):

All transmitters are calibrated in horizontal position.

If the transmitter is mounted vertical (up or down), there will be a little zero shift.

If the transmitter is mounted up, there is a zero shift (e.g. 0.05 bar instead of 0.00 bar). If the transmitter is mounted down, there is a zero shift (e.g. -0.05 bar instead of 0.00 bar). After installation of the transmitter the zero must be set to 0.00 bar by using the cancel mounting position function. This will not affect the span.

3.7 CALIBRATION:

All transmitters are fully calibrated at the factory, to the conditions stipulated in users order.

When the buyer has not requested calibration, the transmitter will be calibrated at the highest span. It is advisable to re-calibrate the transmitter after shipment.

3.8 WIRING:**3.8.1 Profibus PA wire:**

Special Profibus PA wire should be used in a Profibus PA network. This cable has properties that are optimized for communication over a Profibus PA network.

Properties PA cable:

Parameter	
Cable type	Twisted pair shielded
Core	0,8 mm ² (AWG 18)
Loop resistor	44 Ω/km
Impedance @ 31.25 kHz	100 Ω ± 20%
Damping (@ 39 kHz)	3 dB / km
Asymmetric capacity	2 nF / km

3.8.2. Termination:

Both ends of a cable-trunk has to terminated by a terminator. A terminator is basically a resistor (100 Ω) and capacitor (1 μF) connected in series. To terminate the wire connect these between PA+ and PA-. If no terminators are used, it can result in bad or no data communication.

In common a terminator is integrated in the segment coupler/link. There are to possible ways to terminate the other end of the cable: first a special terminator can be used. Second (if present) an integrated terminator of a junction block can be used (in most cases it can be switched on or off).

3.8.3 Connecting the transmitter:

Under the cover (3) you will find the terminal board.

Between connector 1 and 2 a bridge is mounted. Do **not** remove this bridge (when removing the loop is cut and the transmitter will **not** work at all).

The Profibus cable must be connected as follows
PA- (blue) on 3 (-); PA+ (brown) on 4 (-)
Care must be taken to assure that the polarity of the power supply is correct, a reversal of wiring polarity will not damage the transmitter, but it will not function until the wiring is connected correctly.

The connectors 2 and 3 can be used for testing.
The signal in the loop of the transmitter can be measured or checked.

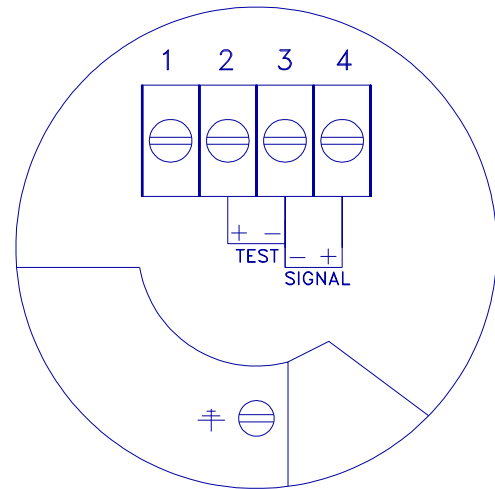

You can also use the so called M12 cable connectors. These cable-connectors are very often used in profibus networks and can be delivered on the Series 2000 PA transmitters (optionally, extra price).

3.8.4 Earthing:

The signal wiring must be shielded. **DO NOT** run signal wiring in open trays with power wiring, or near "heavy" electrical equipment (E.g.: Frequency controller or heavy pumps). In case the mounting position is already connected to earth (e.g. via the tank or pipe line) **do NOT** connect the instrument to earth. **Please ensure that the instrument is not connected to earth twice to prevent the occurrence of an 'earth loop' which can cause (communication) errors.**

If necessary the shielding should be isolated from the transmitter housing and must always be connected at the side of the power supply or at the junction box.

For further information about the installation and earthing of Profibus PA networks we refer to the following document: *Profibus Technical Guideline – Profibus PA User and Installation Guideline Version 2.2. February 2003*, distributed by PNO (Profibus Nutzer Organisation).

4. REMAINING:

4.1 DIGITAL LOCAL INDICATOR:

All transmitters from the Series 2000 are standard equipped with a digital display. In the standard execution the covers are "closed". The three push buttons and the display are behind the cover (3).

As an option an "open" cover can be delivered to achieve the display can be used as a local display in the process. The full-scale point may be set to any value between 0000 and 9999 (4 digit). (Option: "I" extra price).

4.2 CE-rules:

All our transmitters are manufactured according to the CE-rules. All transmitters are standard equipped with RFI filters. The influence on Radio Frequency Interference between 10 MHz to 10 GHz is neglect able.

5 FUNCTIONS OF PUSH BUTTONS:

The Series 2000 can be programmed easily by use of the 3 front panel pushbuttons (See picture right).

The display can show engineering units of: mH₂O, inH₂O, bar and PSI.

The functions of the three pushbuttons will be explained below.

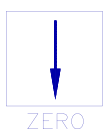
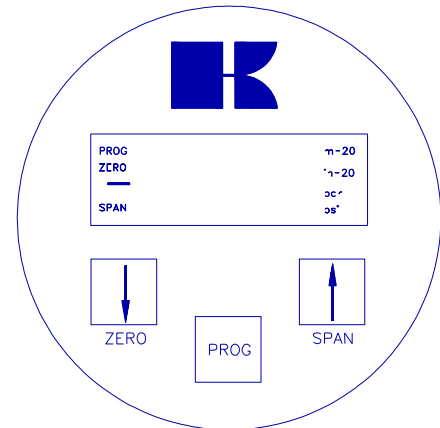

This button has 2 functions:

1. It can be directly used for adjusting the zero (zero), with or without a test pressure. When the zero must be adjusted at 0 (atmospheric pressure), the button must be held until the word "ZERO" appears on the display.
2. Also, this button must be used for stepping down in the programming menu or to decrease a value (-).



This button has 2 functions:

1. It can be directly used for adjusting the span, when using a test pressure (air). When a test pressure (e.g. 2 bar) is supplied to the transmitter, the button must be held until the word "SPAN" appears on the display. The span can also be adjusted without test pressure.
2. Also, this button must be used for stepping up in the programming or to increase a value (+).



This button has 2 functions:

1. Pushing this button, will display "ESC". This means you have entered the program menu. By pushing [PROG] again you will escape from the menu. Use the ↑ [SPAN] and ↓ [ZERO] to step through the menu.
2. This button can also be used for confirming the adjustments (enter).

For example if you want to change the sensor units in bar, the following steps must be taken:

1. Push on [PROG] till "ESC" appears on the display.
2. Push on ↑ [SPAN] 2 times to go to point "tr.bl" (transducer block).
3. Push [PROG] to confirm this.
4. Push 4 times ↑ [SPAN] to reach 4 (= sensor units).
5. Confirm this by pushing once at [PROG].
6. The actual sensor unit code is shown on the display. Push several times [↑] or [↓] until you reach the code for bar (1137).
7. Confirm by pushing [PROG].
The transmitter sensor value readout is now adjusted to "bar".

6. Programming points

The following points can be adjusted by means of the three push buttons. For an explanation of these points see page 12 to 19 of this manual.

To change one of these points you have to push on [PROG] until "ESC" appears on the display. To go to the desired menu push [↑] or [↓].

To confirm the adjustments always press [PROG].

The next pages will discuss the menu blocks.

Menu:	
ESC	
Ph.bL	Physical block
tr.bL	Transducer block (pressure / level)
Ai.bL	Analog input block
Util	Utility-menu

7. READOUT ON THE DISPLAY:

The standard built-in display can show several readout.

During configuring the transmitter the display shows all information that is needed.

When the transmitter is in the process, the display shows all information of the process pressure or temperature.

On the display the following units can be shown as text: mH2O, inH2O, bar and PSI.

PROG	mH2O
ZERO	inH2O
—	bar
SPAN	psi

The readout can also be adjusted to 'percent of range' (%).

N.B: Standard a transmitter is supplied with two "closed" covers, shielding the buttons and the display. As an option an "open" cover (IP 65) can be fitted. The display can then be used as a local process display. (Option: "I" extra price).
The full scale can be set between -9999 and 9999 (4 digit).

8. EXPLANATION MENU'S

Esc **Escape from menu :**

Ph.bl **Physical block:**

-
- 0. Escape from the Physical block menu
 - 1. IDENT_NUMBER
 - 9700: PROFILE
 - 0A2A: MANUFACTURER SPECIFIC (for pressure transmitter)
 - 0A29: MANUFACTURER SPECIFIC (for level transmitter)
 - 2. WRITE_LOCKING (write protection by communication)
 - OFF
 - ON
 - 3. FACTORY_RESET
 - 0 Escape
 - 1 (Reset to default values)
 - 2 (Reset I-parameters to default values)
 - 3 (Reset F-parameters to default values)
 - 2506 (re-start the equipment)
 - 2712 (Reset address to 126)

After confirming, the readout will automatically return to the actual readout.

tr.bL **Transducer Block (Pressure Transmitter):**

tr.bL **Transducer Block (Level Transmitter):**

In this menu several parameters of the Analog Input block (AI) can be configured.

- 0 Escape function from the analog input block menu.
- 1 CHANNEL
 - Options (Pressure Transmitter):
 - 0 = 112_{hex} (274)
PRIMARY_VALUE is input for the analog input block.
 - 1 = 11D_{hex} (285)
SECONDARY_VALUE_1 is input for the analog input block
 - 2 = 11F_{hex} (287)
SECONDARY_VALUE_2 is input for analog input block

Options (Level Transmitter):

- 0 = 108_{hex} (264)
PRIMARY_VALUE is input for the analog input block.
- 1 = 10E_{hex} (270)
SECONDARY_VALUE_1 is input for the analog input block
- 2 = 110_{hex} (272)
SECONDARY_VALUE_2 is input for analog input block

For further explanation of the parameter CHANNEL, please refer to chapter 9.3.4.1. The factory setting for CHANNEL is option 0.

2 PV_TIME

Adjustment of electronic damping. The damping can be adjusted from 0 sec. to 25 sec. The value can be entered using the [↓] and [↑] buttons. Confirm by pushing [PROG].

3 SIMULATE

This menu can be used to perform a simulation. By entering the menu the display will start blinking showing the transmitter is in simulation mode. There are two options: simulation by value and simulation by status.

Option:

- 0: Simulate by value. Entering the menu the value 0.0 will be displayed. Using the ↓ [ZERO] and ↑ [SPAN] buttons this value can be changed (-999.9 to 999.9). Pressing the [PROG] button confirms this value as input for the Analog Input block. Using ↓ [ZERO] and ↑ [SPAN], the simulation value can be changed. To accept the new value as simulation value press [PROG].
To end the simulation, press [PROG] two times (press a bit longer than before)
- 1: Simulate by status: Entering the menu the status value (decimal value) will be displayed. Using the ↓ [ZERO] and ↑ [SPAN] buttons this value can be changed (0 to 255). Pressing [PROG] button confirms this value as status input for the Analog Input block. Using ↓ [ZERO] and ↑ [SPAN] the simulation status value can be changed. To accept the new value as status value press [PROG].

To end the simulation, press [PROG] two times (hold keys a little bit longer than normally)

*) During the simulation the Analog Input block state machines will be active. For further information about the state-machines please check the Profibus PA Profile definition.

4 EXTENDED_CONFIG

Use this option for quick adjustments for simple applications.

Options:

- Off configure the transmitter (function blocks) fast and easy.
- On configure the transmitter (function blocks) by checking all parameters.

When EXTENDED_CONFIG is adjusted to OFF, all pressure or level related

parameters are scaled to a 1 to 1 base. This means: when, for example, SCALE_IN_LOW is changed in the transducer block, the IN_SCALE and OUT_SCALE parameters will be adjusted to the same value. This results in a 1 to 1 scale function between the transducer block and the analog input block. The OUT-value (in the analog input block) will get the same unit as the sensor value in the transducer block.

When a scaling function (not equal to a 1 to 1 base) is needed, for example conversion to a value which can be used by a PLC, please change EXTENDED_CONFIG to ON.

In this menu some parameters of the level transducer block can be adjusted.

- 0 Escape function from the transducer block menu
- 1 CAL_POINT_LOW
 - Zero adjustment (Zero). Use the ↓ [ZERO] and ↑ [SPAN] push buttons to adjust. Confirm with [PROG].
 - 2 CAL_POINT_HIGH
 - Span adjustment (Span). Use the ↓ [ZERO] and ↑ [SPAN] push button. The value can be adjusted between minimum span en high sensor limit. Confirm with [PROG].
- 3 CANCEL_MOUNTING_EFFECT
 - Options:
 - Esc: Escape from menu without changes.
 - r.Set: When using this option the original factory setting will be valid
 - Set: Perform cancel mounting position effect function

Confirm your selection with [PROG].
- 4 SENSOR_UNIT / SEC_VAL_2_UNIT
Change the sensor units.

UNIT TABLE:

	CODE	UNIT	
1	1521	mH2O (mWC)	*
2	1149	mm WC	
3	1137	bar	*
4	1138	mbar	
5	1141	PSI	*
6	1140	Atm	
7	1133	KPa	
8	1132	MPa	
9	1145	Kgf/cm ²	
10	1157	mm HG	
11	1146	inH2O ("WC)	*
12	1155	"HG	
13	1130	Pascal (limited use)	

*) Units will be shows on display in text.

If pressure units cannot be changed to your selection, "NA" will appear in the display (Not Applicable). Another selection should be made.

In this menu some parameters of the level transducer block can be adjusted.

0 Escape function from the transducer block menu

1 CAL_POINT_LOW

- Zero adjustment (Zero). Use the ↓ [ZERO] and ↑ [SPAN] push buttons to adjust. Confirm with [PROG].

2 CAL_POINT_HIGH

- Span adjustment (Span). Use the ↓ [ZERO] and ↑ [SPAN] push button. The value can be adjusted between minimum span en high sensor limit. Confirm with [PROG].

3 CANCEL_MOUNTING_EFFECT

Options:

- Esc: Escape from menu without changes.
- r.Set: When using this option the original factory setting will be valid
- Set: Perform cancel mounting position effect function

Confirm your selection with [PROG].

4 SENSOR_UNIT / SEC_VAL_2_UNIT

Change the sensor units.

UNIT TABLE:

	CODE	UNIT	
1	1521	mH2O (mWC)	*
2	1149	mm WC	
3	1137	bar	*
4	1138	mbar	
5	1141	PSI	*
6	1140	Atm	
7	1133	KPa	
8	1132	MPa	
9	1145	Kgf/cm ²	
10	1157	mm HG	
11	1146	inH2O ("WC)	*
12	1155	"HG	
13	1130	Pascal (limited use)	

*) Units will be shows on display in text.

If pressure units cannot be changed to your selection, "NA" will appear in the display (Not Applicable). Another selection should be made.

5 TEMPERATURE UNIT

Change the units of the sensor temperature

Options:

- CELC: Celsius (unit code = 1001)
- FAHr: Fahrenheit (unit code = 1002)
- CELU: Kelvin (unit code = 1000)

Push [PROG] to confirm.

6 CAL_TYPE

Change type of calibration

Options:

- 0 Offline/Dry (no use of test pressure)
- 1 Online (use of test pressure)
- 2 Pressure (transmitter is limited to pressure transmitter functionality, no level transmitter functionality)

7 RESET_MIN_SENSOR_VAL

Reset measured minimum sensor value. The minimum value that is measured will be reset to the current sensor (pressure) value.

8 RESET_MAX_SENSOR_VAL

Reset measured maximum sensor value. The maximum value will be reset to the current sensor (pressure) value.

9 RESET_MIN_TEMPERATURE_VAL

Reset measured minimum sensor temperature value. The minimum sensor

temperature value will be reset to the current sensor temperature value.

- 10 RESET_MAX_TEMPERATURE_VAL
Reset measured maximum sensor temperature value. The maximum sensor temperature value will be reset to the current sensor temperature value.
- 11 EXTENDED_CONFIG
Use this option for quick adjustments for simple applications.
Options:
- Off configure the transmitter (function blocks) fast and easy.
 - On configure the transmitter (function blocks) by checking all parameters.

When EXTENDED_CONFIG is adjusted to OFF, all pressure or level related parameters are scaled to a 1 to 1 base. This means: when, for example, SCALE_IN_LOW is changed in the transducer block, the IN_SCALE and OUT_SCALE parameters will be adjusted to the same value. This results in a 1 to 1 scale function between the transducer block and the analog input block. The OUT-value (in the analog input block) will get the same unit as the sensor value in the transducer block.

When a scaling function (not equal to a 1 to 1 base) is needed, for example conversion to a value that can be used by a PLC, please change EXTENDED_CONFIG to ON.

Ai.bL

Analog Input Block:

UtiL

Utility menu:

This menu contains some utility tools.

- 0 Escape function from the utility menu
- 1 ADJUST NETWORK ID
Default the network ID is adjusted to 126 (configuration or commissioning address). Using this menu the network ID can be adjusted between 3 and 126. When NO_ADD_CHG is set by profibus function DDLM_SET_SLAVE_ADD, NO_ADD_CHG will be overruled. In other words: the address adjusted in this menu will always be set.

note: Data-exchange is not possible for devices set to network ID 126.

- 2 DISPLAY READOUT
Options:
- Unit Display reads out SENSOR_VALUE.
 - PerC Display reads out percent of range *.
 - tEnP Display reads out sensor temperature.
 - Out Display reads out OUT-value of the analog input block.

*) This will be the percent value of the adjusted measuring range.

- 3 SIMULATE PROFILE V3.0

The Klay Series 2000PA PROFIBUS PA transmitters are tested for certification using profile V3.01. Because many (older) Profibus program-tools do not recognize a profile V3.01 device, there is this option to simulate Profile V3.0. Standard setting is SIMULATE PROFILE V3.0 **ON**.

4 RESPONSE TIME DISPLAY KEYS

In this menu the display key response time can be adjusted. This is the time how long you have to press a display key before you enter the menu-mode. Using the ↓ [ZERO] and ↑ [SPAN] buttons, the response time can be adjusted (0.0 to 5.0 seconds).

5 INFO MENU

This menu shows some general information about the settings of the device. The following information is displayed:

- Actual Network Id of the device
- Type of device (pressure or level transmitter)
- Actual identnumber
- Write protection on or off
- Modus: ONL (=currently in data-exchange) or OFFL
- Software revision

Note: Type of device, revision and network ID is also shown on the display at start-up.

9. PROFIBUS:

9.1 PA INTERFACE:

The Profibus communications part can be split into two parts: Cyclic communication (DP-V0) and an a-cyclic communications port (DP-V1).

The cyclic communications part is used when the slave is communicating with a class 1 master and/or the slave also works in data-exchange modus.

A-cyclic communication is usually used for commissioning purposes.

9.2 CYCLIC COMMUNICATIONS (DP-V0):

For proper operation using cyclic communication, the next settings have to be made: network id, ident number and configuration of the slave.

9.2.1 SETTING THE SLAVE'S NETWORK ID:

Default the slave network id is set to 126. This address is used for configuration / commissioning purposes.

The network address can be set using two different methods: by using the push-button on the display of the device, or by using profibus software.

Adjusting the network address by using the push button on the display:

- Press [PROG] and wait until 'ESC' appears on the display.
- Press ↑ [SPAN] until Util appears on the display.
- Confirm by pressing [PROG]. Now 0 will appear on the display.
- Press ↑ [SPAN] once. The display shows 1.
- Confirm by pressing [PROG].
- The actual network address will appear on the display.
- By using ↑ [SPAN] and ↓ [ZERO] the new value of the network address can be changed.

- Confirm the new address by pressing [PROG]. The slave will set its network address to the new value.

note: The new network address for the device should not already be used by another device in the network. The slave cannot check if the new address is already used. A network containing two devices with the same address can cause disruptions in communications.

Adjusting the network address by using profibus-software:

The way of setting the network address of a device by using profibus software depends on the kind of software you are using. Check the manual of the concerning software.

9.2.2 IDENTNUMBER AND GSD-FILE:

The ident number of the device shows what kind of a device it is. The Series 2000PA Pressure and Series 2000PA Level can be set to three different ident numbers:

- Profile Specific (9700_{hex})
- Manufacturer Specific ID number Profile V3.0 (0A2A_{hex} for the Series 2000PA Pressure and 0A29_{hex} for the Series 2000PA Level)

Default the ident number of the device is set to Manufacturer Specific ID number Profile V3.0.

9.2.3 SETTING THE IDENTNUMBER:

There are two ways to set the ident number: by using the keys on the display, or by using configuration software (a-cyclic communication).

Setting Ident number by using the keys on the display:

- press [PROG] and wait until 'ESC' lights up on the display.
- press ↑ [SPAN] until Ph.bl appears on the display.
- Confirm by pressing [PROG]. 0 will appear on the display.
- press ↑ [SPAN] once. 1 will appear on the display.
- Confirm by pressing [PROG].
- The actual ident number (for example 0A2A) will appear on the display.
- By pressing ↑ [SPAN] or ↓ [ZERO] the new ident number can be selected.
- Confirm by pressing [PROG]. The device will set to the new ident number

Note: the ident number of the device can only be changed when the device is not in data-exchange mode. When the device is in data-exchange and the ident number is attempted to change, the text 'Prot' will appear on the display and the new ident number will be rejected.

Setting ident number by using configuration software:

See chapter 9.3: a-cyclic communication

9.2.4 USING GSD-FILES:

The GSD-file is used to configure a network. On the basis of the information provided by the GSD-file, the number of input and output bytes of a device can be selected.

9.2.4.1 DEVICE SET TO MANUFACTURER SPECIFIC IDENTNUMBER:

If a slave is set to the manufacturer specific ident number, the following GSD-file has to be used: KLAY02A2.GSD¹ for a pressure device and KLAY02A9.GSD for a level device.

The device can be set to the following configurations:

- 1 module: pressure (or level) + status
- 1 module + empty module: pressure (or level) + status
- 2 modules: pressure (or level) + status and temperature + status. This can be selected by using one of the following configurations²:
 - 0x94: (1 module short configuration)
 - 0x42, 0x84, 0x08, 0x05: (1 module extended configuration)
 - 0x94, 0x00: (1 module short configuration + empty)
 - 0x94, 0x094: (2 modules short configuration)
 - 0x42, 0x84, 0x08, 0x05, 0x00: (1 module extended configuration + empty)
 - 0x94, 0x42, 0x84, 0x08, 0x05: (2 modules short + extended configuration)
 - 0x42, 0x84, 0x08, 0x05, 0x94: (2 modules extended + short configuration)
 - 0x42, 0x84, 0x08, 0x05, 0x42, 0x84, 0x08, 0x05: (2 modules extended configuration)

9.2.4.2 DEVICE SET TO PROFILE SPECIFIC IDENTNUMBER:

All profibus PA devices certified for PA Profile V3.0 have to support the profile specific ident number. In case of the Series 2000PA Pressure/Level this identnumber is 9700_{hex} (profile specific ident number for devices containing 1 analog input block.)

By using this ident number a kind of plug and play functionality is created. In other words PA devices of different manufacturers, which support PA Profile V3.0, are fully interchangeable without reconfiguring your network. The GSD-file to use: PA139700.GSD.

This GSD supports 1 module that can be configured by using one of the following configuration byte sets:

- 0x94: (1 module short configuration)
- 0x42, 0x84, 0x08, 0x05: (1 module extended configuration)

The output is a representative value of the pressure or level, also provided with a status byte.

¹ These GSD-files can be downloaded from the internet. www.klay-instruments.com under section downloads

² for an explanation of the coding of configuration bytes check the profibus standard.

9.2.5 CONSTRUCTION OF THE CYCLIC DATA (OUT-VALUE):

The cyclic data consists of 5 or 10 data bytes, depending on the amount of modules that are configured (1 respectively 2 modules).

Per module there are 5 bytes, representing: VALUE & STATUS.

9.2.5.1 ENCODING OUT-VALUE:

First 4 bytes are an IEEE754 floating point representation of the measured value. The last byte (byte #4) represents the status of this value.

Example:

A pressure transmitter using ident number 0A2A is configured as a device containing 2 modules. The send (input)data can look like this:

<i>Byte 0</i>	<i>Byte 1</i>	<i>Byte 2</i>	<i>Byte 3</i>	<i>Byte 4</i>	<i>Byte 5</i>	<i>Byte 6</i>	<i>Byte 7</i>	<i>Byte 8</i>	<i>Byte 9</i>
0x41	0x20	0x00	0x00	0x80	0x42	0x96	0x00	0x00	0x80

N.b. 0x00 is a hexadecimal notation of a decimal 0, (0x0A = 10 decimal)

Byte 0 to byte 4 represents the data of module 1 and byte 5 to byte 9 represents the data of module 2.

Byte 0 – 3: representation of: 10,0
 Byte 4: status 0x80

Byte 5 – 8: representation of: 75,0
 Byte 9: status 0x80

For an explanation of the encoding and decoding according to IEEE754 floating point encoding see appendix D.

9.2.5.2 ENCODING STATUS BYTE:

The status represents the condition of the provided value. This code is divided into three groups: Quality, substatus en limits.

Quality		Substatus				Limits		Meaning
BIT #7	BIT #6	BIT #5	BIT #4	BIT #3	BIT #2	BIT #1	BIT#0	
0	0	*	*	*	*	*	*	BAD
0	1	*	*	*	*	*	*	UNCERTAIN
1	0	*	*	*	*	*	*	GOOD (N.C.)*
1	1	*	*	*	*	*	*	GOOD (CAS)*
*	*	*	*	*	*	*	*	
*	*	*	*	*	*	0	0	O.K.
*	*	*	*	*	*	0	1	low limited
*	*	*	*	*	*	1	0	high limited
*	*	*	*	*	*	1	1	constant

Table 9.1

* N.C. = Not Cascaded

* CAS = Cascaded

When a status byte is BAD, the OUT-value will behave according to the settings of parameters FSAFE_ACTION and FSAFE_VALUE. These parameters are defined in the Analog Input Function block.

The meaning of sub status depends on the value of the quality bits. In the next table there are some possible status values

Status	Meaning	Priority
0x80	O.K.	Low
0x84	Good Update event: The value is OK, the block contains an active update event.	
0x88**	Good Active advisory alarm: The value is OK, the block contains an active warning alarm. **	
0x8c**	Good Active critical alarm: The value is OK, the block contains an active critical alarm. **	
0x40	Uncertain Non Specific: No reliable value, no specific reason.	
0x47	Uncertain Last Usable Value (LUV): there's no refresh for the value. (Possible reason: the display menu is entered using the display keys).	
0x48	Uncertain Substitute Value: a pre-defined value is submitted. Is used for failsafe.	
0x4c	Uncertain Initial Value: value is uncertain, device is busy performing an initialization.	
0x60	Uncertain Simulated Value: device is in simulation modus.	
0x0c	Bad Device Failure: incorrect value due to defective device.	
0x10	Bad Sensor Failure: incorrect value due to defective sensor.	
0x1c	Bad Out of Service: incorrect value due to no recalculation of the (function) block.	High

Table 9.2

** These status also provide high or low alarm.

Status	Meaning
0x89	Good Active advisory alarm low (LO_ALARM Analog Input block active)
0x8a	Good Active advisory alarm high (HI_ALARM Analog Input block active)
0x8d	Good Active critical alarm low (LO_LO_ALARM Analog Input block active)
0x8e	Good Active critical alarm high (HI_HI_ALARM Analog Input block active)

Table 9.3

9.3 A-CYCLIC COMMUNICATION (DP-V1):

By means of a-cyclic communication it is possible to configure the function blocks of the device. A profibus PA transmitter works according to a block model. This block model contains 4 blocks:

- **Device management:** block that contains a file-system for retrieving and saving parameters.
- **Physical block:** block containing general information and tools.
- **Transducer block:** block containing sensor/transmitter specific parameters
- **Analog Input block:** block containing parameters relating to the analog input function block.

These blocks and their parameters are maintained by Profibus PA workgroups. The transmitters provided by Klay Instruments follow the Profiles for pressure devices or Profiles for level devices, according to profile definition V3.01.

9.3.1 The PA-block model:

As stated before, the model exists of 4 blocks. A schematic representation is seen in figure 9.1

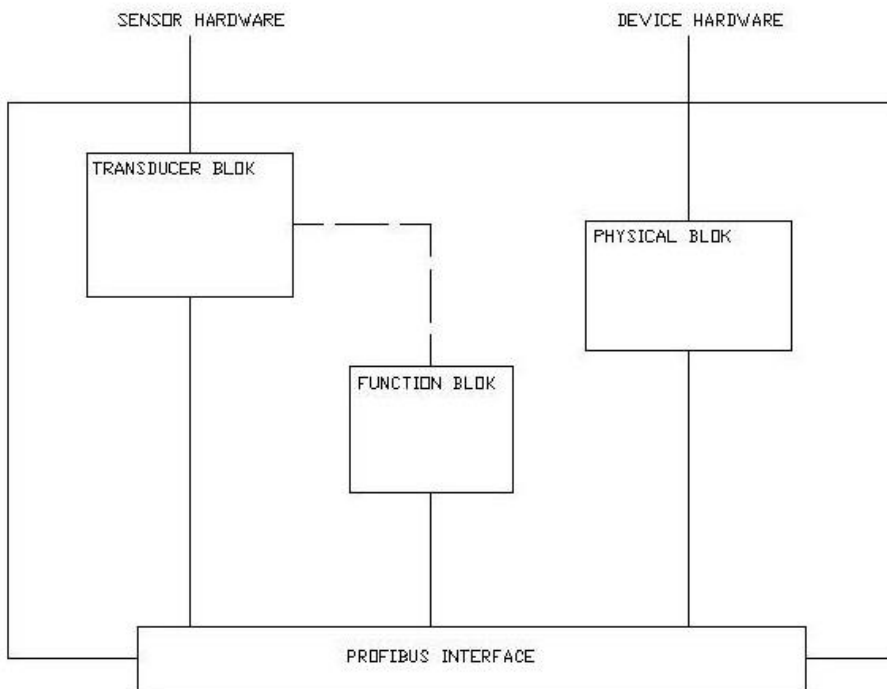

Figure 9.1

The complete system works as a slot / index system. It is possible to have more than one slot in a device. Every slot can contain a maximum of 255 indexes. Every single block contains a range of indexes. For example the analog input block has a index-range from 16 to 45. A slot can contain more than one blocks.

Two out of four blocks are connected. These blocks are: the transducer block and the analog input block. The output of the transducer block is connected to the input of the analog input block. The analog input block “generates” the out value that is provided the DP-network when the device is in data-exchange modus.

9.3.2 Device Management:

The device management contains a table, which contains information about the number of blocks, the location of parameters (slots / indexes) and the size of a block. Also called a directory. Table 9.4 shows the parameters of the device management.

Slot	Index	Parameter	Description	R/W
1	0	Directory_Object_Header	Header containing the following data: <ul style="list-style-type: none"> • Directory code • Directory version number • Number of directory objects • Number of directory entries • Index of the first dir. entry • Number of block types 	R
1	1	Composite_List_Directory_Entries Composite_Directory_Entries	Pointers to: <ul style="list-style-type: none"> • Abs index + offset first PB • Number of PB • Abs index + offset first TB • Number of TB • Abs index + offset first FB • Number of FB • Pointer to first block • Pointer to second block • • Pointer to # block 	R
1	2	Composite_Directory_Entries_Co ntinuos	(continued Composite_Directory_Entries)	R

PB = Physical Block

R/W = Read / Write

TB = transducer block

FB = function block

Table 9.4

By using this data, it is possible to approach all blocks of a PA device.

9.3.3 Physical block:

The Physical block contains the following data:

These parameters contain general purpose information of the device.

Slot	Index	Rel. Index	Parameter Name	Description	Data Type	Store	Size*	R/W	Reset	Possible data
0	16	0	BLOCK_OBJECT	This parameter describes the block model with further information about the block.	DS-32	Cnst	20	R		-
0	17	1	ST_REV	Revision counter. Will be upgraded when changing parameters with 'S' mark.	U16	N	2	R		-
0	18	2	TAG_DESC	This parameter contains an identification name for the block.	OS	S	32	R/W	I	Text 32 characters
0	19	3	STRATEGY	Used for clustering blocks	U16	S	2	R/W	I	0 – 65535
0	20	4	ALERT_KEY	Contains identification to locate alerts in the factory.	U8	S	1	R/W	I	0 – 255
0	21	5	TARGET_MODE		U8	S	1	R/W	F	Depends on MODE_BLK
0	22	6	MODE_BLK	Description of the operating mode of the block.	DS-37	D	3	R		-
0	23	7	ALARM_SUM	Description of the alert status of the block. (For example a status flag is set when a parameter is changed).	DS-42	D	8	R		-
0	24	8	SOFTWARE_REVISION	Revision number of the software	Vis.Str	Cnst	16	R		-
0	25	9	HARDWARE_REVISION	Revision number of the hardware	Vis.Str	Cnst	16	R		-
0	26	10	DEVICE_MAN_ID	Identification code of the manufacturer of the device (Klay Instruments = 117)	U16	Cnst	2	R		-
0	27	11	DEVICE_ID	Name of the device	Vis.Str	Cnst	16	R		-
0	28	12	DEVICE_SER_NUM	Serial number of the device	Vis.Str	Cnst	16	R		-
0	29	13	DIAGNOSIS	Detailed information about de condition of the device. If contains data, this will be shown on the DP-V0 by an extended diagnostics message.	OS*	D	4	R		-

0	30	14	DIAGNOSIS_EXTENSION	Extended diagnosis (not used)	OS	D	6	R		-
0	31	15	DIAGNOSIS_MASK	This parameter contains bitwise masked information which is diagnostics supporting.	OS	Cnst	4	R		-
0	32	16	DIAGNOSIS_MASK_EXTENSION	This parameter contains bitwise masked information which is extended diagnostics supporting.	OS	Cnst	6	R		-
0	33	17	DEVICE_CERTIFICATION	Certification of the device	Vis.Str	Cnst	32	R		-
0	34	18	WRITE_LOCKING	Software write protection	U16	N	2	R/W	F	0 – write protection active 2456 –write protection not active
0	35	19	FACTORY_RESET	Possibility to reset the device	U16	S	2	R/W	F	1 Reset to factory settings 2 Reset of parameters with reset class I 3 Reset of parameters with reset class F 2506 Warmstart device 2712 Reset bus-address to 126
0	36	20	DESCRIPTOR	Description of the device	OS	S	32	R/W	I	Text 32 character
0	37	21	DEVICE_MESSAGE	Extra parameter for extra device description	OS	S	32	R/W	I	Text 32 character
0	38	22	DEVICE_INSTALL_DATE	Date of installation	OS	S	16	R/W	I	Text 16 character
0	39	23	LOCAL_OP_ENA	Local adjustment	U8	N	1	R/W	F	Not supported
0	40	24	IDENT_NUMBER_SELECTOR	This parameter is used to adjust the ident number of the device. See chapter 9.2.4.	U8	S	1	R/W		0 Profile specific (0x9700) 1 Manufacturer Specific V 3.0 2 Manufacturer Specific V 2.0
0	41	25	HW_WRITE_PROTECTION	Status of the hardware write-protection. Not applicable for Klay devices..	U8	D	1	R		-
0	42	26	FEATURE	Shows what optional features are supported and switched on.	DS-68	N	8	R		-

9.3.4 Transducer block:

A device can contain several transducer blocks. A Klay Profibus PA transmitter can contain two kind of blocks: a pressure transducer block or a (hydrostatic) level transducer block. Both kind of transducer blocks are basic the same, but the level transducer block contains also a conversion from pressure to level/volume.

9.3.4.1 Pressure transducer block:

A schematic representation of the pressure transducer-block looks like figure 9.2.

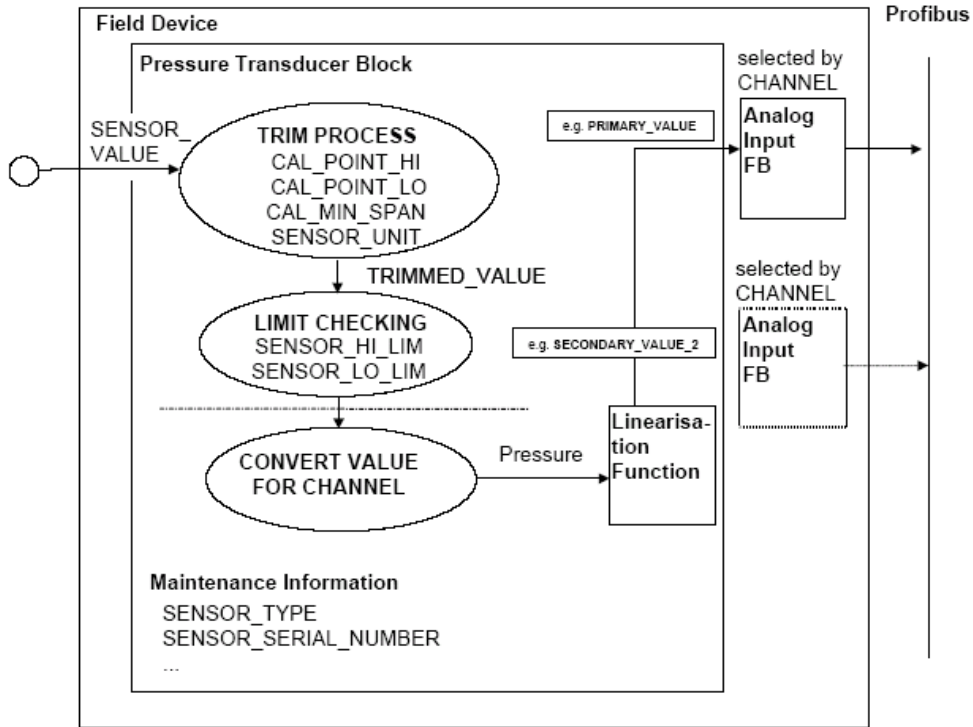

The measured sensor-value is used as input for the transducer block. At first all signal corrections take place. After applying all corrections the value is provided to the analog input block by using so-called channels. The value of channel is a composition of the slotnumber and the relative index (MSB= slot, LSB = relative index).

In case of a pressure transmitter the following channels are possible: 0112_{hex}, 011D_{hex} and 011F_{hex}. The parameters that can act as input for the analog input block are respectively: PRIMARY_VALUE, SECONDARY_VALUE_1 and SECONDARY_VALUE_2. Channel 0112_{hex} (274) is the default channel.

Table 9.6 shows all available parameters of the pressure block.

Slot	Index	Rel. Index	Parameter Name	Description	Data Type	Store	Size*	R/W	Reset	Supported data
1	61	0	BLOCK_OBJECT	This parameter describes the blockmodel with further information about the block.	DS-32	Cnst	20	R		-
1	62	1	ST_REV	Revision counter. Will be upgraded when changing parameters with 'S' mark.	U16	N	2	R		-
1	63	2	TAG_DESC	This parameter contains an identification name for the block.	OS	S	32	R/W	I	Text 32 characters
1	64	3	STRATEGY	Used for clustering blocks	U16	S	2	R/W	I	0 – 65535
1	65	4	ALERT_KEY	Contains identification to locate alerts in the factory.	U8	S	1	R/W	I	0 – 255
1	66	5	TARGET_MODE		U8	S	1	R/W	F	Depends on MODE_BLK
1	67	6	MODE_BLK	Description of the operating mode of the block.	DS-37	D	3	R		-
1	68	7	ALARM_SUM	Description of the alert status of the block. (For example a status flag is set when a parameter is changed).	DS-42	D	8	R		-
1	69	8	SENSOR_VALUE	Raw sensor value provided by sensor.	float	D	4	R		-
1	70	9	SENSOR_HI_LIM	Highest limit of the sensor.	float	N	4	R		-
1	71	10	SENSOR_LO_LIM	Highest limit of the sensor.	float	N	4	R		-
1	72	11	CAL_POINT_HI*	This parameters performs a kind of "Push Span" function. Entering a value to this parameter results in calibrating the urv to the actual pressure provided to the sensor.	float	S	4	R,W		Every value is accepted. The real adjusted upper range value will be returned. When the actual pressure is too low or too high, an error code is generated.

Table 9.6a

1	73	12	CAL_POINT_LO*	This parameter performs a kind of “push zero” function. Entering a value to this parameter results in calibrating the lrv to the actual pressure provided to the sensor	float	S	4	R,W	Every value is accepted. The real adjusted lower range value will be returned. When the actual pressure is too low or too high, an error code is generated
1	74	13	CAL_MIN_SPAN	This parameter contains the minimum span value.	float	N	4	R	-
1	75	14	SENSOR_UNIT	Sensor unit	U16	S	2	R,W	Supported units see appendix A
1	76	15	TRIMMED_VALUE	Value of the corrected sensor value	101 / DS33	D	5	R	-
1	77	16	SENSOR_TYPE	Type of sensor	U16	N	2	R	-
1	78	17	SENSOR_SERIAL_NUMBER	Serial number of the device	U32	N	4	R	-
1	79	18	PRIMARY_VALUE	Measured value, default input to analog input block.	101 / DS33	D	5	R	-
1	80	19	PRIMARY_VALUE_UNIT	Unit of PRIMARY_VALUE	U16	S	2	R,W	Supported units see appendix A
1	81	20	PRIMARY_VALUE_TYPE	Type of primary value	U16	S	2	R,W	Only 0 (pressure) is supported.
1	82	21	SENSOR_DIAPHRAGM_MATERIAL	This parameters contain a code representing the material used for the diaphragm.	U16	S	2	R,W	For codes see appendix A
1	83	22	SENSOR_FILL_FLUID	This parameters contain a code representing the kind of oil-filling.	U16	S	2	R,W	For codes see appendix A
1	84	23	SENSOR_MAX_STATIC_PRESSURE	This parameter shows the maximum permitted static pressure.	float	N	4	R	-
1	85	24	SENSOR_O_RING_MATERIAL	This parameters contain a code representing the material for the used o-ring	U16	S	2	R,W	For codes see appendix A
1	86	25	PROCESS_CONNECTION_TYPE	This parameters contain a code representing the type of process-connection.	U16	S	2	R,W	For codes see appendix A

Table 9.6b

1	87	26	PROCESS_CONNECTION_MATERIAL	This parameters contain a code representing the used process-connection .	U16	S	2	R,W		For codes see appendix A
1	88	27	TEMPERATURE	This parameter contains the actual process-temperature.	101 / DS33	D	5	R		-
1	89	28	TEMPERATURE_UNIT	Temperature units.	U16	S	2	R,W		Supported Units: <ul style="list-style-type: none"> • Kelvin (1000) • °Celsius (1001) • Fahrenheit (1002)
1	90	29	SECONDARY_VALUE_1	Value of secondary_value_1	101 / DS33	D	5	R		-
1	91	30	SECONDARY_VALUE_1_UNIT	Secondary_value_1 unit.	U16	S	2	R,W		Supported units appendix A
1	92	31	SECONDARY_VALUE_2	Value of secondary_value_2	101 / DS33	D	5	R		-
1	93	32	SECONDARY_VALUE_2_UNIT	Secondary_value_2 unit.	U16	S	2	R,W		fixed code: 1997 no unit
1	94	33	LIN_TYPE	This parameter contains the code of the actual type of linearization.	U8	S	1	R,W		Only 0 is supported
1	95	34	SCALE_IN*	This parameter contains the values for scaling of SV_1 to SV_2. Unit is the same as SV_1_UNIT.	float	S	8	R,W		All values
1	96	35	SCALE_OUT**	This parameter contain the values for scaling of SV_2 to PV. Unit is PV_UNIT.	float	S	8	R,W		All values
1	97	36	LOW_FLOW_CUT_OFF		float	S	4	R,W		NOT SUPPORTED
1	98	37	FLOW_LIN_SQRT_POINT		float	S	4	R,W		NOT SUPPORTED
1	99	38	TAB_ACTUAL_NUMBER		U8	N	1	R		NOT SUPPORTED
1	100	39	TAB_ENTRY		U8	D	1	R,W		NOT SUPPORTED
1	101	40	TAB_MAX_NUMBER		U8	N	1	R		NOT SUPPORTED
1	102	41	TAB_MIN_NUMBER		U8	N	1	R		NOT SUPPORTED

Table 9.6c

1	103	42	TAB_OP_CODE		U8	D	1	R,W		NOT SUPPORTED
1	104	43	TAB_STATUS		U8	D	1	R		NOT SUPPORTED
1	105	44	TAB_X_Y_VALUE		float	D	8	R,W		NOT SUPPORTED
1	106	45	MAX_SENSOR_VALUE	This parameter contains the maximum value of SENSOR_VALUE .	float	N	4	R,W		Every value is accepted and will reset this parameter to the actual SENSOR_VALUE
1	107	46	MIN_SENSOR_VALUE	This parameter contains the minimum value of SENSOR_VALUE.	float	N	4	R,W		Every value is accepted and will reset this parameter to the actual SENSOR_VALUE
1	108	47	MAX_TEMPERATURE	This parameter contains the maximum value of TEMPRATURE.	float	N	4	R,W		Every value is accepted and will reset this parameter to the actual TEMPERATURE_VALUE
1	109	48	MIN_TEMPERATURE	This parameter contains the minimum value of TEMPRATURE.	float	N	4	R,W		Every value is accepted and will reset this parameter to the actual TEMPERATURE_VALUE

Table 9.6d

* **CAL_POINT_LO** and **CAL_POINT_HI** are used to calibrate the transmitter using test pressure. These two parameters are coupled to **SCALE_IN**. So if **CAL_POINT_HI** and **CAL_POINT_LO** are changed, **SCALE_IN** will adapt these values. If the transmitter is calibrated without test pressure, **SCALE_IN** should be used. If **SCALE_IN** is changed, **CAL_POINT_LO** and **CAL_POINT_HI** will adapt these values.

** **SCALE_OUT** and PV_SCALE are also connected. If **SCALE_OUT** is changed, PV_SCALE will adapt these values. For an explanation of PV_SCALE see chapter 9.3.5.(Analog Input Block).

To find the various codes mentioned in the table, see appendix.

9.3.4.2 Level transducer block:

A schematic representation of the level transducer block looks like figure 9.3.

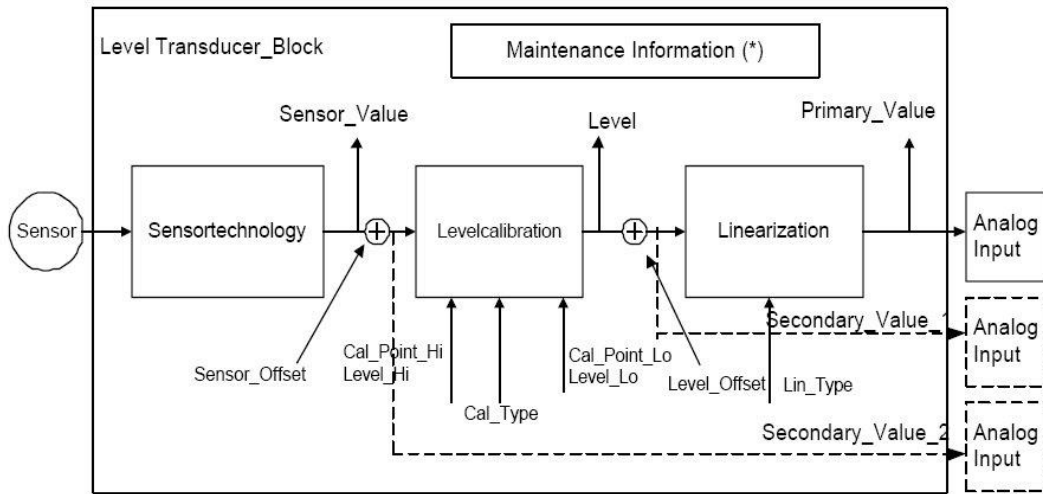

Figure 9.3

In the sensor technology block all measuring takes place. In the level block the calibration and conversion to level values takes place. To perform linearization (measuring volume, etc) there's the linearization block. As a result of the total block, primary value is provided to the analog input block. It is also possible to define sensor value (secondary_value_2) or level value (secondary_value_1) as input for the analog input block. Channel is used to define the input for the analog input block.

The parameter channel is composed of two variables: it is a composition of slot number and relative index (MSB = slot, LSB = relative index). In case of a level transmitter, the following channels are possible: 0108_{hex}, 010E_{hex} and 0110_{hex}. The parameter acting as input for the analog input block are respectively: PRIMARY_VALUE, SECONDARY_VALUE_1 (level) and SECONDARY_VALUE_2 (sensor value). Channel 0108_{hex} (264) is the default channel.

Table 9.7 shows all available parameters of the level transducer block. Figure 9.4 also gives a schematic representation of how parameters are related to each other.

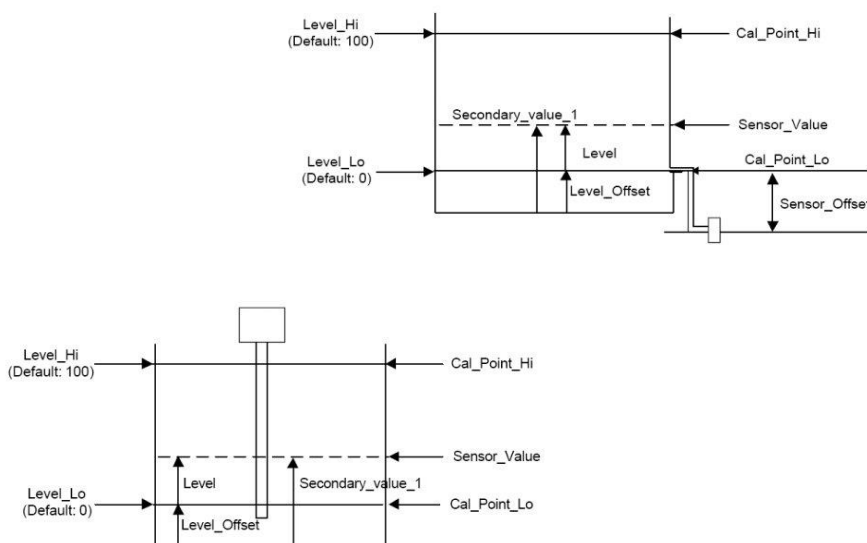

Figure 9.4

Slot	Index	Rel. Index	Parameter Name	Description	Data Type	Store	Size	R/W	Reset	Possible data
1	61	0	BLOCK_OBJECT	This parameter describes the block model with further information about the block.	DS-32	Cnst	20	R		-
1	62	1	ST_REV	Revision counter. Will be upgraded when changing parameters with 'S' mark.	U16	N	2	R		-
1	63	2	TAG_DESC	This parameter contains an identification name for the block.	OS	S	32	R/W	I	Text 32 characters
1	64	3	STRATEGY	Used for clustering blocks	U16	S	2	R/W	I	0 – 65535
1	65	4	ALERT_KEY	Contains identification to locate alerts in the factory.	U8	S	1	R/W	I	0 – 255
1	66	5	TARGET_MODE		U8	S	1	R/W	F	Depends on MODE_BLK
1	67	6	MODE_BLK	Description of the operating mode of the block.	DS-37	D	3	R		-
1	68	7	ALARM_SUM	Description of the alert status of the block. (For example a status flag is set when a parameter is changed).	DS-42	D	8	R		-
1	69	8	PRIMARY_VALUE	The primary value is the process value and used as input for the analog input block.	DS33	D	5	R		-
1	70	9	PRIMARY_VALUE_UNIT	This parameter contains the unit code for primary value.	U16	S	2	R,WR		For codes see table B
1	71	10	LEVEL	The parameter represents the level value	float	D	4	R		-
1	72	11	LEVEL_UNIT	This parameter contains the unit code of level.	U16	S	2	R,W		For codes see table B3
1	73	12	SENSOR_VALUE	Sensor value is the measuring value directly from the sensor.	float	D	4	R		
1	74	13	SENSOR_UNIT	This parameter contains the unit code for sensor value.	U16	S	2	R,W		For codes see table B2
1	75	14	SECONDARY_VALUE_1	secondary_value_1 = level + level offset and a status byte	D33	D	5	R		-
1	76	15	SECONDARY_VALUE_1_UNIT	This parameter contains the unit code of SECONDARY_VALUE_1. Unit code is the same as level unit.	U16	S	2	R,W		

Table 9.7a

1	77	16	SECONDARY_VALUE_2	Secondary_value_2 = sensor value + sensor offset	DS33	D	5	R		-
1	78	17	SECONDARY_VALUE_2_UNIT	This parameter contains the unit code for SECONDARY_VALUE_2. Unit code is the same as sensor unit.	U16	S	2	R,W		
1	79	18	SENSOR_OFFSET	This parameter contains the offset value for sensor value.	float	S	4	R,W		
1	80	19	CAL_TYPE	This parameter contains the code for type of calibration.	U8	S	1	R,W		For codes see table B1
1	81	20	CAL_POINT_LO*	This parameter contains the lower range value of sensor value.	float	S	4	R,W		
1	82	21	CAL_POINT_HI*	This parameter contains the upper range value of sensor value.	float	S	4	R,W		
1	83	22	LEVEL_LO	This parameter contains the lower range value for level	float	S	4	R,W		
1	84	23	LEVEL_HI	This parameter contains the upper range value for level	float	S	4	R,W		
1	85	24	LEVEL_OFFSET	This parameter contains the value of offset for level	float	S	4	R,W		
1	86	25	LIN_TYPE	Code for the actual linearization.	U8	S	1	R,W		For codes see table B6
1	87	26	LIN_DIAMETER	This parameter contain the diameter of the tank. (lin_type = 20)	float	S	4	R,W		
1	88	27	LIN_VOLUME	This parameter contains the volume of the used tank. (lin_type = 20)	float	S	4	R,W		
1	89	28	SENSOR_HIGH_LIMIT	Upper proces limit of the sensor	float	C	4	R		
1	90	29	SENSOR_LOW_LIMIT	Lower process limit of the sensor	float	C	4	R		
1	91	30	MAX_SENSOR_VALUE	This parameter contains the maximum value of SENSOR_VALUE	float	N	4	R,W		Every value is accepted and will reset this parameter to the actual SENSOR_VALUE
1	92	31	MIN_SENSOR_VALUE	This parameter holds the minimum value of SENSOR_VALUE	float	N	4	R,W		Every value is accepted and will reset this parameter to the actual SENSOR_VALUE
1	93	32	TEMPERATURE	This parameter holds the value of the process temperature.	float	D	4	R		

Table 9.7b

1	94	33	TEMPERATURE_UNIT	This parameter contains the unit code for the temperature.	U16	S	2	R,W	Options: <ul style="list-style-type: none"> • 1000: Kelvin • 1001: Celsius • 1002: Fahrenheit
1	95	34	MAX_TEMPERATURE	This parameter holds the minimum value of TEMPERATURE_VALUE.	float	N	4	R,W	Every value is accepted and will reset this parameter to the actual SENSOR_VALUE
1	96	35	MIN_TEMPERATURE	This parameter holds the minimum value of TEMPERATURE_VALUE.	float	N	4	R,W	Every value is accepted and will reset this parameter to the actual SENSOR_VALUE
1	97	36	TAB_ENTRY	Actual number of the lin table	U8	D	1	R,W	See appendix C
1	98	37	TAB_X_Y_VALUE	The X and Y value at the actual index of the table.	float	D	8	R,W	See appendix C
1	99	38	TAB_MIN_NUMBER	Minimum number of points used for the table.	U8	N	1	R	See appendix C
1	100	39	TAB_MAX_NUMBER	Maximum number of point used for the table.	U8	N	1	R	See appendix C
1	101	40	TAB_OP_CODE	Shows the state of the table.	U8	D	1	R,W	See appendix C
1	102	41	TAB_STATUS	Shows the status of the table. (Input ready / table ready / init table / ect)	U8	D	1	R	See appendix C
1	103	42	TAB_ACTUAL_STATUS	Shows the number of entered points	U8	N	1	R	See appendix C

Table 9.7c

* If CAL_TYPE = 1 (online); **CAL_POINT_LO** and **CAL_POINT_HI** are used to calibrate the transmitter with use of test pressure.
 If CAL_TYPE = 0 (Offline/dry); **CAL_POINT_LO** and **CAL_POINT_HI** are used to calibrate the transmitter without use of a test pressure.
 If CAL_TYPE = 2 (pressure); also no test pressure is needed for calibration.

9.3.5 Analog Input block:

The analog input block provides parameters concerning the behavior of the device and the out-value. There are parameters to adjust, damping, alarms, simulation, etc.

A schematic representation of the analog input block is shown in figure 9.5.

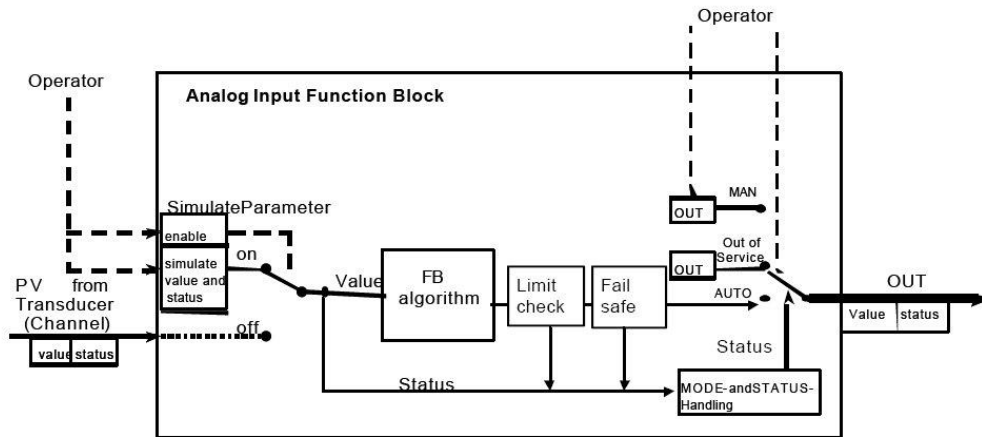

Figure 9.5

Normally the input of the block is provided to the analog input block via channel . This input runs through the sub-blocks ‘FB Algorithm’, ‘Limit check’ and ‘Failsafe’ and appears as OUT-value at the output of the analog input block.

The out-value is provided to a master in data-exchange mode. The status byte and operating modus is analyzed in the ‘MODE and STATUS handling’ block.

A schematic representation is shown in figure 9.6. The first block scales the input to a percent of scale value. This value is (after linearization) scaled to OUT_SCALE. After this some filtering and limit checking is done.

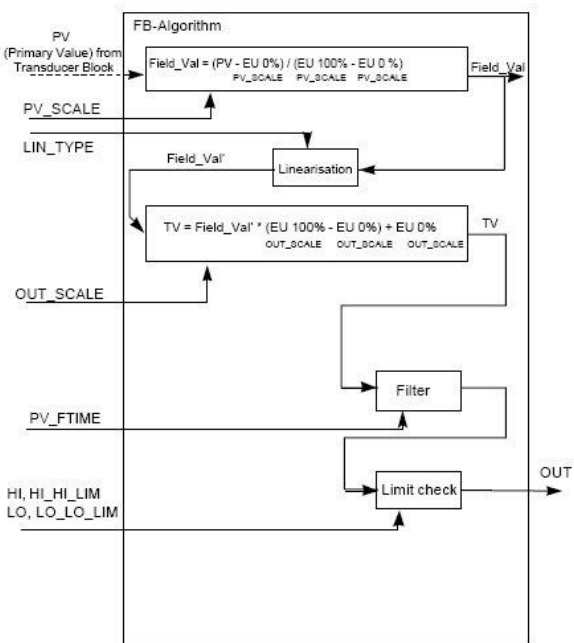

Figure 9.6

Table 9.8 shows all available parameters of the analog input block.

Slot	Index	Rel. Index	Parameter Name	Description	Data Type	Store	Size*	R/W	Reset	Possible data
1	16	0	BLOCK_OBJECT	This parameter describes the block model with further information about the block.	DS-32	Cnst	20	R		-
1	17	1	ST_REV	Revision counter. Will be upgraded when changing parameters with 'S' mark.	U16	N	2	R		-
1	18	2	TAG_DESC	This parameter contains an identification name for the block.	OS	S	32	R/W	I	Text 32 characters
1	19	3	STRATEGY	Used for clustering blocks.	U16	S	2	R/W	I	0 – 65535
1	20	4	ALERT_KEY	Contains identification to locate alerts in the factory.	U8	S	1	R/W	I	0 – 255
1	21	5	TARGET_MODE		U8	S	1	R/W	F	Depending on MODE_BLK
1	22	6	MODE_BLK	Description of the operating mode of the block.	DS-37	D	3	R		-
1	23	7	ALARM_SUM	Description of the alert status of the block. (For example a status flag is set when a parameter is changed).	DS-42	D	8	R		-
1	24	8	BATCH	Identification parameters used for batch process (according to IEC 61512 Part 1)	DS-67	S	10	R/W	I	
1	26	10	OUT	This parameter holds the actual out value and a status byte. It is (in data exchange) provided to a master as cyclic value.	101	D	5	R ¹		-
1	27	11	PV_SCALE	This parameter is used to convert the PV_VALUE from the transducers block to a percent of scale value. Unit code is the same as PV_UNIT.	FLOAT	S	8	R/W	F	
1	28	12	OUT_SCALE	Using this parameter the percent of scale value is scaled to OUT_VALUE.	DS-36	S	11	R/W	F	-
1	29	13	LIN_TYPE	Type of linearization	U8	S	1	R/W	F	0 (not supported)

1	30	14	CHANNEL	This parameter holds the channel code of the analog input block.	U16	S	2	R,W	F	274, 285, 287
1	32	16	PV_TIME	This parameter hold the damping time.	float	S	4	R/W	F	0 – 25 seconds
1	33	17	FSAFE_TYPE	This parameter hold the type of failsafe behavior.	U8	S	1	R,W	F	0 FASEF_VALUE default value 1 last chosen value 2 Calculated value
1	34	18	FSAFE_VALUE	This parameter is used for FSAFE_TYPE option 0 and holds the failsafe value.	float	S	4	R/W	F	Only realistic value
1	35	19	ALARM_HYS	Hysterasy used for the alarmpoints.	float	S	4	R/W	F	All realistic values
1	37	21	HI_HI_LIM	High critical alarm.	float	S	4	R/W	F	All realistic values
1	39	23	HI_LIM	High advisory alarm.	float	S	4	R/W	F	All realistic values
1	41	25	LO_LIM	Low advisory alarm	float	S	4	R/W	F	All realistic values
1	43	27	LO_LO_LIM	Low critical alarm	float	S	4	R/W	F	All realistic values
1	46	30	HI_HI_ALM	This alarm is shown at a high critical alarm	DS-39	D	16	R		-
1	47	31	HI_ALM	This alarm is shown at a high advisory alarm	DS-39	D	16	R		-
1	48	32	LO_ALM	This alarm is shown at a low advisory alarm	DS-39	D	16	R		-
1	49	33	LO_LO_ALM	This alarm is shown at a low critical alarm	DS-39	D	16	R		-
1	50	34	SIMULATE	This parameter is used for simulation	DS-50	S	6	R/W	F	<ul style="list-style-type: none"> On/off All realistic status values All realistic input values
1	51	35	OUT_UNIT_TEXT	This parameter hold a unit description in text-form.	OS	S	16	R/W		

Table 9.8b

1) If MODE_BLOCK is in manual mode, OUT-value can be written.

9.3.6 Klay specific parameters

The Klay specific parameters are parameters that are specific to Klay transmitters. These parameters are added for special functions. These special parameters are listed in table 9.9

Slot	Index Press.	Index level	Rel. Index Press.	Rel. Index Level	Parameter Name	Description	Data Type	Store	Size*	R/W	Reset	Possible data
1	120	114	59	53	MOUNTING_EFFECT	This parameter perform the cancel mounting affect function.	U8	S	1	R/W		NOT IMPLEMENTED
1	121	115	60	54	DISPLAY_READING	This parameter select a readout on the display.	U8	S	1	R/W		Options: 1. Sensor unit 2. Percent of range 3. Temperature 4. OUT-value
1	122	116	61	55	SPECIFIC_DENSITY	This parameter is used to change the specific density.	float	S	4	R/W		NOT IMPLEMENTED
1	123	117	62	56	LOCAL_PROTECTION	This parameter is used to switch on or off the protection for changes using the display keys.	U8	S	1	R/W		NOT IMPLEMENTED
1	124	118	63	57	COM_PROTECTION	This parameter equals the WRITE_PROTECTION parameter of the physical block.	U8	S	1	R/W		NOT IMPLEMENTED
1	125	119	64	58	BUTTON_RESPONSE_TIME	This parameter is used to change the response time of the display keys.	U8	S	1	R/W		NOT IMPLEMENTED
..
1	130	124	69	63	EXTENDED_CONFIG	This parameter is used to change EXTENDED_CONFIG.	U8	s	1	R/W		Options: • 0: Off • 1: On

Table 9.9

9.4 Configuring a PA-SLAVE

A 2000PA-transmitter (pressure or level) can be configured using EXTENDED_CONFIG on or off. There's also a difference between configuring a pressure transmitter and a level transmitter.

By use of an example the configuring of a PA-transmitter shall be explained.

9.4.1 Pressure transmitter: EXTENDED_CONFIG off

In this example a transmitter will be configured in a fast and simple way. This way of configuring can be used when the out-value has to be a direct representation of the sensor measuring value.

Procedure: Switch EXTENDED_CONFIG to off. Next the measuring range has to be adjusted. This is normally done in the pressure transducer block or the analog input block.

When adjusting the measuring range using the transducer block, two methods can be used: using test pressure or using no test pressure.

Using test pressure:

If using test pressure, parameters CAL_POINT_LO and CAL_POINT_HI have to be used. First connect to a test pressure representing CAL_POINT_LO. When the test pressure is stabilized, enter a value for CAL_POINT_LO. The transmitter will measure the pressure and will adjust CAL_POINT_LO to this value.

To adjust the span follow the same procedure, but now, the test pressure has to correspond to the desired span. When the pressure is stabilized, enter a value for CAL_POINT_HI. The transmitter will adjust CAL_POINT_HI to the connected pressure.

When an error level is received, the following situation can cause this error: the connected test pressure is too low (< MINIMUM_SPAN) or the test pressure is outside the sensor limits (SENSOR_LO_LIM or SENSOR_HI_LIM)

No use of test pressure:

To adjust the transmitter without using test pressure, use the next parameters: SCALE_IN (max and min) or SCALE_OUT(max and min). Example: enter the desired zero value for SCALE_IN_MIN and enter the desired maximum value of the measuring range for SCALE_IN_MAX.

All other scale-functions will be recalculated to a 1 to 1 scale. As a result OUT is a representation of SENSOR_VALUE.

It's also possible to adjust these values using the analog input block. Then OUT_SCALE or PV_SCALE have to be used. For example enter the desired measuring range in OUT_SCALE. All preceding parameters will be recalculated. Because the number of SENSOR_UNIT is limited, it is possible there will be an error message. Use a different unit for OUT_SCALE. It's also possible that the measuring range is outside the sensor limits.

Also the damping (PV_TIME) and alarms (HI_HI_LIM, HI_LIM, LO_LIM, LO_LO_LIM en ALARM_HYS) can be adjusted. All these parameters are in the analog input block.

9.4.2 Pressure transmitter: EXTENDED CONFIG on

In this example a transmitter will be configured in an extended way. For example this can be useful when the OUT-value has to be converted to a value that is supported by the PLC.

Procedure: Switch EXTENDED_CONFIG to on and adjust the measuring range using the parameters in the pressure .

When adjusting the measuring range using the transducer block, two methods can be used: by using test pressure or using no test pressure.

Using test pressure:

Using test pressure the parameters CAL_POINT_LO and CAL_POINT_HI have to be used. First connect to a test pressure representing CAL_POINT_LO. When the test pressure is stabilized, enter a value for CAL_POINT_LO. The transmitter will measure the pressure and will adjust CAL_POINT_LO to this value.

To adjust the span follow the same procedure, but now the test pressure has to correspond the desired span. When the pressure is stabilized, enter a value for CAL_POINT_HI. The transmitter will adjust CAL_POINT_HI to the connected pressure.

When an error message is received, it could be caused by the following situation: the connected test pressure is too low (< MINIMUM_SPAN) or the test pressure is outside the sensor limits (SENSOR_LO_LIM or SENSOR_HI_LIM).

If / when the value of CAL_POINT_HI or CAL_POINT_LO is changed SCALE_IN will adapt these new values. These parameters are connected.

No use of test pressure:

To adjust the transmitter without using test pressure, use the next parameter: SCALE_IN (max and min). Example: enter for SCALE_IN_MIN the desired value for zero and enter for SCALE_IN_MAX the desired maximum value of the measuring range.

CAL_POINT_LO and CAL_POINT_HI will adapt these values.

When a 1 to 1 scaling between SCALE_IN and SCALE_OUT is desired, both parameters must have equal ranges. To obtain a 1 to 2 scaling, SCALE_OUT has to be twice the range of SCALE_IN.

It is possible to make some adjustments for, for example a PLC. Use OUT_SCALE for this.

Example: PV_SCALE_0 = 0 and PV_SCALE = 0,1 (unit codes are left out of consideration). For example you need a range of 0 – 32000. Enter for OUT_SCALE_0 the value of 0, and for OUT_SCALE_100 the value of 32000. Now OUT will be in the range of 0 – 32000.

Also the damping (PV_TIME) and alarms (HI_HI_LIM, HI_LIM, LO_LIM, LO_LO_LIM and ALARM_HYS) can be adjusted. All these parameters are in the analog input block.

9.4.3 Level transmitter: EXTENDED CONFIG off

In this example a transmitter is configured in a fast and simple way. This way of configuring is possible when the out-value has to be a direct representation of the sensor measuring value.

Procedure: Switch EXTENDED_CONFIG to off. Next the measuring range has to be adjusted. This is done in the level transducer block or the analog input block.

To adjust the measuring range of the transmitter, two methods can be used: by using test pressure (CAL_TYPE = 1 ONLINE) or by using no test pressure (CAL_TYPE = 0 DRY).

Using test pressure (CAL_TYPE = 1):

First fill the used tank to the point that equals empty. Enter a value for CAL_POINT_LOW.

The transmitter will measure and will adjust CAL_POINT_LOW to this value.

To adjust span, fill the tank to the point that equals 'full'. Enter a value for CAL_POINT_HIGH. The transmitter will adjust CAL_POINT_HIGH to the actual pressure.

If the connected pressure is too low or too high there will be an error message.

No use of test pressure (CAL_TYPE = 0/2):

Use CAL_POINT_LOW and CAL_POINT_HIGH to adjust the transmitter to the desired range. Use CAL_POINT_LOW for empty/zero and CAL_POINT_HIGH for full/span.

If CAL_TYPE = 2 the transmitter will only have the functionality of a pressure transmitter. When EXTENDED_CONFIG is off, all following (scaling) parameters will be recalculated to a 1 to 1 base. OUT will equal SENSOR_VALUE.

If CAL_TYPE = 0 or 1 the transmitter has the functionality of a level transmitter. The following parameter will only be recalculated when LEVEL-parameters are changed. The SENSOR-parameters will be scaled to LEVEL-parameters (see figure 9.3 and 9.4, chapter 9.3.4.2),

If a linearization is used, the level value can be converted to a volume value. For an explanation of using the linearization see appendix.

Also the damping (PV_TIME) and alarms (HI_HI_LIM, HI_LIM, LO_LIM, LO_LO_LIM and ALARM_HYS) can be adjusted. All these parameters are in the analog input block.

9.4.4 Level transmitter: EXTENDED CONFIG on

In this example a transmitter will be configured in an extended way. For example this can be useful when the OUT-value has to be converted to a value that is supported by the PLC.

Procedure: Switch EXTENDED_CONFIG to on and adjust the measuring range using the parameters in the pressure .

To adjust the measuring range of the transmitter, two methods can be used: by using test pressure (CAL_TYPE = 1 ONLINE) or by using no test pressure (CAL_TYPE = 0 DRY).

Use of test pressure (CAL_TYPE = 1):

Switch CAL_TYPE to 1. Using test pressure the parameters CAL_POINT_LOW and CAL_POINT_HIGH have to be used. First apply a test pressure representing CAL_POINT_LOW. When the test pressure is stabilized, enter a value for CAL_POINT_LOW. The transmitter will measure the pressure and will adjust CAL_POINT_LOW to this value.

To adjust the span follow the same procedure, but now the test pressure has to correspond the desired span. When the pressure is stabilized, enter a value for CAL_POINT_HIGH. The transmitter will adjust CAL_POINT_HIGH to the connected pressure.

When an error message is received, the applied pressure is outside the transmitter limits.

No use of test pressure (CAL_TYPE = 0/2):

Switch CAL_TYPE to 0 (level measurement) or 2 (only pressure). To adjust the transmitter without using test pressure, use the next parameter: CAL_POINT_LOW and CAL_POINT_HIGH. Example: enter for CAL_POINT_LOW the desired value for zero (empty tank) and enter for CAL_POINT_HIGH the value of span (tank full).

If CAL_TYPE = 2 the transmitter will only have the functionality of a pressure transmitter. When EXTENDED_CONFIG is off, all following (scaling) parameters will be recalculated to a 1 to 1 base. OUT will equal SENSOR_VALUE.

If CAL_TYPE = 0 or 1 the transmitter has the functionality of a level transmitter. The following parameter will only be recalculated when LEVEL-parameters are changed. The SENSOR-parameters will be scaled to LEVEL-parameters (see figure 9.3 and 9.4, chapter 9.3.4.2),

If a linearization is used, the level value can be converted to a volume value. For an explanation of using the linearization see appendix.

If a 1 to 1 scaling between SCALE_IN and SCALE_OUT is desired, both parameters must have equal ranges. To obtain a 1 to 2 scaling, SCALE_OUT has to be twice the range of SCALE_IN.

It is possible to make some adjustments for, for example a PLC. Use OUT_SCALE for this. Example: PV_SCALE_0 = 0 and PV_SCALE = 0,1 (unit codes are left out of consideration). For example you need a range of 0 – 32000. Enter for OUT_SCALE_0 the value of 0, and for OUT_SCALE_100 the value of 32000. Now OUT will be in the range of 0 – 32000.

Also the damping (PV_TIME) and alarms (HI_HI_LIM, HI_LIM, LO_LIM, LO_LO_LIM and ALARM_HYS) can be adjusted. All these parameters are in the analog input block.

10. SPECIFICATIONS

<i>Manufacturer:</i>	Klay Instruments The Netherlands			
<i>Instrument:</i>	Series 2000 Profibus PA			
<i>Output:</i>	Profibus PA			
<i>Accuracy</i>	0,1% of adjusted span			
<i>Ranges:</i>	Adjustable span ranges		Max. overpressure.	
	Series 2000:	0-0,1 bar	0-0,4 bar	6,4 bar
		0-0,3 bar	0-1,2 bar	10,5 bar
		0-1 bar	0-10 bar	30 bar
		0-5 bar	0-30 bar	60 bar
		0-20 bar	0-60 bar	120 bar
	Series 2000 (SAN):	0-0,04 bar	0-0,4 bar	6,4 bar
		0-0,1 bar	0-1,2 bar	10,5 bar
		0-1 bar	0-10 bar	30 bar
		0-5 bar	0-30 bar	60 bar
		0-20 bar	0-60 bar	120 bar
	Series CER 2000:	0-0,2 bar	0-0,8 bar	5 bar
0-0,8 bar		0-2 bar	10 bar	
0-2 bar		0-10 bar	30 bar	
0-10 bar		0-40 bar	120 bar	
0-40 bar		0-200 bar	350 bar	
0-150 bar		0-320 bar	600 bar	
<i>Process temperature:</i> ³				
Series 2000:	-20°C tot +80°C (-4 °F to 176 °F)			
Series 2000 (SAN):	-20°C tot +100°C (130°C / 30 min) (-4 °F to 212 °F)			
Series CER-2000	-20°C tot +100°C (-4 °F to 212 °F)			
<i>Temperature effect:</i>	0,015% / K			
<i>Damping:</i>	0,5 s to 25 sec (0,5 sec = Std. Damping)			
<i>Protection grade</i>	IP66			
<i>Material:</i>				
<i>Housing</i>	AISI 304			
<i>“wetted” parts:</i>	AISI 316			
<i>Profibus:</i>				
<i>PA function:</i>	Slave Profile V3.01			
<i>Transmission speed:</i>	31.25 kb/sec			
<i>Power supply:</i>	12 Vdc to 30 Vdc			
<i>Current consumption:</i>	11 mA ± 1 mA			
<i>Fault current:</i>	11 mA ± 1 mA			

Table 10.1

³

For higher temperatures use other kind of pressure transmitters. Contact Klay Instruments for information.

APPENDIX A SERIES2000 PA PRESSURE

A1 Table Supported Sensor units / Primary Value units / Secondary Value 1 units:

Pressure	
Unit	Code
kPa	1133
bar	1137
psi	1141
inHG	1155
mH2O	1521
mmH2O	1149
mbar	1138
atm	1140
MPa	1132
kgf/cm	1145
mmHG	1157
inH2o	1146

A2 Table Supported Temperature units:

Temperature	
Unit	Code
Kelvin	1000
° Celsius	1001
° Fahrenheit	1002

A3 Table Material codes:

Material	
Description	Code
Carbon Steel	0
Stainless Steel 304	1
Stainless Steel 316	2
Hasteloy C	3
Monel	4
Tantalum	5
Titanium	6
Pt-Ir (Platinum Iridium)	7
Alloy 20	8
PTFE	10
Viton	11
Gold Monel	15
Tefzel	16
Ceramic	18
Stainless Steel 316L	19
PVC	20
Kalrez	22
Inconel	23

A4 Blockscheme transducerblock pressure transmitter

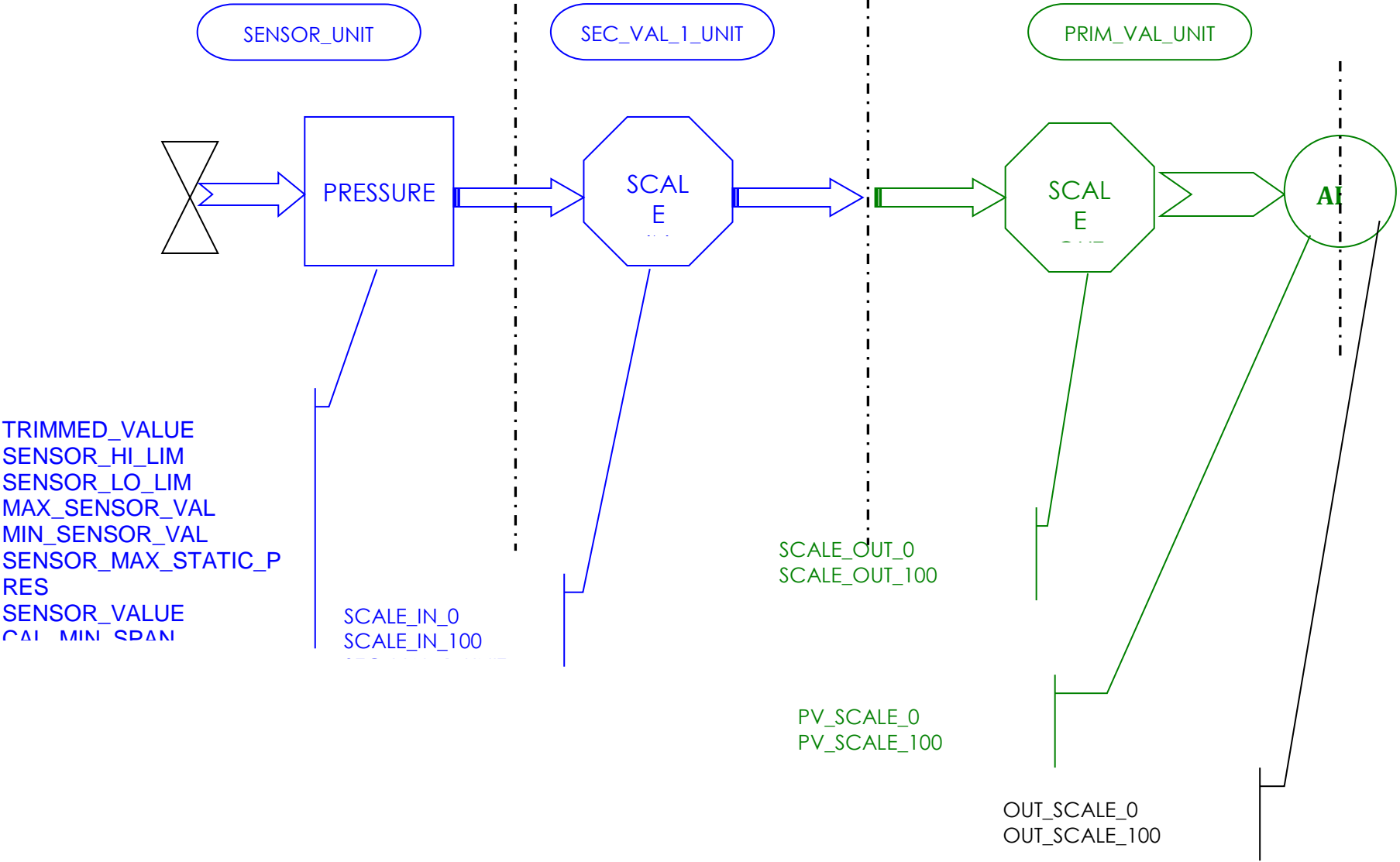

APPENDIX B SERIES2000 PA LEVEL

B1 Table Cal type:

Cal type	
Modus	Code
Dry / Offline(no test pressure)	0
Wet / Online (test pressure)	1
Pressure modus (alleen drukmeting geen linearisaties)	2

B2 Table Supported Sensor units:

Sensor Unit	
Unit	Code
kPa	1133
bar	1137
psi	1141
inHG	1155
mH2O	1521
mmH2O	1149
mbar	1138
atm	1140
MPa	1132
kgf/cm	1145
mmHG	1157
inH2o	1146

B3 Table Supported Level units

Level	
Unit	Code
mH2O	1521
mmH2O	1149
inH2O	1146
mmHG	1157
inHG	1155
cm	1012
mm	1013
feet	1018
inch	1019
yard	1020
percentage	1342

B4. Table Supported Volume units

Volume	
Unit	Code
m ³	1034
l	1038
hl	1041
dm ³	1035
ft ³	1043
us gal	1048
imp gal	1049
inch ³	1042

B5 Table Supported Temperature units:

Temperature	
Unit	Code
Kelvin	1000
° Celsius	1001
° Fahrenheit	1002

B6 Table lin type codes:

Lintype	
Type of linearization	Code
none	0
Table	1
Cil. lying tank	20

B7 Table relation Primary_value cal_type / lin_type

Cal_type	Lin type	Primary Value
0	0	SECONDARY_VALUE_1 (LEVEL)
1	0	SECONDARY_VALUE_1 (LEVEL)
1	1 / 20	VOLUME
2	0 (always 0)	SECONDARY_VALUE_2 (SENSOR_VALUE)

B8 Blockscheme Transducerblock Leveltransmitter

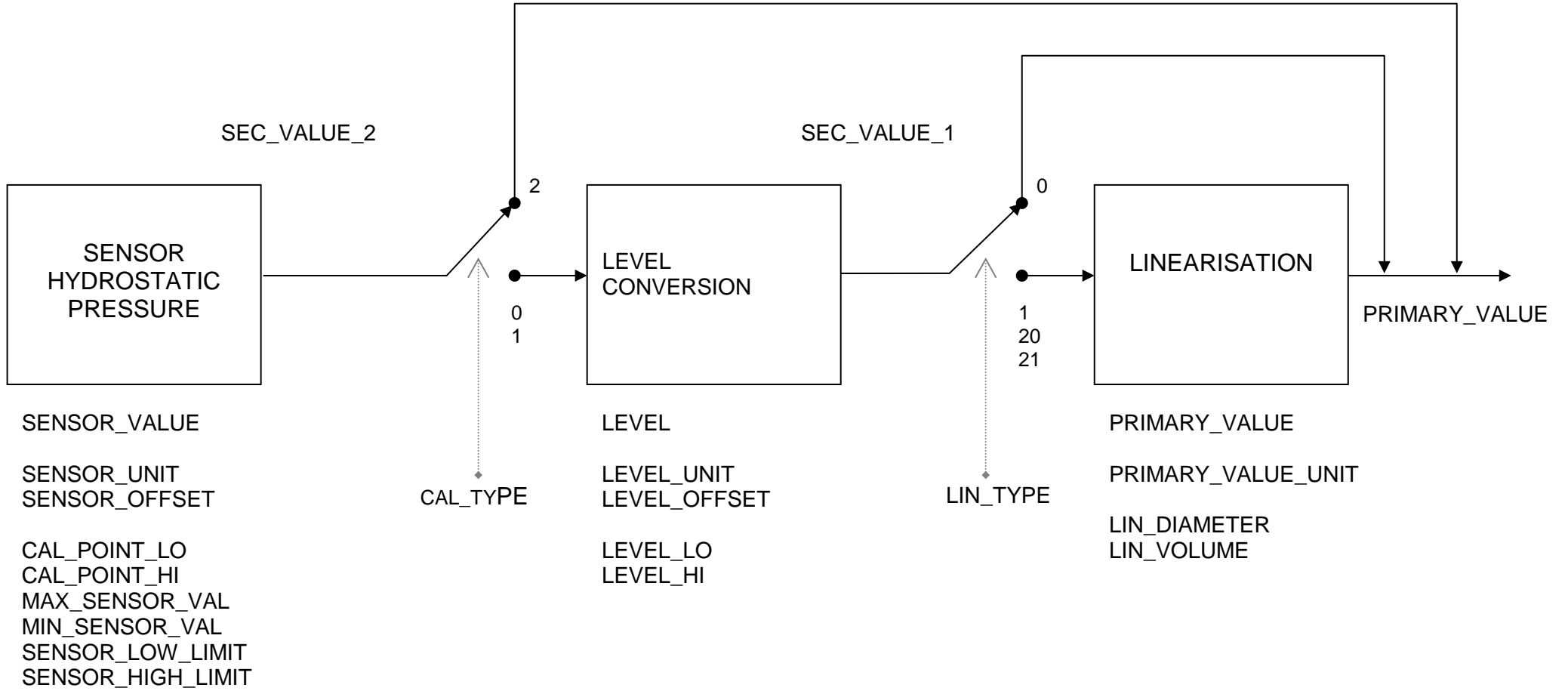

$$SEC_VALUE_2 = SENSOR_VALUE + SENSOR_OFFSET$$

$$SEC_VALUE_1 = LEVEL + LEVEL_OFFSET$$

BIJLAGE C: TANK LINEARISATION (TABLE):

C1 Enter table:

Linearization table	
Step	Action
1	Switch TAB_OP_CODE to 1 (new table) and switch TAB_ENTRY 0. (INDEX = 0)
2	Enter the X- and the Y values for the current index.
3	Increase TAB_ENTRY (index) with 1.
4	Repeat step 2 and 3, until the table is completed.
5	After the table is completed, switch TAB_OP_CODE to 'last value' to close the table. The table is checked for errors.
6	If the table is approved, TAB_STATUS is switched to GOOD and the old table is switched to the new. If the table is not approved, a code is generated and placed in TAB_STATUS (see table for code explanation). The old table is still valid and stays active until the new table is approved.

C2 TAB_OP_CODE:

TAB_OP_CODE	
Code	Description
0	Not initialized
1	New table
3	Last value entered, check table and if approved switch old table for new table.

C3 TAB_STATUS:

TAB_STATUS	
Code	Description
0	Not initialized
1	Table OK (new table is Valid)
2	Not monotonous increasing (old table is valid)
3	Not monotonous decreasing (old table is valid)
4	not enough values transmitted (old table is valid)
5	too many values transmitted (old table is valid)

APPENDIX D Decoding IEEE754 Floating point notation.

The encoding of the IEEE754 floating point notation is as follows:

$$\text{value} = (-1)^S * 2^{(E-127)} * (1 + M^{-1} + M^{-2} + \dots + M^{-n})$$

S = signbit
 E = exponent
 M = mantissa

Example:

OUT has the following value:

Byte #0	Byte #1	Byte #2	Byte #3	Byte #4
0x41	0x20	0x00	0x00	0x80

Byte #4 is the status byte, so it's ruled out.

Byte #0 – Byte #3 are the important bytes in this case.

Bit	#31	#30	#29	#28	#27	#26	#25	#24	#23	#22	#21	#20	#19	#18	#17	#16
	0	1	0	0	0	0	0	1	0	0	1	0	0	0	0	0
	S	E	E	E	E	E	E	E	E	M	M	M	M	M	M	M

Bit	#15	#14	#13	#12	#11	#10	#09	#08	#07	#06	#05	#04	#03	#02	#01	#00
	0	0	0	0	0	0	0	0	0	0	0	0	0	0	0	0
	M	M	M	M	M	M	M	M	M	M	M	M	M	M	M	M

S = 0

E = 10000010_{bin} = 82_{hex} = 130

M = 0100000 00000000 00000000_{bin} = mantissa = 0,25

Value

$$\begin{aligned}
 &= (-1)^S * 2^{(E-127)} * (1 + M) \\
 &= (-1)^0 * 2^{(130-127)} * (1 + 2^{-2}) \\
 &= 1 * 2^3 * (1 + 0,25) \\
 &= 1 * 8 * 1,25 \\
 &= 10.
 \end{aligned}$$



Certificate

Klay Instruments B.V.
 Nijverheidsweg 5; NL-7991 CZ Dwingeloo

the Certificate No.: **Z00635** for the PROFIBUS Slave:

Product Name: Series 2000PA Level
Revision: V3.01; HW: 2; SW/FW: 2
GSD: KLAY0A29.gsd; Profile: PA139700.gsd

This certificate confirms that the product has successfully passed the certification tests with the following scope:

<input checked="" type="checkbox"/>	DP-V0	MS0, Freeze
<input checked="" type="checkbox"/>	DP-V1	MS2
<input checked="" type="checkbox"/>	DP-V2	
<input checked="" type="checkbox"/>	Profile	PA Devices V 3.0
<input checked="" type="checkbox"/>	Physical Layer	MBP

Test Report Number: **PCN074-PAS-01**
 Authorized Test Laboratory: **PROCENTEC, Netherlands**
 Expiry date of Certificate: **May 11, 2009**

The tests were executed in accordance with the following documents:
 "Test Specifications for PROFIBUS PA Devices, Version 4.1 from November 2004".
 This certificate is granted according to the document "Framework for testing and certification of PROFIBUS products".

Karlsruhe, July 21, 2006

 (Official in Charge)



Board of PROFIBUS Nutzerorganisation e. V.

E. Küster _____
 (E. Küster) *Bender* _____
 (Prof. K. Bender)



Certificate

Klay Instruments B.V.
 Nijverheidsweg 5; NL-7991 CZ Dwingeloo

the Certificate No.: **Z00636** for the PROFIBUS Slave:

Product Name: Series 2000PA Pressure
Revision: V3.01; HW: 2; SW/FW: 2
GSD: KLAY0A2A.gsd; Profile: PA139700.gsd

This certificate confirms that the product has successfully passed the certification tests with the following scope:

<input checked="" type="checkbox"/>	DP-V0	MS0, Freeze
<input checked="" type="checkbox"/>	DP-V1	MS2
<input checked="" type="checkbox"/>	DP-V2	
<input checked="" type="checkbox"/>	Profile	PA Devices V 3.0
<input checked="" type="checkbox"/>	Physical Layer	MBP

Test Report Number: **PCN073-PAS-01**
 Authorized Test Laboratory: **PROCENTEC, Netherlands**
 Expiry date of Certificate: **March 26, 2009**

The tests were executed in accordance with the following documents:
 "Test Specifications for PROFIBUS PA Devices, Version 4.1 from November 2004".
 This certificate is granted according to the document "Framework for testing and certification of PROFIBUS products".

Karlsruhe, July 21, 2006

 (Official in Charge)



Board of PROFIBUS Nutzerorganisation e. V.

E. Küster _____
 (E. Küster) *Bender* _____
 (Prof. K. Bender)

- ✓ *Check if the specifications of the transmitter meet the needs of the process conditions*
- ✓ *When the Series 2000-SAN is used as a level transmitter, be aware of the place where the transmitter is mounted. Here are some suggestions:*
 1. *DO NOT mount a level transmitter in- or near filling or discharging pipes.*
 2. *In case of automatic cleaning systems or hand cleaning: never point the water jets on the diaphragm, take necessary steps to avoid this. Guarantee will not be granted.*
- ✓ *When the Series 2000 is used as a pressure transmitter, be aware of the following points:*
 1. *Rapid closing valves in combination with high flow velocity will cause water hammer (spikes) and can destroy the transmitter. DO NOT mount a transmitter near such valves, always a few pipe bends away up or down stream (avoid suction).*
 2. *Install a pressure transmitter a few pipe bends away from pumps, as well on the suction or pressure side of the pump*
- ✓ **WELDING INFORMATION:**
When using the Series 2000 or 2000-SAN code "W" the welding information on page 4 must be followed exactly. This is very important to prevent distortion of the weld-on nipples. It also prevents the screw thread from the Series 2000-SAN (M56 x 1,25) from being deformed.
- ✓ *The diaphragm of the transmitter is protected with a special protection cap. Protect the diaphragm until installation takes place, to prevent damaging of the diaphragm.*
- ✓ *As soon as the wiring is brought inside through the PG9 cable gland and connected to the terminal board, make sure the cable gland is tightly fixed, so that moisture cannot enter into the electronic housing.*
- ✓ *Avoid high-pressure water-jets pointed at the venting.*
- ✓ *If the ambient conditions are very wet, we advise to use a venting through the cable. A special vented cable can be delivered on request. (The normal venting will be removed)*
- ✓ *Turn the covers (1 and 3) hand-tight, so that moisture cannot enter into the electronic housing.*
- ✓ **WARRANTY:** *The warranty is 1 year from delivery date. Klay Instruments B.V. does not accept liability for consequential damage of any kind due to use or misuse of the Series 2000. Warranty will be given, to be decided by the manufacturer. Transmitter must be shipped prepaid to the factory on manufacturers authorization.*
- ✓ **NOTE:** *Klay Instruments B.V. reserves the right to change its specifications at any time, without notice. Klay Instruments B.V. is not an expert in the customers process (technical field) and therefore does not warrant the suitability of its product for the application selected by the customer.*

MANUFACTURER:**KLAY INSTRUMENTS B.V.**

Nijverheidsweg 5 7991 CZ Dwingeloo
P.O. Box 13 7990 AA Dwingeloo The Netherlands

Tel: 0521-591550
Fax: 0521-592046
E-mail: info@klay.nl